

HUMAN
RIGHTS
WATCH

NO MORE EXCUSES

A Roadmap to Justice for CIA Torture



No More Excuses

A Roadmap to Justice for CIA Torture

Copyright © 2015 Human Rights Watch

All rights reserved.

Printed in the United States of America

ISBN: 978-1-62313-2996

Cover design by Rafael Jimenez

Human Rights Watch is dedicated to protecting the human rights of people around the world. We stand with victims and activists to prevent discrimination, to uphold political freedom, to protect people from inhumane conduct in wartime, and to bring offenders to justice. We investigate and expose human rights violations and hold abusers accountable. We challenge governments and those who hold power to end abusive practices and respect international human rights law. We enlist the public and the international community to support the cause of human rights for all.

Human Rights Watch is an international organization with staff in more than 40 countries, and offices in Amsterdam, Beirut, Berlin, Brussels, Chicago, Geneva, Goma, Johannesburg, London, Los Angeles, Moscow, Nairobi, New York, Paris, San Francisco, Tokyo, Toronto, Tunis, Washington DC, and Zurich.

For more information, please visit our website: <http://www.hrw.org>



No More Excuses

A Roadmap to Justice for CIA Torture

Summary	1
Methodology	8
Key Recommendations.....	9
To US Authorities.....	9
To Foreign Governments	9
I. Background	10
Short History of the CIA Program	10
The CIA Program: What Was Known before the Senate Summary.....	19
Justice Department Inquiry into CIA Torture	25
New Details in the Senate Summary.....	29
US Response to the Senate Summary.....	32
II. Bringing Criminal Prosecutions in the US	35
Substance of Potential Charges	35
Torture and Conspiracy to Torture	35
Evidence of Conspiracy to Torture	41
Evidence of Torture: Conduct Beyond What Was Authorized	65
Other Criminal Charges.....	81
Defenses	88
III. Repairing the Harm and Ending Torture.....	96
Obligation to Provide Redress, Compensation, and Rehabilitation	96
US Failure to Comply with International Legal Obligations	98
Legislation, Other Measures	104
IV. International Accountability Mechanisms	111
Investigations and Prosecutions of US Officials.....	117
Investigations Focused on European Complicity.....	137

Potential Investigation by the International Criminal Court	144
Recommendations	147
To the US President	147
To the Department of Justice	148
To the US Congress	148
To Countries that Provided Support to the CIA Rendition Program	148
To All Foreign Governments.....	149
To Specific National Authorities in the Following Countries.....	149
To the European Parliament, the Parliamentary Assembly of the Council of Europe, and UN Experts and Bodies.....	151
To the Office of the Prosecutor of the International Criminal Court	151
Acknowledgments	152

Summary

It is now well established that following the attacks on the United States on September 11, 2001, the US Central Intelligence Agency (CIA) operated a global, state-sanctioned program in which it abducted scores of people throughout the world, held them in secret detention—sometimes for years—or “rendered” them to various countries, and tortured or otherwise ill-treated them. While the program officially ended in 2009, the cover-up of these crimes appears to be ongoing.

Many detainees were held by the CIA in pitch-dark windowless cells, chained to walls, naked or diapered, for weeks or months at a time. The CIA forced them into painful stress positions that made it impossible for them to lie down or sleep for days, to the point where many hallucinated or begged to be killed to end their misery. It used “waterboarding” and similar techniques to cause near suffocation or drowning, crammed detainees naked into tiny boxes, and prevented them from bathing, using toilets, or cutting their hair or nails for months. “We looked like monsters,” one detainee said of his appearance while in CIA custody.

Much new information about detention and interrogation in the CIA program became public with the release in redacted form of the 499-page summary of the Senate Select Committee on Intelligence report in December 2014 (“Senate Summary”). The Senate Summary reported that the CIA subjected at least five detainees to “rectal feeding,” described in one case as infusing the pureed contents of a lunch tray into the detainee’s rectum via a medical tube, done “without evidence of medical necessity.” The Senate Summary also found that during a waterboarding session, one detainee became “completely unresponsive, with bubbles rising through his open, full mouth.” The CIA forced some detainees to stand for days on end without sleep while they had broken bones in their legs and feet, even though CIA personnel knew this would cause them long-term physical injury. A CIA cable described one detainee as “clearly a broken man” and “on the verge of complete breakdown.”

The US government has not adequately accounted for these abuses. It has an obligation under international law to prosecute torture where warranted and provide redress to victims, but it has done neither. No one with real responsibility for these crimes has been

held accountable and the government has actively thwarted attempts on the part of victims to obtain redress and compensation in US courts.

The Obama administration asserted that it conducted a criminal investigation of the CIA program through a Department of Justice inquiry led by a career prosecutor, Assistant US Attorney John Durham. The Durham investigation closed on August 30, 2012 without bringing any criminal charges. The apparent failure of the investigation to question current or former detainees undercuts any claims that it was thorough or credible.

As set out in this report, Human Rights Watch concludes there is substantial evidence to support the opening of new investigations into allegations of criminal offenses by numerous US officials and agents in connection with the CIA program. These include torture, assault, sexual abuse, war crimes, and conspiracy to commit such crimes. In reaching this conclusion, we have drawn on our own investigations, media and other public reports, and the declassified information in the Senate Summary. But more evidence exists that has yet to be made public.

We believe that an independent and impartial investigation that has access to the full Senate report, other information that the government continues to keep classified, and interviews with current and former detainees, would yield further evidence of crimes and identify more suspects than we do here.

US officials who created, authorized, and implemented the CIA program should be among those investigated for conspiracy to torture as well as other crimes. They include: Acting CIA General Counsel John Rizzo, Assistant Attorney General for Office of Legal Counsel (OLC) Jay Bybee, OLC Deputy Assistant Attorney General John Yoo, an individual identified as “CTC Legal” in the Senate Summary, CIA Director George Tenet, National Security Legal Advisor John Bellinger, Attorney General John Ashcroft, White House Counsel Legal Advisor Alberto Gonzales, Counsel to the Vice President David Addington, Deputy White House Counsel Timothy Flanigan, National Security Advisor Condoleezza Rice, Defense Department General Counsel William Haynes II, Vice President Dick Cheney, and President George W. Bush. In addition, James Mitchell and Bruce Jessen, CIA psychologist contractors who devised the program, proposed it to the CIA, and helped carry it out, should also be investigated for their role in the initial conspiracy.

We believe there is also sufficient evidence to investigate others who were not necessarily part of the initial conspiracy but who later joined it. Individuals can join an already existing conspiracy if they are aware of the conspiracy's unlawful aims, in this case torture, and take steps intended to help the conspiracy succeed. These would include those who reauthorized the program after the legal memos endorsing it—the “Torture Memos”— were withdrawn, those who supplied false information to the Justice Department upon which the Justice Department relied in providing reauthorization, and those who later oversaw operation of the CIA program.

Others should not only be investigated for torture but also for offenses such as war crimes, assault, and sexual abuse. Even if individuals who carried out the torture can be said to have reasonably relied in good faith upon OLC memos or CIA guidance to justify their conduct—which, as detailed below, there is serious reason to doubt—considerable evidence exists that CIA officers and interrogators tortured detainees in ways that went beyond what was authorized.

This report also considers and rebuts arguments that barriers to prosecution under US law—such as statutes of limitation, certain defenses, or a “specific intent” requirement—might make it impossible to pursue criminal cases.

The failure to credibly investigate and prosecute torture committed in any territory under US jurisdiction violates US obligations under the Convention against Torture and Other Cruel, Inhuman or Degrading Treatment or Punishment and other treaties to which the US is a party. Other countries and entities should open their own investigations into CIA torture and should exercise universal jurisdiction, where applicable, over US nationals and others implicated in torture or other abuses. Additionally, countries that were complicit or otherwise unlawfully assisted the CIA program should also conduct investigations into the alleged illegal conduct of their own nationals.

Besides violating international law, the US government's inaction in the face of clear evidence of torture sends a message to future US policymakers and officials that they too can commit torture and other ill-treatment and not fear being held accountable. Several presidential candidates for the 2016 elections have already indicated they would consider using so-called “enhanced interrogation techniques” if they were to be elected.

Holding government officials accountable for serious abuses is never easy; when high-level officials are involved, it can be politically divisive. But Human Rights Watch research over the past 25 years in dozens of countries has shown that forgoing criminal accountability carries a high price. (See particularly Human Rights Watch, *Selling Justice Short* (2009)). Lack of accountability may fuel future abuses and weaken the rule of law.

Globally, the US unwillingness to prosecute CIA torture weakens US authority to oppose torture and other abuses abroad, provides a ready excuse for countries unwilling to prevent or prosecute torture in their own countries, and undermines global respect for the rule of law.

The egregious abuse of prisoners in CIA custody and failure to hold anyone accountable has undermined global efforts to fight terrorism. Detainee abuse, including abuse of prisoners by the US military, has been used by terrorist groups to obtain new recruits and contributed to anti-US sentiment in many countries.

Ultimately, the guilt or innocence of any of the US officials involved in organizing or carrying out the CIA program will rest with the criminal justice system. Suspects should be tried in criminal proceedings that comport with international due process and fair trial standards, including allowing them to challenge evidence, present defenses, and raise mitigating circumstances. But before these fundamental institutions of democratic rule can even be set in motion, US criminal justice officials need to first conduct credible investigations and bring charges where appropriate, requirements that have gone unmet for well over a decade since the first revelations of CIA torture after 9/11.

This report is organized into three parts—credible investigations and prosecutions, redress, and international justice—reflecting different steps the US and other countries should take to pursue accountability for CIA program abuses.

Credible Investigations and Prosecutions: The first part of this report examines some of the specific federal criminal charges that could be brought against US officials involved the CIA program. The most senior responsible officials should not be able to avoid culpability on the grounds that they relied on advice from White House lawyers stating that the interrogation techniques used on detainees did not amount to torture. This defense is weak not only because the legal reasoning was so poor that it was soon repudiated by other Bush

administration lawyers and virtually all other legal professionals, but also because, in this case, those involved in the CIA program themselves helped create the legal advice being used as a shield to protect them from accountability for their alleged crimes.

Officials in the CIA and at the White House should have known, from the moment the techniques in question were proposed, that they were violating the federal Torture Statute: the techniques were reverse-engineered from a program designed to train US special forces to endure torture, some were explicitly designated as torture by US courts, and many were banned in the US Army Field Manual for Intelligence Interrogations in effect at the time the abuse was approved.

And there is evidence in the Senate Summary that officials actually knew that the techniques violated the Torture Statute. According to a Department of Justice Office of Professional Responsibility investigation (OPR investigation), the CIA, through its acting General Counsel John Rizzo, expressed concern about “criminal liability” under the Torture Statute and sought, but failed to obtain, a guarantee from the Justice Department’s Criminal Division that employees would not be prosecuted for use of the techniques.

The Senate Summary also contains a reference to a draft letter to the attorney general from “CTC Legal” —a likely reference to someone in the legal department of the CIA’s counterterrorism center—acknowledging that the “aggressive methods” of interrogation the CIA was planning would violate the Torture Statute. While there are no records showing that the letter was sent, its existence shows that at least some CIA advisers believed from the beginning that the techniques being proposed were illegal. Finally, the OPR investigation also noted that in mid-2002 senior White House and CIA officials appear to have been involved in shaping the contents of the soon-to-be issued legal memos authorizing abusive interrogation techniques, with sections likely added at their request after the Justice Department refusal to give a non-prosecution guarantee.

Viewed in this context, there is strong reason to conclude that the infamous and since discredited “Torture Memos” issued by the OLC in August 2002 authorizing techniques that many others had previously determined to be torture, should be viewed as little more than a legal fig leaf. “The position taken by the government lawyers in these legal memoranda amount to counseling a client as to how to get away with violating the law,”

said John Gibbons, former chief judge of the US Court of Appeals for the Third Circuit, after the memos had been released.

Other White House and CIA officials and OLC lawyers later joined the conspiracy by knowingly keeping in the dark government officials they knew would oppose the CIA program, allowing the conduct to continue despite knowledge detainees were being mistreated, and reauthorizing the program once original authorizations were revoked after news of torture by the US military at the Abu Ghraib prison in Iraq became public.

CIA personnel also engaged in practices that went well beyond the illegal techniques “authorized” by the Torture Memos. Practices such as “rectal feedings,” use of water to induce near suffocation, and certain painful stress positions, were either not authorized or administered in ways that were not authorized. As such, the memos should not even be contemplated as a defense for such actions.

Lastly, while the five-year federal statute of limitations for most federal crimes might be thought to present an insurmountable bar to prosecution, it should not apply to many of the crimes committed as part of the CIA program. It is not a bar to prosecutions for torture or conspiracy to torture when there is a “foreseeable risk that death or serious bodily injury” may result, or to prosecutions for the types of sexual abuse allegedly committed by CIA program personnel. For all federal conspiracy charges, moreover, the statute of limitations can be extended if perpetrators conceal a central component of the conspiracy, as seems to have been the case here.

Redress: The second part of this report looks at the US government’s obligation to provide redress to victims of abuse, including compensation and rehabilitation services, guarantees of non-repetition (including through legislation and public statements), and public disclosure of relevant information. The Convention against Torture and other treaties require the US to provide redress for torture and other serious abuses, including arbitrary detention and enforced disappearance. Not only has the US failed to provide compensation or any other form of redress to detainees in CIA custody, the Obama administration has blocked every attempt by former detainees to bring civil suits in US courts by invoking doctrines of state secrecy, state immunity, and national security.

International Justice: The third part of this report looks at the efforts of other governments to investigate CIA torture and related abuses that occurred in their countries.

Investigations in other countries have targeted US officials as well as national officials alleged to have participated in or been complicit in CIA abuses.

The duty to prosecute serious violations of international law lies primarily with domestic judicial authorities in the country with principal jurisdiction over the crime. This normally requires having a territorial link to the crime or the persons involved. However, third countries can also investigate and prosecute on the basis of universal jurisdiction—laws embodying the idea that certain crimes, including torture and war crimes, are so egregious that every state has an interest in bringing perpetrators to justice.

The Convention against Torture contains a universal jurisdiction clause that places an affirmative duty on governments to prosecute suspects who come on their territory regardless of where the torture took place. The Geneva Conventions of 1949 relating to war crimes contains similar provisions. The US government’s failure to conduct its own thorough and credible investigations into allegations of torture increases the importance of states exercising universal jurisdiction for crimes alleged to have been carried out as part of the CIA program.

Although the United States is not a party to the International Criminal Court (ICC), the ICC may also be an avenue to accountability for alleged abuses by US nationals in Afghanistan. The ICC is conducting a preliminary examination of the situation in Afghanistan, which includes alleged torture of detainees by US armed forces there. Whether the preliminary examination will lead to a formal investigation was not known as this writing.

Methodology

The report was assembled using the numerous public source materials that now exist documenting CIA renditions, detentions, torture and other ill-treatment. This includes our own Human Rights Watch reporting and the declassified information in the Senate Summary, but also books, media, and other public reports, both by governmental and non-governmental organizations. It is also informed by nearly 15 years of our own research, reporting and analysis on US counterterrorism abuses post 9/11.

We took this extensive factual record and supplemented it with legal research into the various charges that could be brought for certain offenses under US law. In doing so we focused on the main charges that would be available for the conduct in question and did not include other charges such as obstruction of justice or false reporting that do not center on the actual conduct in question. We also tried to include the most viable charges and intentionally excluded those for which we thought a case might be made but for which it was not clear whether there was sufficient evidence to support. We also supplemented the factual record with legal research into civil remedies and international law.

Key Recommendations

To US Authorities

- The Attorney General, with the support of the president, should appoint a special prosecutor to conduct a thorough, independent, and credible criminal investigation into the CIA torture that examines all evidence, including statements from current and former detainees.
- The president should acknowledge wrongdoing, apologize to victims of torture, and devise policies ensuring that victims receive appropriate redress, compensation, and rehabilitation services.
- The president should declassify the full Senate Intelligence Committee Report on the CIA rendition, detention, and interrogation program, redacting only what is strictly necessary to protect national security, to ensure there is a full public accounting of government wrongdoing and that victims of torture can obtain redress.

To Foreign Governments

- Governments that provided support to the CIA program should ensure impartial and independent criminal investigations of complicity in torture and other criminal offenses allegedly committed in their countries by national and US officials in connection with CIA renditions or interrogations, and prosecute those implicated in crimes. Unless and until US officials show a willingness to pursue meaningful accountability for CIA torture, other governments should exercise universal jurisdiction or other forms of jurisdiction provided under international and domestic law to investigate and, evidence permitting, prosecute US officials for their alleged role in torture and other abuses.

I. Background

Short History of the CIA Program

The September 11, 2001 attacks on the United States took the lives of nearly 3,000 people and had an impact that reverberated, and still reverberates, around the globe. Following those attacks, President George W. Bush publicly sought and soon obtained from Congress the authority to use force against those responsible for the attacks and those assisting them.

Six days after the attacks, on September 17, Bush secretly issued what is known as a Memorandum of Notification (MON)—a covert action directive that granted the CIA unprecedented counterterrorism authority, including to capture and detain individuals "posing a continuing, serious threat of violence or death to U.S. persons and interests or planning terrorist activities."¹ The MON made no reference to interrogations or coercive interrogation techniques.

The CIA immediately began developing a plan to detain individuals under the MON. Senior agency leadership acknowledged that the CIA had limited experience running detention facilities and considered acquiring expertise from the Defense Department and the Federal Bureau of Prisons.² In late March 2002 the CIA captured Abu Zubaydah, who became its first detainee.³ Plans then intensified to establish the use of certain aggressive interrogation techniques. Arguments ensued between the Federal Bureau of Investigation (FBI) and the CIA over the types of interrogation techniques that should be used.⁴ The FBI wanted to use methods that they had developed for years that did not involve violence or force. FBI agents and officers involved in these discussions said the aggressive techniques

¹ US Senate, Select Committee on Intelligence, Committee Study of the Central Intelligence Agency's Detention and Interrogation Program, December 13, 2012, updated April 3, 2014, released December 2, 2014, http://fas.org/irp/congress/2014_rpt/ssci-rdi.pdf (accessed February 18, 2015) (hereinafter "Senate Summary"), p. 11.

² Senate Summary, p. 12.

³ Senate Summary, p. 22.

⁴ Senate Summary, p. 27. For a more in-depth discussion of this dispute, see generally, Ali Soufan, *The Black Banner: The Inside Story of 9/11 and the War Against al-Qaeda*, (New York: W.W. Norton & Co. 2011); see also Department of Justice, Oversight and Review Division, Office of Inspector General, "A Review of the FBI's Involvement in and Observations of Detainee Interrogations in Guantanamo Bay, Afghanistan, and Iraq," May, 2008, <https://oig.justice.gov/special/so805/final.pdf> (accessed October 12, 2015) (hereinafter "DOJ OIG Report"), pp. 71-75.

the CIA sought to use were not only ineffectual, but would taint any evidence they acquired for use in criminal trials.⁵

The CIA proposed the use of 12 interrogation techniques.⁶ The techniques, proposed by two CIA contractors, had previously been used by the military's Joint Personnel Recovery Agency (JPRA) to train US Special Forces to better endure interrogation methods used by enemies who did not abide by the Geneva Conventions.⁷

The 12 “enhanced interrogation techniques” proposed were: (1) the attention grasp; (2) “walling”; (3) facial hold; (4) facial slap; (5) cramped confinement; (6) wall standing; (7) stress positions; (8) sleep deprivation; (9) waterboarding; (10) use of diapers; (11) use of insects; and (12) mock burial.⁸ When it was clear that the CIA was going to use such

⁵ US Department of Justice, Office of Professional Responsibility, “Investigation into the Office of Legal Counsel's Memoranda Concerning Issues Relating to the Central Intelligence Agency's Use of ‘Enhanced Interrogation Techniques’ on Suspected Terrorists,” July 29, 2009, https://www.aclu.org/files/pdfs/natsec/opr20100219/20090729_OPR_Final_Report_with_20100719_declassifications.pdf (accessed October 12, 2015) p. 33; see also DOJ OIG Report, pp. 71-72.

⁶ Senate Summary, p. 32.

⁷ Human Rights Watch, *Getting Away with Torture: The Bush Administration and Mistreatment of Detainees*, July 12, 2011, http://www.hrw.org/sites/default/files/reports/uso711webwcover_1.pdf, p. 40, citing US Senate, Committee of Armed Services, “Report on Inquiry into the Treatment of Detainees in US Custody,” November 20, 2008, http://www.armed-services.senate.gov/imo/media/doc/Detainee-Report-Final_April-22-2009.pdf (accessed October 12, 2015) (hereinafter “SASC Report”), p. 6.

⁸ Senate Summary, p. 32. All of these “techniques,” with the exception of “diapers” and “mock burial” were eventually approved in an August 1, 2002 memo (though cramped confinement and insects were combined into one and discussed together). In that August 1, 2002, memo each of the “techniques” were approved for use specifically on Abu Zubaydah and were described in the following manner: 1) “attention grasp”: grabbing the individual with both hands by the collar in a controlled and quick motion and drawing him to the interrogator; 2) “walling”: with his heels touching the wall the subject is “pulled forward and then quickly and firmly push[ed]” into a flexible false wall so that his shoulder blades hit the wall. His head and neck are supported with a rolled towel to prevent whiplash; 3) “facial hold”: an interrogator places his open palms on both sides of the individual's face to keep his head immobile; 4) “facial slap”: the interrogator slaps an individual's face; the goal is not to inflict physical pain but “to induce shock, surprise and/or humiliation;” 5) “cramped confinement:” the individual is placed in a confined space, usually dark. In the larger box the detainee could stand, but in the smaller one, he could only sit. For Abu Zubaydah, who had a fear of insects, interrogators requested permission to put a small non-stinging insect into his box and to tell Abu Zubaydah, falsely that it could sting. This was approved; 6) “wall standing”: a detainee is forced to stand about four to five feet from a wall, touching the wall so that his fingers supported all of his body weight, and he was not permitted to move or reposition his hands or feet. The intent was to induce muscle fatigue. No time limit appears to have been placed on this technique; 7) “stress positions”: the memo states that “a variety of stress positions” may be used but only two were described in any detail. One involved forcing Abu Zubaydah to sit on the floor with his legs extended straight out in front of him with his arms raised above his head. Another proposed having him kneel on the floor while leaning back at a 45 degree angle. The intention was to produce muscle fatigue. No specific time limit appears to have been imposed for this technique either; 8) “sleep deprivation”: up to 11 days were approved for use on Abu Zubaydah; 9) “waterboard”: an individual is bound securely to an inclined bench. The individual's feet are elevated. A cloth is placed over the forehead and eyes. Water is then applied to the cloth in a controlled manner. As this is done the cloth is lowered until it covers both the nose and mouth. Once the cloth is saturated and completely covers the mouth and nose, air flow is slightly restricted for 20 to 40 seconds due to the presence of the cloth. The resulting increased carbon dioxide level in the blood stimulates an increased effort to breathe, producing the perception of “suffocation and incipient panic, i.e. the perception of

methods, the FBI refused to participate in any further interrogations using “enhanced interrogation techniques” or participate in any further discussions about the matter.⁹

As detailed below, the decision to use these techniques was discussed extensively among senior US officials, including but not limited to: CIA General Counsel John Rizzo, Assistant Attorney General and OLC head Jay Bybee, OLC Deputy Assistant Attorney General John Yoo, an unnamed individual identified as “CTC Legal” in the Senate Summary, CIA Director George Tenet, National Security Legal Advisor John Bellinger, Attorney General John Ashcroft, White House Counsel Alberto Gonzales, Counsel to the Vice President David Addington, Deputy White House Counsel Timothy Flanigan, and National Security Advisor Condoleezza Rice.

Before the CIA used the full panoply of these techniques on Abu Zubaydah, the agency sought a guarantee that the Justice Department Criminal Division would not prosecute any US personnel involved.¹⁰ The Criminal Division refused.¹¹ Following this, the CIA began working intensely with the attorneys in the OLC to obtain memos that would authorize the techniques proposed. (Meetings and deliberations about the content of the memos are discussed in detail below.) Two memos were eventually issued on August 1, 2002. The principal author of the memos was Yoo and they were signed by Assistant Attorney General Jay Bybee.¹²

The first memo was addressed to Gonzales and became known as the “Bybee I Memo.” It was unclassified and analyzed the domestic and international legal prohibitions on torture and, among other things, articulated an exceedingly high threshold, later repudiated by the Bush administration, for what constitutes torture: physical pain equivalent in intensity to that accompanying “organ failure, impairment of bodily function, or even death.”¹³ It did

drowning.” During the 20-40 seconds, water is continuously poured from above. After this period the cloth is lifted and the individual is allowed to breathe three to four full breaths. The procedure may then be repeated. The procedure would likely not last more than 20 minutes during any one application. “Memorandum from Jay S. Bybee, assistant attorney general, to John Rizzo, acting general counsel of the CIA, regarding ‘Interrogation of al Qaeda Operative,’” August 1, 2001, <http://www.justice.gov/sites/default/files/olc/legacy/2010/08/05/memo-bybee2002.pdf> (accessed March 31, 2015) (“Bybee II Memo.”).

⁹ OPR Report, p. 47; see also DOJ OIG Report, pp. 71-75.

¹⁰ OPR Report, p. 47.

¹¹ Ibid.

¹² OPR Report, pp. 75-80, 251, 255.

¹³ “Memorandum from Jay S. Bybee, assistant attorney general, to Alberto R. Gonzales, counsel to the president, regarding “Standards for Conduct of Interrogation under 18 U.S.C. Sections 2340-2340A,” August 1, 2002,

not discuss the legality of any particular technique nor the legality of applying any type of technique on a specific detainee. It was not made public until it was leaked to the media in June 2004.¹⁴

The second memo, which was classified, was addressed to John Rizzo but also signed by Bybee, became known as the “Bybee II Memo.” It was not released publicly until 2009 and discussed the legality of each of the techniques individually, approving 10 specific interrogation tactics proposed for use on detainee Abu Zubaydah.¹⁵ (“Diapering” and the “mock burial,” though initially proposed, were not discussed in the memo). These two memos collectively have publicly become known as the “Bybee Memos,” the “August 1, 2002 OLC Memos,” or the “Torture Memos.”¹⁶

After these memos were issued, the CIA began using what they called “enhanced interrogation techniques” with little guidance. The CIA now admits that its guidance was poor during this period.¹⁷ At some point after “enhanced interrogation techniques” and detentions were contemplated, the CIA began opening and operating a number of secret detention centers around the world. The US government has still not disclosed exactly where and how many sites it operated. Though a number of CIA sites are identified in the Senate Summary, they are designated using pseudonyms for their locations. But the media and others have long reported that the CIA operated detention centers in at least Afghanistan, Lithuania, Poland, Romania, and Thailand.¹⁸ Additionally, the CIA worked in

<http://www.justice.gov/sites/default/files/olc/legacy/2010/08/05/memo-gonzales-aug2002.pdf> (accessed March 31, 2015) (“Bybee I Memo”).

¹⁴ Dana Priest, “Justice Dept. Memo Says Torture ‘May Be Justified,’” *Washington Post*, June 13, 2004, <http://www.washingtonpost.com/wp-dyn/articles/A38894-2004Jun13.html> (accessed August 18, 2015).

¹⁵ See Bybee II Memo, described in note 8 above.

¹⁶ One former CIA official later called these opinions a “golden shield,” and said that they that provided enormous comfort. See Jack Goldsmith, *The Terror Presidency: Law and Judgment Inside the Bush Administration*, (New York: W. W. North & Co: 2009), p. 144; see also SASC Report, p. 33.

¹⁷ CIA, “Comments on the Senate Select Committee on Intelligence’s Study of the Central Intelligence Agency’s Former Detention and Interrogation Program,” https://www.cia.gov/library/reports/CIAs_June2013_Response_to_the_SSCI_Study_on_the_Former_Detention_and_Interrogation_Program.pdf (accessed October 12, 2015) (hereinafter “CIA Response”), pp. 2-4.

¹⁸ Adam Goldman and Julie Tate, “Decoding the secret black sites on the Senate’s report on the CIA interrogation program,” *Washington Post*, December 9, 2014, <https://www.washingtonpost.com/news/worldviews/wp/2014/12/09/decoding-the-secret-black-sites-on-the-senates-report-on-the-cia-interrogation-program/> (accessed August 26, 2015); see also Human Rights Watch, “Statement on US Secret Detention Facilities in Europe,”

Human Rights Watch statement, November 6, 2005, <https://www.hrw.org/news/2005/11/06/human-rights-watch-statement-us-secret-detention-facilities-europe>.

conjunction with a number of other countries to operate, run or use detention sites in locations that included but were not limited to Morocco,¹⁹ Jordan,²⁰ Pakistan,²¹ and Egypt.²²

During the course of the CIA program, the agency held at least 119 individuals in CIA-run detention centers, according to the Senate Summary. This is a conservative estimate²³ and does not include a number of detainees who were unlawfully rendered as part of the CIA program.²⁴

The full name for the CIA Program was the “Rendition, Detention and Interrogation” (RDI) program. Unlawful renditions were a part of the program but the Senate Summary did not address this aspect of it.²⁵ The summary lists only the names of 119 individuals it considers to be “detainees” in that there was “clear evidence of detention in CIA custody.”²⁶ Left off the list are an unknown number of individuals whom the CIA unlawfully rendered to countries where it was known or recognized as likely that they would be tortured, whether as part of

¹⁹ Human Rights Watch, *Delivered Into Enemy Hands: US-Led Abuse and Rendition Opponents to Gaddafi's Libya*, September 2012, http://www.hrw.org/sites/default/files/reports/libya0912webwcover_1.pdf, p. 78; Matt Apuzzo, Adam Goldman, “CIA Whisked Detainees From Guantanamo Before Giving Access To Lawyers,” *Huffington Post*, May 25, 2011, http://www.huffingtonpost.com/2010/08/06/cia-whisked-detainees-fro_n_673001.html (accessed August 26, 2015); Mathew Cole, “Lithuanian President Announces Investigation into CIA Secret Prison,” *ABC News*, October 21, 2009, <http://abcnews.go.com/Blotter/lithuania-investigating-secret-cia-prisons/story?id=8874887> (accessed August 26, 2015).

²⁰ Craig Whitlock, “Jordan’s Spy Agency: Holding Cell for the CIA,” *Washington Post*, <http://www.washingtonpost.com/wp-dyn/content/article/2007/11/30/AR2007113002484.html> (accessed August 26, 2015).

²¹ *Delivered Into Enemy Hands*, pp. 34-38, 61-62, 84-85.

²² “Libya/US: Investigate Death of Former CIA Prisoner,” Human Rights Watch news release, May 11, 2009, <https://www.hrw.org/news/2009/05/11/libya/us-investigate-death-former-cia-prisoner>.

²³ Senate Summary, p. 14, n. 26.

²⁴ Unlawful renditions are not a focus of this report but have been extensively documented in prior reports, including *Delivered Into Enemy Hands*; Human Rights Watch, *Getting Away with Torture: The Bush Administration and Mistreatment of Detainees*, July 12, 2011, http://www.hrw.org/sites/default/files/reports/uso711webwcover_1.pdf. Other organizations have extensively documented CIA renditions as well. See e.g. Open Society Justice Initiative (OSJI), “Globalizing Torture: CIA Secret Detention and Extraordinary Rendition,” February 2013, <http://www.opensocietyfoundations.org/sites/default/files/globalizing-torture-20120205.pdf> (accessed June 4, 2015) (hereinafter “OSJI, “Globalizing Torture: CIA Secret Detention and Extraordinary Rendition”); The Constitution Project, *The Report of The Constitution Project's Task Force on Detainee Treatment* (hereinafter “The Constitution Project Report”) April 2013, <http://detainee-taskforce.org/pdf/Full-Report.pdf> (accessed August 25, 2015), p. 127. The CIA carried out numerous renditions that were unlawful and in violation of the Convention against Torture and other treaties to which the US is party. The US has an obligation to fairly prosecute those officials responsible for unlawful renditions. Several civil cases involving CIA rendition are discussed in the second chapter of this report “Bringing Criminal Prosecutions in the US.”

²⁵ Rendition is the transfer of an individual between governments. Transferring someone to another country without providing them an adequate opportunity to contest that transfer violates basic rights under international human rights law. Transferring someone to another government where they would face a serious risk of torture or other ill-treatment is also prohibited under international law. Transferring an individual to the custody of another government for the purpose of torture, usually to obtain information, is a practice commonly referred to as rendition to torture. The phrase “extraordinary rendition” has come to mean unlawful rendition. *Delivered Into Enemy Hands*, p. 1, n. 2.

²⁶ Senate Summary, p. 14, n. 26.

their interrogation or as punishment.²⁷ Many of those rendered described being held by the CIA or by another government with the CIA's cooperation, either before or after their transfer.²⁸

Of the 119 individuals the CIA considers to have been CIA "detainees," according to the Senate Summary, at least 26 were "wrongfully held," and did not meet the CIA's own standards for detention.²⁹ "CIA records provide insufficient information to justify the detention of many other detainees."³⁰

In November 2002, detainee Gul Rahman died from hypothermia after being shackled half-naked to a concrete floor overnight in CIA custody at a detention site in Afghanistan.³¹ His death spurred an investigation by the CIA Office of the Inspector General (OIG), including into the broader CIA program. The findings, issued in classified form in a May 2004 report ("CIA OIG Report"), were sharply critical of the both the CIA's use of techniques in an authorized manner, and the use of techniques not authorized.³²

While the OIG investigation was ongoing, media outlets began reporting that the US was using abusive interrogation methods on detainees in secret detention centers.³³ To counter these reports, the Bush administration began putting out a number of statements aimed at alleviating concerns that the US might be abusing or torturing prisoners. These statements attempted to discount any possibility that the US was using torture and to emphasize that all detainees were being treated humanely even if they were not, in the administration's view, protected by international law.³⁴

²⁷ See *Getting Away with Torture*, discussing the cases of Maher Arar, Mamdough Habib, Ahmed Agiza and Mohammed al-Zari, Osama Moustafa Nasr (Abu Omar), Muhammad Haydar Zammar, and Muhammad Saad Iqbal Madni, pp. 33-38; See also *Delivered Into Enemy Hands*, discussing the cases of Abdul Hakim Belhadj, Sami Mostefa al-Saadi, and Mustafa Salim Ali el-Madaghi, *Delivered into Enemy Hands*, pp. 78, 91 and 102. See also generally, OSJI, "Globalizing Torture: CIA Secret Detention and Extraordinary Rendition."

²⁸ Ibid.

²⁹ Senate Summary, pp. 14-17; see also "Senate Select Committee on Intelligence, Committee's Study of the CIA's Detention and Interrogation Program, Findings and Conclusions,"

http://www.feinstein.senate.gov/public/index.cfm/files/serve?File_id=a992171e-fd27-47bb-8917-5eb98c72764&SK=04753BC866283CoF5913D7E1A24FA851 (accessed October 12, 2015) (hereinafter "Senate Summary Findings and Conclusions"), p. 12.

³⁰ Senate Summary Findings and Conclusions, p. 12.

³¹ Senate Summary, p. 54.

³² See General OIG report. See also Levin and Bradbury Memos.

³³ Dana Priest and Barton Gellman, "U.S. Decries Abuse but Defends Interrogations," *Washington Post*, December 26, 2002, <http://www.washingtonpost.com/wp-dyn/content/article/2006/06/09/AR2006060901356.html> (accessed August 21, 2015).

³⁴ Senate Summary pp. 115-119; David Cole, "Torture: No One Said No," *New York Review of Books*, March 5, 2015, <http://www.nybooks.com/blogs/nyrblog/2015/mar/05/cia-torture-no-one-said-no/> (March 15, 2015).

These statements caused concern among the CIA leadership that other parts of the executive branch were not backing the CIA's program. The CIA began to seek assurances from Secretary of State Rice, the OLC, and other executive branch departments that they continued to support the CIA program. This generated another series of high-level meetings during which the CIA secured reassurance that the White House and the Justice Department backed the program.³⁵

After the CIA OIG Report was issued, CIA Director Tenet suspended both the use of what were called "standard" interrogation techniques, as well as "enhanced interrogation techniques," pending a legal and policy review.³⁶ The CIA OIG Report also called for the CIA to justify the usefulness and necessity of the "enhanced interrogation" program.

Even before the OLC and the CIA approved the use of "enhanced interrogation techniques," the US military had already begun using some of the tactics later authorized in the August 1, 2002 OLC Memos and had trained military interrogators in their use. Formal OLC and CIA approval set the stage for more widespread use of abusive techniques by the military.³⁷

In March 2004, reports and photographs emerged about detainee abuse by US military personnel at Abu Ghraib prison in Iraq causing a national scandal.³⁸ And in June 2004, the Bybee I Memo was leaked to the media.³⁹ By this time Yoo had left OLC, and Jack Goldsmith was named to replace him.⁴⁰

³⁵ Ibid.

³⁶ Senate Summary, pp. 413-14. "Standard" interrogation techniques appear to have been first identified in a January 28, 2003 Guidance issued by CIA Director Tenet in response to the death of detainee Gul Rahman in CIA custody. See Senate Summary, pp. 62-63. In that Guidance, "standard" interrogation techniques were defined as those "that *do not* incorporate physical or substantial psychological pressure." See OIG report, Appendix E (emphasis in the original). The Guidance said they "include, but are not limited to, all lawful forms of questioning employed by US law enforcement and military interrogation personnel." Some examples included sleep deprivation up to 72 hours, isolation, loud music, and diapering generally not to exceed 72 hours.

³⁷ See section titled "The US Military's Approval and Use of Torture and Other Ill-Treatment" below. See also *Getting Away with Torture*.

³⁸ Rebecca Leung, "Abuse of Iraqi POWs by GIS Probed," *CBS News*, April 27, 2004, <http://www.cbsnews.com/news/abuse-of-iraqi-pows-by-gis-probed/> (accessed June 9, 2015); see also, Seymour M. Hersh, "Torture at Abu Ghraib," *The New Yorker*, May 10, 2004, <http://www.newyorker.com/magazine/2004/05/10/torture-at-abu-ghraib> (accessed June 6, 2015).

³⁹ Dana Priest and R. Jeffrey Smith, "Memo Offered Justification for Use of Torture," *Washington Post*, June 8, 2004, <http://www.washingtonpost.com/wp-dyn/articles/A23373-2004Jun7.html> (January 29, 2015); Dana Priest, "Justice Dept. Memo Says Torture 'May Be Justified,'" *Washington Post*, June 13, 2004, <http://www.washingtonpost.com/wp-dyn/articles/A38894-2004Jun13.html> (accessed August 18, 2015).

⁴⁰ OPR Report, p. 27.

Goldsmith reexamined the August 1, 2002 memos and concluded that the Bybee I Memo was “riddled with error” and a “one-sided effort to eliminate any hurdles posed by the torture law.”⁴¹ On May 3, 2004, in an attempt to get reassurance from OLC that they still endorsed the use of “enhanced interrogation techniques,” Muller wrote Goldsmith asking that he reaffirm OLC approval of the techniques as well as approve new ones.⁴² On May 27, Goldsmith wrote back to Muller saying that he “strongly recommended” that the CIA suspend use of waterboarding and review steps taken to ensure that in actual practice any use of CIA techniques “adheres closely to the assumptions and limitations in the August 2002 opinion [the Bybee memos].”⁴³ On June 15, 2004, Goldsmith withdrew the Bybee I Memo and submitted his letter of resignation the following day.⁴⁴ Goldsmith kept in place OLC approval for all of the enhanced interrogation techniques other than waterboarding but subject to the assumptions, limitations, and safeguards laid out in the Bybee II Memo, which had not been withdrawn.⁴⁵

Daniel Levin, who took over as acting head of the OLC after Goldsmith’s departure, inherited the task of issuing replacement memos for the Bybee I and Bybee II memos.⁴⁶ On August 6, 2004, he issued a memo authorizing waterboarding⁴⁷ and on December 30, 2004, issued a new legal opinion to replace the unclassified Bybee I Memo.⁴⁸ Levin’s replacement memo, like the Bybee I memo, analyzed the legal limits of the prohibitions on torture but it acknowledged that the prior legal reasoning was wrong.⁴⁹ Levin planned to draft a new memo to replace the classified Bybee II Memo as well but he left the office in February 2005 before he had finished those memos.⁵⁰

⁴¹ OPR Report, p. 160; see also Goldsmith, *The Terror Presidency*, p. 149.

⁴² Fax from Scott Muller, CIA General Counsel, to Jack Goldsmith, March 2, 2004 (hereinafter “Muller Fax”), <https://www.aclu.org/sites/default/files/torturefoia/released/o82409/olcremand/2004olc22.pdf> (accessed April 23, 2015).

⁴³ Letter from Jack Goldsmith to Scott Muller, May 27, 2004, <http://www.justice.gov/sites/default/files/olc/legacy/2009/08/24/memo-muller2004.pdf> (accessed August 26, 2015).

⁴⁴ OPR Report, p. 121. Goldsmith, *The Terror Presidency*, p. 159.

⁴⁵ OPR Report, p. 123.

⁴⁶ OPR Report, p. 124.

⁴⁷ OPR Report, p. 127.

⁴⁸ “Memorandum for James B. Comey, Deputy Attorney General, Re: Legal Standards Applicable Under 18 U.S.C. §§ 2340-2340A,” December 30, 2004, <https://www.aclu.org/files/torturefoia/released/o82409/olcremand/2004olc96.pdf> (accessed October 12, 2015) (hereinafter “Levin Replacement Memo”).

⁴⁹ “Levin Replacement Memo, p. 16, n. 27 (“In the August 2002 Memorandum, this Office concluded that the specific intent element of the statute required that infliction of severe pain or suffering be the defendant’s ‘precise objective’ and that it was not enough that the defendant act with knowledge that such pain ‘was reasonably likely to result from his actions’ (or even that the result ‘is certain to occur’). We do not reiterate that test here.”)

⁵⁰ OPR Report, pp. 122-131.

The OLC deputy head, Stephen Bradbury, temporarily took over Levin's vacant position. He issued two new memos, both on May 10, 2005, intended to replace the Bybee II classified memo. One discussed the legality of individual interrogation techniques and authorized all of the same techniques approved in the Bybee II memo, but with new legal reasoning ("Bradbury Individual Techniques Memo").⁵¹ The memo also authorized several techniques that had not been the subject of OLC opinions but had already been used by the CIA, such as "water dousing" and "nudity." The second May 10, 2005 memo addressed the techniques covered in the Bradbury Individual Techniques Memo but clarified that their use in combination with one another would not violate the Torture Statute ("Bradbury Combined Techniques Memo").⁵² Though previously not approved by official OLC memo on any detainee other than Abu Zubaydah, and even then only in cursory fashion,⁵³ the CIA had since the start of the program frequently used multiple "enhanced interrogation techniques" in combination.⁵⁴ A third memo, issued on March 30, 2005, analyzed whether the techniques would violate the prohibition against cruel, inhuman, or degrading treatment or punishment prohibited under the Convention against Torture, and found that they would not ("Bradbury CIDT Memo").⁵⁵

In December 2005, the US Congress passed the Detainee Treatment Act, which barred the use of cruel, inhuman, or degrading treatment or punishment against any detainee in US

⁵¹ "Memorandum for John A. Rizzo [Senior Deputy General Counsel, CIA]; Re: Application of 18 U.S.C. §§ 2340-2340A to Certain Techniques that May Be Used in the Interrogation of a High Value al Qaeda Detainee," May 10, 2005, http://media.luxmedia.com/aclu/olc_05102005_bradbury46pg.pdf (accessed January 29, 2015)(hereinafter "Bradbury Individual Techniques Memo").

⁵² Memorandum for John A. Rizzo [Senior Deputy General Counsel, CIA]; Re: Application of 18 U.S.C. §§ 2340-2340A to the Combined Use of Certain Techniques in the Interrogation of High Value al Qaeda Detainees," May 10, 2005, <http://www.justice.gov/sites/default/files/olc/legacy/2013/10/21/memo-bradbury2005-2.pdf> (accessed January 29, 2015)(hereinafter "Bradbury Combined Techniques Memo").

⁵³ Bybee II memo, p. 2, where use of the approved techniques "in some combination," in an "escalating fashion" on Abu Zubaydah is discussed in two sentences without any limitations placed on such combination or analysis thereof. By contrast, the Bradbury Combined Techniques Memo is a 20 page memo evaluating use of techniques in combination and noting that "a complete analysis under [the Torture Statute] ... entails an examination of the combined effects of any techniques that might be used." See also note 310 where the fact that Yoo admitted that his August 1, 2002 memos did not address the "cumulative effect" of the techniques is noted.

⁵⁴ Senate Summary Findings and Recommendations, p. 3.

⁵⁵ "Memorandum for John A. Rizzo [Senior Deputy General Counsel, CIA]; Re: Application of United States Obligations Under Article 16 of [Convention against Torture] to certain Techniques that May Be Used in the Interrogation of High Value al Qaeda Detainees," May 30, 2005, <http://www.justice.gov/sites/default/files/olc/legacy/2013/10/21/memo-bradbury2005.pdf> (accessed January 29, 2015)(hereinafter Bradbury CIDT Memo").

custody and required any detainee in the custody of the Defense Department to follow the US Army Field Manual on Intelligence Interrogations when conducting interrogations.⁵⁶ In a speech on September 6, 2006, President Bush formally disclosed the existence of the CIA interrogation program to the public.⁵⁷ He announced that a “small number” of detainees had been held by the CIA in locations that he could not disclose and praised the program for having “saved innocent lives.”⁵⁸ He also announced that the remaining 14 detainees in CIA custody at the time would be sent to the military detention facility at Guantanamo Bay. But he did not end the CIA program at this time. He said it needed to continue because it was “crucial to getting lifesaving information.”⁵⁹ As late as July 20, 2007, the OLC issued yet another memo authorizing the CIA to use techniques that were abusive, asserting that they would not violate US laws against torture and other ill-treatment or the newly enacted Detainee Treatment Act.⁶⁰

President Barack Obama, on his second full day in office on January 22, 2009, signed an executive order closing the CIA’s secret detention facilities and ending the use of “enhanced interrogation techniques.”⁶¹

The CIA Program: What Was Known before the Senate Summary

Before release of the Senate Summary, substantial information had already been published about the CIA program. As early as December 2002, accounts began to emerge of the CIA subjecting detainees to stress positions, unlawful renditions, and other forms of abuse.⁶² Following these initial reports, various media outlets and human rights

⁵⁶ Detainee Treatment Act of 2005, Public Law 163-109, 119 Stat. 3136, January 6, 2006, [https://www.icrc.org/ihl-nat/a24d1cf3344e99934125673e00508142/b22319aodaofa02c1257b8600397d29/\\$FILE/Detainee%20Treatment%20Act%20of%202005%20.pdf](https://www.icrc.org/ihl-nat/a24d1cf3344e99934125673e00508142/b22319aodaofa02c1257b8600397d29/$FILE/Detainee%20Treatment%20Act%20of%202005%20.pdf) (accessed June 10, 2015).

⁵⁷ “Transcript—President Bush’s Speech on Terrorism,” *New York Times*, September 6, 2006, http://www.nytimes.com/2006/09/06/washington/06bush_transcript.html?pagewanted=print (accessed June, 10 2015).

⁵⁸ *Ibid.*

⁵⁹ *Ibid.*

⁶⁰ Memorandum for John A. Rizzo, Acting General Counsel, Central Intelligence Agency, from Steven G. Bradbury, Principal Deputy Assistant Attorney General, Re: Application of the War Crimes Act, the Detainee Treatment Act, and Common Article 3 of the Geneva Conventions to Certain Techniques That May Be Used by the CIA in the Interrogation of High Value al Qaeda Detainees, July 20, 2007, <http://www.justice.gov/sites/default/files/olc/legacy/2009/08/24/memo-warcrimesact.pdf> (accessed June 10, 2015). Some of the abusive treatment approved included dietary manipulation, extended sleep deprivation, the facial hold, the attention grasp, the abdominal slap, and the insult slap.

⁶¹ Executive Order 13491, “Ensuring Lawful Interrogations,” signed January 22, 2009, <http://edocket.access.gpo.gov/2009/pdf/E9-1885.pdf> (accessed June 15, 2011).

⁶² Dana Priest and Barton Gellman, “U.S. Decries Abuse but Defends Interrogations,” *Washington Post*, December 26, 2002, <http://www.washingtonpost.com/wp-dyn/content/article/2006/06/09/AR2006060901356.html> (accessed August 21, 2015).

organizations sought to document CIA activities more extensively. As early as 2003, Human Rights Watch had already interviewed persons in Afghanistan with information about CIA detention and, in a series of reports on “Ghost Detainees,” we had published initial information on dozens of detainees who had disappeared into US custody.⁶³

Especially after news broke of torture and other abuse of detainees by the US military at Abu Ghraib, media outlets and rights organizations frequently reported on CIA abuse of detainees, US efforts to circumvent laws prohibiting torture and other ill-treatment, and the existence of secret CIA detention sites.⁶⁴

⁶³ Human Rights Watch, “*Enduring Freedom*”: *Abuses by U.S. Forces in Afghanistan*, vol. 16, no. 3(C), March 2004, <http://www.hrw.org/reports/2004/afghanistano304/afghanistano304.pdf>; Human Rights Watch, *The United States’ “Disappeared”*: *The CIA’s Long-Term “Ghost Detainees,”* October 12, 2004, <https://www.hrw.org/report/2004/10/12/united-states-disappeared-cias-long-term-ghost-detainees>; Human Rights Watch, *List of ‘Ghost Prisoners’ Possibly in CIA Custody*, November 30, 2005, <https://www.hrw.org/news/2005/11/30/list-ghost-prisoners-possibly-cia-custody>; Human Rights Watch, *Ghost Prisoner: Two Years in Secret CIA Detention*, Vol. 19, No. 1(G), February 27, 2007, <http://www.hrw.org/reports/2007/us0207/us0207webwcover.pdf>.

⁶⁴ A non-exhaustive list of just some of these materials includes “*Enduring Freedom*”: *Abuses by U.S. Forces in Afghanistan*; Human Rights First, “Ending Secret Detentions,” June 2004, <http://theopenunderground.de/@pdf/war/afghan/EndingSecretDetentions.pdf> (accessed August 21, 2015); Human Rights First, “Behind the Wire: An Update to Ending Secret Detentions,” March 2005, <http://www.humanrightsfirst.org/wp-content/uploads/pdf/behind-the-wire-033005.pdf> (accessed August 21, 2015); Amnesty International, “Five years on ‘the dark side’: A look back at ‘war on terror’ detentions,” December 13, 2006, <https://www.amnesty.org/en/documents/document/?indexNumber=amr51%2F195%2F2006&language=en>, (accessed June 11, 2015); Human Rights Watch, “Statement on US Secret Detention Facilities in Europe,” Human Rights Watch statement, November 6, 2005, <https://www.hrw.org/news/2005/11/06/human-rights-watch-statement-us-secret-detention-facilities-europe>; “US Operated Secret ‘Dark Prison’ in Kabul,” Human Rights Watch news release, December 20, 2005, <https://www.hrw.org/news/2005/12/19/us-operated-secret-dark-prison-kabul>; Human Rights Watch, *Off the Record: US Responsibility for Enforced Disappearances in the “War on Terror,”* June 7, 2007, <https://www.hrw.org/report/2007/06/07/record/us-responsibility-enforced-disappearances-war-terror>; Amnesty International, “Below the radar: Secret flights to torture and ‘disappearance,’” April 4, 2006, <https://www.amnesty.org/en/documents/AMR51/051/2006/en/> (accessed June 11, 2015); Human Rights Watch, “Letter to Bush Requesting Information on Missing Detainees,” February 27, 2007, <https://www.hrw.org/news/2007/02/26/letter-bush-requesting-information-missing-detainees>; *Delivered Into Enemy Hands*; Jane Mayer, “The Black Sites,” *The New Yorker*, August 13, 2007, <http://www.newyorker.com/magazine/2007/08/13/the-black-sites> (accessed June 11, 2015); Dana Priest, “CIA Holds Terror Suspects in Secret Prisons,” *Washington Post*, November 2, 2005, <http://www.washingtonpost.com/wp-dyn/content/article/2005/11/01/AR2005110101644.html> (accessed June 11, 2015); Priest Smith, “Memo Offered Justification for Use of Torture,” *Washington Post*; Dana Priest and Joe Stephens, “Secret World of U.S. Interrogation,” *Washington Post*, May 11, 2004, <http://www.washingtonpost.com/wp-dyn/articles/A15981-2004May10.html> (accessed October 13, 2015); Jane Mayer, *The Dark Side*, (New York: Anchor Books, 2008); Steve Coll, *Ghost Wars* (New York: Penguin Books, 2004); Michael Isikoff and David Corn, *Hubris* (New York: Three Rivers Press, 2006); The Constitution Project Report; OSJI, “Globalizing Torture: CIA Secret Detention and Extraordinary Rendition.”

The US Military's Approval and Use of Torture and Other Ill-Treatment⁶⁵

The harm of CIA torture was compounded by the US military's adoption of many of the CIA-approved interrogation techniques.

The military's use of the techniques dates to December 2001, when the Office of the Secretary of Defense inquired into the Survival, Evasion, Resistance, and Escape (SERE) program. SERE methods were being used by the military's Joint Personnel Recovery Agency (JPRA) to train US Special Forces to endure interrogation methods used by enemy forces that did not abide by the laws of armed conflict.⁶⁶ These techniques, many drawn from the experiences of US service members captured by North Korea during the Korean War, included stripping detainees naked for degradation purposes, exploiting cultural or religious taboos, use of forced standing, exposure to cold, and prolonged sleep deprivation.⁶⁷ The CIA later drew on these same SERE techniques to create its "enhanced interrogation" program.⁶⁸

In February 2002, JPRA personnel began providing training and written materials to personnel in or headed to Guantanamo and Afghanistan.⁶⁹ In July the CIA proposed the use of SERE-derived interrogation techniques with the first detainee held by the CIA, Abu Zubaydah. In mid-September 2002, just after the OLC issued its first memo authorizing CIA torture, JPRA staff began training Guantanamo personnel in the use of abusive SERE school techniques.⁷⁰

In late September 2002, a delegation of senior officials, including Defense General Counsel William Haynes, White House General Counsel Alberto Gonzales, CIA General Counsel John Rizzo, and Chief of the Criminal Division of the Justice Department Michael Chertoff, visited the military detention facility at Guantanamo to discuss how interrogations were being managed there.⁷¹ The evidence available suggests that the group encouraged the practices.⁷²

By October 2002 Guantanamo commander Maj. Gen. Michael Dunlavey was requesting authority to use more aggressive interrogation techniques including stress

⁶⁵ This box is primarily a summary of excerpts from *Getting Away with Torture*, which derived its information from a variety of sources. Additional sources are noted in the citations below.

⁶⁶ *Getting Away With Torture*, p. 40, citing SASC Report, p. 6.

⁶⁷ *Getting Away With Torture*, p. 41.

⁶⁸ *Getting Away With Torture*, p. 41.

⁶⁹ *Getting Away With Torture*, pp. 40-41.

⁷⁰ *Getting Away with Torture*, pp. 40-41, citing SASC Report, pp. 43-49.

⁷¹ *Getting Away with Torture*, pp. 41-42.

⁷² *Getting Away with Torture*, p. 42, citing Phillippe Sands, *Torture Team: Rumsfeld's Memo and the Betrayal of American Values* (New York: Palgrave Macmillan, 2008), p. 76.

positions; isolation for up to 30 days; deprivation of light and sound; exploiting individual phobias such as fear of dogs; forced grooming; use of scenarios designed to convince the detainee that death or severely painful consequences were imminent for him or his family; and waterboarding.⁷³

Haynes submitted a memo to Rumsfeld asking that he approve most of the methods Dunlavey requested, with the exception of waterboarding. On December 2, 2002, Rumsfeld approved most of the recommended techniques and appended a handwritten note to his authorization of these techniques: “I stand for 8-10 hours a day. Why is standing limited to 4 hours?”⁷⁴

Roughly two weeks later after concerns about Rumsfeld’s order were raised with Navy General Counsel Alberto Mora, Mora in turn, raised his concerns with Haynes among others. After asserting pressure but still not receiving assurances that the orders would be rescinded, Mora met with Haynes warning him that the “interrogation policies could threaten Secretary Rumsfeld’s tenure and could even damage the presidency.”⁷⁵ On January 15 2003, uncertain whether there would be any change to the interrogation policy, Mora

delivered a draft memorandum to Haynes stating that the majority of the proposed techniques violated domestic and international laws, at minimum constituting “cruel and unusual treatment and, at worst, torture.”⁷⁶ Mora told Haynes that he would not sign the memorandum unless Rumsfeld rescinded his order.⁷⁷ Rumsfeld did so on January 15, 2003 but at the same time said that commanders could get approval for the techniques if they asked for it and provided justification.⁷⁸ On April 16, 2003, Rumsfeld issued a new memorandum that, while more restrictive than the December 2002 rules, still allowed techniques that went beyond what the laws of war permitted, including isolation, dietary manipulation, and sleep adjustment.⁷⁹

Because of President Bush’s February 7, 2002 decision to reject the applicability of the Geneva Conventions to Al-Qaeda and Taliban prisoners in Afghanistan, there was no overarching prescribed interrogation regime for prisoners held there.⁸⁰ In late 2002, Special Mission Unit Task Force (SMU TF) officials from Afghanistan visited Guantanamo, compared notes on techniques from JPRA, and started drawing up a more formal list of techniques to be specifically authorized. A large portion of the SMU TF policies were based on Rumsfeld’s

⁷³ *Getting Away with Torture*, p. 42.

⁷⁴ *Getting Away with Torture*, p. 43.

⁷⁵ SASC Report, p. 107.

⁷⁶ SASC Report, p. 108.

⁷⁷ *Ibid.*

⁷⁸ *Getting Away with Torture*, pp. 44-45.

⁷⁹ SASC report. p. 132.

⁸⁰ *Getting Away with Torture*, p. 46.

December 2, 2002 authorization and the legal reasoning behind the denial of wartime protections to Al-Qaeda and Taliban prisoners.⁸¹

In January 2003, in response to a Joint Staff inquiry from US Central Command, the US military command in Afghanistan submitted a list of interrogation techniques then in use in Afghanistan. The list included techniques “similar” to those Rumsfeld had approved for Guantanamo even though that memo had been technically rescinded. When the command in Afghanistan received no complaints, it interpreted the silence to mean the techniques were unobjectionable.⁸²

Many US military and intelligence personnel sent to Iraq then based their interrogation policies on those formulated by the SMU TF in Afghanistan. For example, Capt. Carolyn Wood, who had helped develop interrogation policies for regular US forces in Afghanistan in late 2002—and who was implicated in the beating deaths of two detainees there in December 2002—was stationed in Iraq and put in command of Abu Ghraib interrogation operations in mid-2003. In July 2003, Captain Wood drafted a proposed interrogation policy based on the Afghanistan and Iraq SMU TF guidelines. This included the presence of military working

dogs, stress positions, sleep management, loud music, and light control.⁸³

Around the same time, in August 2003, Gen. Geoffrey Miller, who oversaw Guantanamo interrogation efforts, went to Iraq to conduct a counterterrorism assessment. He brought with him interrogation policy guidelines for Guantanamo that he gave to Gen. Ricardo Sanchez, the overall US military commander for Iraq, and proposed them as a model.⁸⁴ Sanchez used both Wood’s proposed policy and the Guantanamo guidelines to come up with interrogation guidelines for Iraq that he issued on September 14, 2003.⁸⁵ The abusive techniques approved, along with other techniques used by the SMU TF units, were among those being used at Abu Ghraib prison when the scandal connected to abuse there became public in 2004.⁸⁶

The US military record on criminal accountability for abuse of detainees post-9/11 has been abysmal. In 2007, Human Rights Watch collected information on some 350 cases of alleged abuse involving more than 600 military personnel. Few had been punished. The highest-ranking officer prosecuted for the abuse of prisoners was a lieutenant colonel, Steven Jordan, court-martialed in 2006 for his role in the Abu Ghraib scandal. He was acquitted in 2007.⁸⁷

⁸¹ Ibid.

⁸² Ibid.

⁸³ *Getting Away with Torture*, p 47; SASC report, p. 17.

⁸⁴ SASC Report, p. 197.

⁸⁵ SASC Report, p. 197.

⁸⁶ SASC Report, p. 197, 201.

⁸⁷ *Getting Away with Torture*, p. 6.

In 2003, several media outlets began to report on CIA interrogation techniques.⁸⁸ In March 2004 details of an army investigation into prisoner abuse in Iraq began to surface.⁸⁹ In April CBS published photos of the abuse at Abu Ghraib prison. And in May *The New Yorker* published an extensive expose about the abuse.⁹⁰ Then in June, one of the Bybee memos purportedly authorizing the CIA's use of "enhanced interrogation techniques" was leaked to the media.⁹¹

In subsequent years, media outlets and human rights groups documented or obtained information relating to the abusive interrogations of roughly 25 CIA detainees,⁹² but information on the treatment of scores of other detainees remains unavailable. Freedom of Information Act requests and lawsuits brought by the American Civil Liberties Union (ACLU) and others compelled the government to disclose a number of documents related to the CIA program.⁹³ But many other documents remain classified, including the September 17,

⁸⁸ Raymond Bonner, Don Van Natta Jr., and Amy Waldman, "Threats and Responses: Interrogations; Questioning Terror Suspects In a Dark and Surreal World," *New York Times*, March 9, 2003 <http://www.nytimes.com/2003/03/09/world/threats-responses-interrogations-questioning-terror-suspects-dark-surreal-world.html>; Jess Bravin and Gary Fields, "How Do Interrogators Make A Captured Terrorist Talk?" *Wall Street Journal*, March 4, 2003, <http://www.wsj.com/articles/SB1046732825540976880> (accessed August 18, 2015).

⁸⁹ Barbara Starr, "Soldiers charged with abusing Iraqi prisoners" *CNN*, March 20, 2003, <http://www.cnn.com/2004/US/03/20/iraq.prison.abuse/> (accessed August 18, 2015); Thom Shanker, "The Struggle for Iraq: The Military; 6 G.I.'s in Iraq Are Charged With Abuse Of Prisoners," *New York Times*, March 21, 2003 <http://www.nytimes.com/2004/03/21/world/struggle-for-iraq-military-6-gi-s-iraq-are-charged-with-abuse-prisoners.html> (accessed August 18, 2015).

⁹⁰ Rebecca Leung, "Abuse of Iraqi POWs by GIS Probed," *CBS News*, April 27, 2004, <http://www.cbsnews.com/news/abuse-of-iraqi-pows-by-gis-probed/> (accessed June 9, 2015); see also, Seymour Hersh, "Torture at Abu Ghraib," *The New Yorker*, May 10 2004, <http://www.newyorker.com/magazine/2004/05/10/torture-at-abu-ghraib> (accessed June 6, 2015).

⁹¹ Priest and Smith, "Memo Offered Justification for Use of Torture," *Washington Post*; Priest, "Justice Dept. Memo Says Torture 'May Be Justified,'" *Washington Post*.

⁹² A non-exhaustive list includes the accounts of 14 former CIA detainees documented in an International Committee of the Red Cross report that was leaked to the press in 2007 (See Mark Danner, "US Torture: Voices from the Black Sites," *New York Review of Books*, April 9, 2009, <http://www.nybooks.com/articles/archives/2009/apr/09/us-torture-voices-from-the-black-sites/>); The accounts of five former CIA detainees documented in the Human Rights Watch report, *Delivered Into Enemy Hands*; the accounts of plaintiffs who have brought suits in US courts, see e.g. the complaint in *Mohamed v. Jeppesen Dataplan, Inc.*, 539 F.Supp.2d 1128, (N.D. Cal. 2008) (No. 5:07-cv-02798), 2007 WL 2227631, pp. 3-13 (for more detail see individual declarations, e.g. "Declaration of Mohammed Farag Ahman Bashmilah in Support of the Plaintiffs' Motion to Dismiss or, in the Alternative, for Summary Judgment," (hereinafter "Bashmilah Declaration") <http://chrgj.org/wp-content/uploads/2012/07/declarationofbashmilah.pdf> (accessed June 27, 2014); Craig Smith, Souad Mekhennet, "Algerian Tells of Dark Term in U.S. Hands," *New York Times*, July 7, 2006, <http://www.nytimes.com/2006/07/07/world/africa/07algeria.html?pagewanted=all&gwt=pay> (accessed June 23, 2015); Clara Gutteridge, "How the US Rendered, Tortured and Discarded One Innocent Man," *The Nation*, June 27, 2012, <http://www.thenation.com/article/168621/how-us-rendered-tortured-and-discarded-one-innocent-man>; Human Rights Watch, "The Case Of Marwan Jabor," <http://www.hrw.org/reports/2007/uso207/2.htm> (accessed August 18, 2015); and the account of Suleiman Abdullah Salim in a complaint filed by the American Civil Liberties Union in *Abdullah Salim v. Mitchell*, Civil Action No. 2:15-CV-286-JLQ, October 13, 2015, https://www.aclu.org/sites/default/files/field_document/salim_v._mitchell_-_complaint_10-13-15.pdf (accessed October 14, 2015)(the other plaintiff in this case, Ben Soud, formerly went by the names of Mohamed Shoreiyya and Abd al-Karim; his account is documented in *Delivered into Enemy Hands* and to some extent in the Senate Summary).

⁹³ See e.g., American Civil Liberties Union, "Accountability for Torture," <https://www.aclu.org/feature/accountability-torture?redirect=accountability-torture> (accessed June 26, 2015); see also Jason Leopold and Ky Henderson, "Tequila, Painted Pearls, and Prada: How the CIA Helped Produce 'Zero Dark Thirty,'" *Vice News*, September 10, 2015,

2001 Memorandum of Notification purportedly granting the CIA authority to covertly capture and detain⁹⁴ individuals posing “a continuing, serious threat of violence or death to U.S. persons and interests or planning terrorist activities,” and 11 CIA Office of Inspector General reports related to the CIA program.⁹⁵

Justice Department Inquiry into CIA Torture

In 2007 reports emerged that the CIA had destroyed 92 videotapes depicting two CIA detainees, Abu Zubaydah and Abd al-Rahim al-Nashiri, being interrogated and subjected to the use of CIA torture techniques—including waterboarding.⁹⁶ In 2008, the US Department of Justice appointed Special Prosecutor John Durham to look into the tape destruction.⁹⁷ After Barack Obama took office, his attorney general, Eric Holder, expanded the Durham investigation to include a preliminary investigation into whether federal laws were violated as part of the CIA interrogation program.⁹⁸

Holder said his decision to expand the investigation was based in part on a report produced by the Justice Department’s Office of Professional Responsibility (OPR) finding that two OLC attorneys, John Yoo and Jay Bybee (see below), had engaged in professional misconduct in authorizing the CIA’s use of “enhanced interrogation techniques”⁹⁹ and

<https://news.vice.com/article/tequila-painted-pearls-and-prada-how-the-cia-helped-produce-zero-dark-thirty> (accessed October 14, 2015); Jason Leopold, “The Watchdog, the Whistleblower, and the Secret CIA Torture Report,” *Vice News*, May 19, 2015, <https://news.vice.com/article/the-watchdog-the-whistleblower-and-the-cias-secret-torture-report> (accessed October 14, 2015).

⁹⁴ Though the MON provides the CIA with “significant discretion in determining whom to detain, the factual basis for the detention, and the length of the detention,” Senator Feinstein, in her Forward to the Senate Summary writes: “It is worth repeating that the covert action authorities approved by the President in September 2001 did not provide any authorization or contemplate coercive interrogations.” See Senate Summary, p. 11, and Forward, p. 2, n. 2.

⁹⁵ Senate Summary, p. 11; Katherine Hawkins, “Disappearing People and Disappearing the Evidence: The Deeper Significance of the SSCI Report,” *Just Security*, August 15, 2004, <http://justsecurity.org/14054/guest-post-disappearing-people-disappearing-evidence-deeper-significance-ssci-report/> (accessed June 12, 2015). For a listing of documents withheld in the government’s response to an ACLU Freedom of Information Act (FOIA) lawsuit, see Letter from the US Department of Justice Civil Division, to the ACLU, November 14, 2011, https://www.aclu.org/sites/default/files/field_document/cia_vaughn_index_11142011.pdf (accessed June 10, 2015).

⁹⁶ Dan Eggen and Joby Warrick, “CIA Destroyed Videos Showing Interrogation,” *Washington Post*, December 7, 2007, http://www.washingtonpost.com/wp-dyn/content/article/2007/12/06/AR2007120601828_pf.html (accessed June 23, 2015); Mark Mazzetti, “U.S. Says C.I.A. Destroyed 92 Tapes of Interrogations,” *New York Times*, March 2, 2009, <http://www.nytimes.com/2009/03/03/washington/03web-intel.html> (accessed April 7, 2015).

⁹⁷ Eggen and Warrick, “Criminal Probe on CIA Tapes Opened,” *Washington Post*.

⁹⁸ Department of Justice, “Attorney General Eric Holder Regarding a Preliminary Review into the Interrogation of Certain Detainees,” August 24, 2009, <http://www.justice.gov/opa/speech/attorney-general-eric-holder-regarding-preliminary-review-interrogation-certain-detainees> (accessed February 19, 2015) (hereinafter “Attorney General August 24, 2009 Statement on Durham Investigation”).

⁹⁹ Attorney General August 24, 2009 Statement on Durham Investigation. See also OPR Report. Specifically the OPR Report found that Jay Bybee, Assistant Attorney General at the OLC committed “professional misconduct,” and John Yoo, Deputy

recommending that prior determinations by the Justice Department not to prosecute CIA abuses be reexamined.¹⁰⁰ (The OPR Report had not been made public at the time of Holder's announcement and was not disclosed until February 2010).¹⁰¹ It was also based on a then still-classified 2004 CIA Inspector General report.¹⁰²

Holder, however, also set strict limits to the Durham inquiry, making clear that "the Department of Justice will not prosecute anyone who acted in good faith and within the scope of the legal guidance given by the Office of Legal Counsel regarding the interrogation of detainees."¹⁰³ That preliminary investigation looked into 101 cases of alleged CIA abuse.¹⁰⁴

On November 9, 2010, Holder announced that the Justice Department would not press charges against anyone for destruction of the CIA videotapes depicting the interrogation of two detainees.¹⁰⁵ On June 30, 2011, he announced the closure, with no charges filed, in 99 of the 101 cases.¹⁰⁶ Holder provided little explanation for the decision not to press charges other than to say that Durham had concluded that many of the 101 detainees were never in CIA custody.¹⁰⁷ If that is the case it raises questions about who had custody of the detainees, where they were, and why this meant CIA personnel were not responsible for any wrongdoing.¹⁰⁸ Holder also said that he would open full investigations into the cases of the

Assistant Attorney General for the OLC "intentional professional misconduct" when they rendered legal advice in support of the CIA's use of so-called "enhanced interrogation techniques," OPR Report, p. 11.

¹⁰⁰ Attorney General August 24, 2009 Statement on Durham Investigation.

¹⁰¹ Eric Lichtblau and Scott Shane, "Report Faults 2 Authors of Bush Terror Memos," *New York Times*, February 19, 2010, http://www.nytimes.com/2010/02/20/us/politics/20justice.html?_r=0 (accessed June 24, 2015).

¹⁰² Attorney General August 24, 2009 Statement on Durham Investigation. The 2004 CIA Inspector General Report, dated May 7, 2009, was first released in a heavily redacted form by the George W. Bush administration in May 2008, then later in a less redacted form by the Obama administration on August 24, 2009. The latter version is available here: <http://graphics8.nytimes.com/packages/pdf/politics/20090825-DETAIN/2004CIAIG.pdf> (accessed June 26, 2015)(hereinafter "CIA OIG Report").

¹⁰³ Attorney General August 24, 2009 Statement on Durham Investigation.

¹⁰⁴ Department of Justice, "Statement of the Attorney General Regarding Investigation into the Interrogation of Certain Detainees," June 30, 2011, <http://www.justice.gov/opa/pr/statement-attorney-general-regarding-investigation-interrogation-certain-detainees> (accessed February 19, 2015)(hereinafter "Attorney General June 30, 2011 Statement on Durham Investigation").

¹⁰⁵ Jerry Markon, "No charges in destruction of CIA videotapes, Justice Department says," *Washington Post*, November 9, 2010, <http://www.washingtonpost.com/wp-dyn/content/article/2010/11/09/AR2010110904106.html> (accessed June 26, 2015).

¹⁰⁶ Attorney General June 30, 2011 Statement on Durham Investigation.

¹⁰⁷ *Ibid.*

¹⁰⁸ *Ibid.* David Passaro, the only CIA contractor or employee to be held criminally liable for detainee abuse, was prosecuted by the Department of Justice for the death of Abdul Wali, who died at a US military base in Kunar province in Afghanistan. See The Constitution Project Report, p. 74. Passaro was convicted of felony assault with a dangerous weapon and three counts of misdemeanor assault, for which he was sentenced in 2006 to eight years and four months in prison. For more information on Passaro's case, see "Anatomy of an Interrogation," *Retro Report*, April 19, 2015, <http://www.retroreport.org/video/anatomy-of-an-interrogation/> (July 21, 2015).

two remaining detainees, both of whom had died in US custody.¹⁰⁹ A year later, on August 30, 2012, Holder announced the closure of these cases without bringing any charges.¹¹⁰ In closing the investigation, Holder said he made his decision because “the admissible evidence would not be sufficient to obtain and sustain a conviction beyond a reasonable doubt.”¹¹¹

The Durham investigation was primarily focused only on CIA abuse that went beyond what was authorized.¹¹² This limitation was always too narrow in scope because the authorizations not only permitted interrogation methods in violation of US and international law, but also because they appear to have been designed specifically to create a legal escape hatch for what would otherwise be the illegal use of torture.

Even within the administration-imposed restraints, the investigation appears wholly inadequate. There is no evidence that Durham investigators interviewed any of the detainees in the CIA program, whether still detained or since released.¹¹³ In November 2014 five former CIA detainees who alleged that they had been badly tortured by the CIA

¹⁰⁹ Attorney General June 30, 2011 Statement on Durham Investigation; Eric Lichtblau and Eric Schmitt, “U.S. Widens Inquiries Into 2 Jail Deaths,” *New York Times*, June 30, 2011, <http://www.nytimes.com/2011/07/01/us/politics/01DETAIN.html>, (accessed April 7, 2015).

¹¹⁰ Department of Justice, “Statement of Attorney General Eric Holder on Closure of Investigation into the Interrogation of Certain Detainees,” August 30, 2012, <http://www.justice.gov/opa/pr/statement-attorney-general-eric-holder-closure-investigation-interrogation-certain-detainees> (accessed February 19, 2015)(hereinafter “Attorney General August 30, 2012 Statement on Durham Investigation”).

¹¹¹ *Ibid.* The basis upon which the Justice Department made this determination is not clear. When announcing closure of the investigation, the Justice Department put out a statement explaining that in making the determination not to bring charges, “Mr. Durham considered all potentially applicable substantive criminal statutes as well as the statutes of limitations and jurisdictional provisions that govern prosecutions under those statutes.” Attorney General August 30, 2012 Statement on Durham Investigation. Having “admissible evidence [that] probably will be sufficient to obtain and sustain a conviction” is consistent with determining whether to bring criminal charges according to the US Attorney Manual. The manual further states, “both as a matter of fundamental fairness and in the interest of the efficient administration of justice, no prosecution should be initiated against any person unless the government believes that the person probably will be found guilty by an unbiased trier of fact.” Department of Justice, US Attorneys’ Manual. “Grounds for Commencing or Declining Prosecution,” Title 9: Criminal, Section 9-27.220, <http://www.justice.gov/usam/usam-9-27000-principles-federal-prosecution#9-27.150> (accessed July 21, 2015).

¹¹² “Mr. Durham’s review examined primarily whether any unauthorized interrogation techniques were used by CIA interrogators, and if so, whether such techniques could constitute violations of the Torture Statute or any other applicable statute.” Attorney General June 30, 2011 Statement on Durham Investigation.

¹¹³ See Letter from five former CIA detainees alleging they had been subjected to CIA torture beyond what was authorized but yet were not interviewed for the Durham investigation. “Letter former CIA detainees to the United Nations Committee against Torture,” Human Rights Watch, November 14, 2014, <https://www.hrw.org/news/2014/11/14/letter-former-cia-detainees-united-nations-committee-against-torture>; Spencer Ackerman, “Former CIA Detainees Claim US Torture Investigators Never Interviewed Them,” *The Guardian*, November 11, 2014, <http://www.theguardian.com/us-news/2014/nov/11/libyan-cia-detainees-torture-inquiry-interview> (accessed February 12, 2014); Spencer Ackerman, “Doubt Cast Over US Torture Investigation as More CIA Detainees Come Forward,” *The Guardian*, November 12, 2014, <http://www.theguardian.com/us-news/2014/nov/12/more-cia-detainees-come-forward-us-investigation-torture> (accessed February 12, 2014). However, two attorneys representing two different former CIA detainees now held in Guantanamo told Human Rights Watch that Durham spoke to them during the course of his investigation about what happened to their clients while in CIA custody.

asserted in a public letter that Durham never spoke to them during his investigation.¹¹⁴ They urged the UN Committee against Torture to question the US delegation about this during the impending review of US compliance with the Convention against Torture.¹¹⁵ Other organizations working with former detainees held by the CIA and detainee defense counsel also report that the Durham team never spoke to their clients.¹¹⁶

When the Committee against Torture, charged with reviewing state compliance with the Convention against Torture, asked the US delegation whether any former detainees had been interviewed, the delegation was unwilling to provide an answer. Instead, David Bitkower, deputy assistant attorney general in the Justice Department's Criminal Division, newly disclosed that the Durham investigation had interviewed approximately 96 witnesses, but he would not say whether any of them were former CIA detainees.¹¹⁷ The US response provoked the following statement from the committee:

The Committee regrets ... that the delegation was not in a position to describe the investigative methods employed by Mr. Durham or the identities of any witnesses his team may have interviewed. Thus, the Committee remains concerned about information before it that some former CIA detainees, who had been held in U.S. custody abroad, were never interviewed during the investigations, casting doubts as to whether this high-profile inquiry was properly conducted.¹¹⁸

¹¹⁴ "Letter former CIA detainees to the United Nations Committee against Torture," Human Rights Watch, November 14, 2014, <https://www.hrw.org/news/2014/11/14/letter-former-cia-detainees-united-nations-committee-against-torture>.

¹¹⁵ *Ibid.*

¹¹⁶ Ackerman, "Doubt Cast Over US Torture Investigation as More CIA Detainees Come Forward," *The Guardian*.

¹¹⁷ Charlie Savage, "U.N. Commission Presses U.S. on Torture," *New York Times*, November 13, 2014, http://www.nytimes.com/2014/11/14/world/europe/un-commission-presses-us-on-torture.html?_r=0 (accessed February 12, 2014); "Full Transcript: US Third Periodic Report to UN Committee Against Torture, Nov. 12-13, 2014" *US Human Rights Network*, http://www.ushrnetwork.org/sites/ushrnetwork.org/files/cat_complete_transcript_from_just_security.pdf (accessed February 12, 2015). See p. 17 ("Why did the investigation not include victims of torture...?"); see also p. 23, p. 37, p. 46, and pp. 49-50 ("we have not acknowledged one way or the other who it is that the Durham investigation team interviewed or did not interview, and I am not in a position to do that today ... [We] interviewed approximately 96 different witnesses."). The *New York Times* and Charlie Savage have sued the Department of Justice for information related to the Durham investigation, including FBI witness statements. On September 30, 2015 a judge partially granted their request but denied their request for witness statements. It is not yet clear whether either party will appeal. See *New York Times and Charlie Savage v. the United States Department of Justice*, 14-cv-3777, Document 33, filed September 30, 2015, available at: <https://www.documentcloud.org/documents/2436601-savage-nyt-foia-durham-order.html> (accessed November 7, 2015).

¹¹⁸ UN Committee against Torture, "Concluding observations on the third to fifth periodic reports of United States of America," November 20, 2014, (CAT/C/SR. 1276 and 1277) <http://justsecurity.org/wp-content/uploads/2014/11/UN-Committee-Against-Torture-Concluding-Observations-United-States.pdf> (accessed April 23, 2015), para. 11. (The Committee against Torture further urged the US to "undertake a full review into the way the CIA's responsibilities were discharged in



Barbed wire fence surrounding a military area near Stare Kiejkuty village, where Polish prosecutors are investigating allegations the CIA ran a secret “black site.” © 2014 REUTERS/Kacper Pempel

New Details in the Senate Summary

The SSCI report is the product of six years of investigation by Senate Intelligence Committee staff members who had access to more than six million pages of CIA materials. These included operational cables, intelligence reports, internal memoranda, and emails, briefing materials, interview transcripts, contracts, and other records.¹¹⁹ Notably, the staff members did not have access to more than 9,400 documents that the CIA withheld,

relation to the allegations of torture and ill-treatment against suspects during U.S. custody abroad. In the event of a re-opening of investigations, the State party should ensure that any such inquiries are designed to address the alleged shortcomings in the thoroughness of the previous reviews and investigations.”).

¹¹⁹ Senate Summary, Forward, p. 5.

reportedly asserting the executive privilege on behalf of the White House.¹²⁰ The full 6,700-page report was completed in December 2012.¹²¹ However, it took nearly two years for the Senate Intelligence Committee to decide to release the Summary and for the US government to conduct declassification review. The Summary, still partially redacted, was released on December 9, 2014.¹²² It is 499 pages long; the remainder of the full report remains classified.

The Summary—and likely the full report—focuses exclusively on the CIA; it does not cover abuses by other US government agencies, including the military. It also does not address the issue of CIA renditions abroad. The Summary’s main findings are that the use of “enhanced interrogation techniques” was not an effective means of gathering useful intelligence; that the CIA inflated claims that the techniques were necessary to thwart terrorist attacks; and that the techniques used were far more brutal than previously thought.¹²³

The Summary covers many facts that were already well-known, but also includes many new details, including:

- A list of all detainees that the US government says it detained in the CIA detention and interrogation program. However, the US has still not released the names and identities of detainees the CIA did not itself hold for a significant time period but instead rendered to other countries.
- New details about the methods used in the CIA program. For example, the Summary discloses that the CIA subjected detainees to “rectal feedings,” in which CIA personnel forcibly inserted tubes into the rectums of detainees and infused pureed food into their bodies, which the Summary and medical experts conclude was not medically necessary.
- Evidence of interrogators’ intent to cause severe pain and suffering. This includes, for example, details on how interrogators used excessively large tubes to conduct

¹²⁰ Jonathan Landay, Ali Watkins, and Marisa Taylor, “White House withholds thousands of documents from Senate CIA probe, despite vows of help,” *McClatchy*, March 12, 2014, <http://www.mcclatchydc.com/2014/03/12/221033/despite-vows-of-help-white-house.html#storylink=cpy> (accessed January 20, 2015).

¹²¹ “US: Release Report that Addresses CIA Torture,” Human Rights Watch news release, December 13, 2012, <https://www.hrw.org/news/2012/12/13/us-release-report-addresses-cia-torture> (accessed July 1, 2015).

¹²² Senate Select Committee on Intelligence: Committee Study of the Central Intelligence Agency’s Detention and Interrogation Program, <http://www.intelligence.senate.gov/study2014/executive-summary.pdf> (accessed February 18, 2015).

¹²³ Senate Summary, Findings and Conclusions, pp. 1-3.

rectal feedings, or forced detainees into positions that required them to stand for days in order to deprive them of sleep when they already had broken bones in their legs, knowing it would cause permanent and lasting physical injury.

- The disclosure that the CIA paid the company that Mitchell and Jessen formed and was put in charge of implementing, carrying out and evaluating the effectiveness of the CIA program, \$81 million dollars.
- The disclosure that Federal Bureau of Prisons officials visited one of several CIA detention facilities in November 2002 in Afghanistan and were “wow’ed” by the degree of sensory deprivation there.
- Accounts of multiple detainees being subjected to water torture in ways that, according to an interrogator, were virtually “indistinguishable” from waterboarding and were unauthorized. Such accounts and prior reporting contradict Senate testimony by then-CIA Director Michael Hayden that only three detainees had ever been waterboarded.
- Evidence that the CIA recognized that the “enhanced interrogation techniques” were unlawful. This can be inferred from, among other things, the CIA’s request for Justice Department guarantees not to prosecute such practices under federal laws prohibiting torture and CIA lawyers’ acknowledgment in a draft letter to the US attorney general that use of “enhanced interrogation techniques” would be barred by anti-torture laws.
- Details about the various steps the CIA took to cover up possible criminal activity and obstruct the democratic process, including by making false claims to the Justice Department, the White House, and Congress about the scope, nature, successes, and necessity of the interrogation program.
- Efforts the administration took to keep senior members of its National Security Council and Defense Department team in the dark about the program.

The Senate Summary also places these and other facts in the context of US decision-making and explains how the Bush administration came to adopt, authorize, and approve a government-sanctioned program of torture and enforced disappearance around the globe. It should be recognized, however, that although the Senate Summary provides important new details about the interrogation program, it remains an account told largely

from the government’s perspective. The voices of the detainees who were subjected to torture are not included.

US Response to the Senate Summary

Evidence has long been available that US officials and agents violated US federal law, as well as international law, in connection with the CIA’s rendition, detention, and interrogation program.¹²⁴ Failure to prosecute torture is itself a violation of the Convention against Torture.¹²⁵ The release of the Senate Summary puts forward further evidence of wrongdoing that the US government is obligated under international law to investigate and appropriately prosecute, as well as provide redress to victims. However, the US has largely failed to act.

The Obama administration and others have put forward three broad reasons why the US need not and should not conduct criminal investigations into alleged abuses by US officials connected to the CIA interrogation program:

- “An investigation was already conducted”: The Obama administration’s main argument to justify no action is that it already conducted an investigation into these events, pointing to the Durham inquiry.¹²⁶
- “Prosecutions would be politically harmful”: President Obama famously said after his election but before taking office that he “had a belief that we need to look forward as opposed to looking backwards.”¹²⁷ Commentators supporting this

¹²⁴ See *Getting Away with Torture*, p. 49.

¹²⁵ Convention against Torture, art. 7.

¹²⁶ Carol Rosenberg, “Human rights groups ask attorney general to order new CIA torture probe,” *Miami Herald*, June 23, 2015, <http://www.miamiherald.com/news/nation-world/world/americas/guantanamo/article25313905.html> (accessed June 25, 2015). In response to the request for the Attorney General to order a new torture probe, the Justice Department issued the following response to this June 23, 2015 story: “In 2009, the Attorney General directed a preliminary review of the treatment of certain individuals alleged to have been mistreated while in U.S. Government custody subsequent to the 9/11 attacks. That review generated two criminal investigations, but the Department of Justice ultimately declined those cases for prosecution because the admissible evidence would not be sufficient to obtain and sustain convictions beyond a reasonable doubt. Those investigators have also reviewed the Senate Committee’s full report and did not find any new information that they had not previously considered in reaching their determination. This inquiry was extraordinarily thorough and we stand by our previously announced decision not to initiate criminal charges.” The statements contradict representations made by the Justice Department in ongoing freedom of information act litigation. According to a January 2015 declaration in *ACLU v. CIA*, the Justice Department’s copies of the full report have remained unopened and have not been reviewed by Justice Department staff or distributed in any way. See Letter to US Department of Justice Inspector General from Amnesty International USA, September 21, 2015, available at: <https://www.amnestyusa.org/pdfs/OIGComplaintAmnestyInternationalUSA.pdf> (accessed November 7, 2015), pp. 4-5.

¹²⁷ David Johnston and Charlie Savage, “Obama Reluctant to Look Into Bush Programs,” *New York Times*, January 11, 2009, http://www.nytimes.com/2009/01/12/us/politics/12inquire.html?_r=0 (accessed October 14, 2015).

approach contend that prosecutions, brought largely against Bush-era officials, would invariably be divisive for the nation.¹²⁸

- “Prosecutions of those involved in the CIA program are not viable under US law”: Some observers have concluded that it may not be possible to charge those responsible for CIA abuses due to difficulties in proving intent, the expiration of statutes of limitations, and the applicability of other defenses.¹²⁹

As mentioned above, international human rights law, notably the Convention against Torture and the International Covenant on Civil and Political Rights (ICCPR), obligates states to conduct impartial investigations and appropriately prosecute government officials responsible for torture and other cruel, inhuman, or degrading treatment or punishment.

The UN Committee against Torture has stated that a government’s obligation “to investigate, punish, and prevent further torture or ill-treatment in the future” should give “particular attention to the legal responsibility of both the direct perpetrators and officials in the chain of command, whether by acts of instigation, consent or acquiescence.”¹³⁰ The

¹²⁸ Johnston and Savage, “Obama Reluctant to Look Into Bush Programs,” *New York Times*; Kathleen Hennessey and Michael A. Memoli, “CIA torture report not likely to result in reforms or prosecutions,” *Los Angeles Times*, December 10, 2014, <http://www.latimes.com/world/middleeast/la-fg-torture-next-20141211-story.html> (“The Justice Department defended its decision not to prosecute those involved, saying the report would not trigger reconsideration” and additionally quotes Sen. Richard M. Burr as saying, “We’re going to focus on real-time oversight. We’re not going to be looking back at a decade trying to dredge up things.”); see also Raf Sanchez, “Why won’t Barack Obama prosecute CIA torturers?” *The Telegraph*, December 12, 2014, <http://www.telegraph.co.uk/news/worldnews/barackobama/11291476/Why-wont-Barack-Obama-prosecute-CIA-torturers.html> (accessed June 30, 2014) (“The release of the report has been explosive. Deep rifts between the CIA and the Democratic Party have erupted into public view. Morale has slumped at the spy agency and Republicans are accusing the White House of leaving America’s spooks to swing in the wind. Imagine how much worse all of that would be if the Obama administration was actually trying to send people to prison. The President would be prosecuting the friends and colleagues of the spies he relies on every day to keep the US safe from terrorism. If the Justice Department went after George W. Bush or Dick Cheney or other senior officials it would be seen as using the criminal justice system to persecute political opponents.”).

¹²⁹ Michael Mukasey, “The CIA Interrogations Followed the Law,” *Wall Street Journal*, December 16, 2014, <http://www.wsj.com/articles/michael-b-mukasey-the-cia-interrogations-followed-the-law-1418773648> (accessed April 21, 2015); John Yoo, “Dianne Feinstein’s Flawed Torture Report,” *Los Angeles Times*, December 13, 2014, <http://www.latimes.com/opinion/op-ed/la-oe-yoo-torture-feinstein-20141214-story.html#page=1> (accessed April 21, 2015); Jennifer Bendery and Ali Watkins, “Despite Torture Uproar, DOJ Still Says No To Prosecutions,” *Huffington Post*, December 9, 2014, http://www.huffingtonpost.com/2014/12/09/doj-torture_n_6298276.html?1418178014 (accessed March 9, 2015) (An unnamed US Justice Department spokesman, the day the SSCI report was released also alluded to the possibility that statutes of limitations, jurisdictional issues and legal opinions authorizing the abuse were bars to prosecution); “Statement of the Attorney General Eric Holder on Closure of Investigation into the Interrogation of Certain Detainees, August 30, 2012, <http://www.justice.gov/opa/pr/statement-attorney-general-eric-holder-closure-investigation-interrogation-certain-detainees> (accessed August 12, 2015) (Holder raised “statutes of limitations and jurisdictional provisions” in closing the only Justice Department investigation into widespread CIA abuses).

¹³⁰ UN Committee against Torture, General Comment No. 2, Implementation of article 2 by States Parties, U.N. Doc. CAT/C/CC/2, (2008), para. 7, <http://docstore.ohchr.org/SelfServices/FilesHandler.ashx?enc=6QkG1d%2fPPRiCAqhKb7yhskvE%2bTuw1mw%2fKU18dCyrY>

Committee considers it “essential” that the “responsibility of any superior officials, whether for direct instigation or encouragement of torture or ill-treatment or for consent or acquiescence therein, be fully investigated through competent, independent and impartial prosecutorial and judicial authorities.”¹³¹

The UN Human Rights Committee, the independent expert body that monitors state compliance with the ICCPR, has stated that where investigations uncover human rights violations, governments “must ensure that those responsible are brought to justice. As with failure to investigate, failure to bring to justice perpetrators of such violations could in and of itself give rise to a separate breach of the Covenant.” The Committee noted that impunity for arbitrary detention, torture and enforced disappearances, among other abuses, “may well be an important contributing element in the recurrence of the violations.”¹³²

Neither the Durham inquiry with its narrow mandate and inadequate investigation, nor Obama’s decision to give priority to political considerations, overcome US obligations under international law to prosecute serious human rights violations.

In the following section we will discuss in detail the third reason proffered not to prosecute, that prosecutions of US officials for torture may not or may no longer be legally viable.

rZhDDP8yaSRi%2fv43pYTgmQ5n7dAGFdDalfzYTJnWNYOXxeLRAIVgbwCsm2ZXH%2bcD%2b%2f6lTopc7BkgqlATQUZPVHi (accessed November 8, 2015).

¹³¹ Ibid., para. 26.

¹³² UN Human Rights Committee, General Comment 31, Nature of the General Legal Obligation on States Parties to the Covenant, U.N. Doc. CCPR/C/21/Rev.1/Add.13 (2004), para. 18, <http://docstore.ohchr.org/SelfServices/FilesHandler.ashx?enc=6QkG1d%2fPPRiCAqhKb7yhsjYoiCfMKoIRv2FVaVzRkMjTnjRO%2bfud3cPVrcM9YRoiW6Txaxgp3f9kUFpWoq%2fhW%2fTpKi2tPhZsbEJw%2fGeZRASjdFuuJQRnbJEaUhby31WiQPl2mLFDe6ZS wMMvmQGVHA%3d%3d> (accessed November 8, 2015).

II. Bringing Criminal Prosecutions in the US

There are several federal offenses that senior US officials, as well as other US personnel, can be charged with concerning the CIA's use of "enhanced interrogation techniques." The following sections discuss the main charges that should be considered. Not discussed here are possible charges against those alleged to have made false claims to federal officials or government bodies, or to have obstructed justice.

Substance of Potential Charges

The key charges are torture, conspiracy to torture, and conspiracy as a stand-alone crime. Assault, sexual abuse, war crimes and murder, as well as conspiracy to commit some of these crimes, are separate offenses that prosecutors can also pursue.¹³³

The level of culpability of those charged will vary widely depending on such factors as their involvement in authorizing and implementing or carrying out the program, whether their acts were authorized by the Justice Department, and whether mitigating circumstances apply. Charges could be brought for the actual completed offense or for attempting, or aiding and abetting, the offense.

Torture and Conspiracy to Torture

The US enacted what is referred to here as the Torture Statute to comply with its obligations under the Convention against Torture and Other Cruel, Inhuman or Degrading Treatment or Punishment (the Convention against Torture).¹³⁴ President Ronald Reagan had signed the Convention in 1988 and Congress enacted the Torture Statute in 1994 to comply with the Convention. Reagan said at the time the treaty was ratified that the US "will demonstrate unequivocally our desire to bring an end to the abhorrent practice of torture."¹³⁵

¹³³ The statutory sections include: torture (section 2340A(a)); conspiracy to torture (section 2340A(c)); conspiracy to commit other federal crimes (section 371); war crimes (section 2441); sexual abuse (sections 2241-2246); and murder (section 1111).

¹³⁴ See H.R. Conf. Rep. No. 103-482, p. 228 (1994); See the Torture Act 18 U.S.C. § 2340 (1994) (hereinafter "Torture Statute"). See Convention against Torture and Other Cruel, Inhuman or Degrading Treatment or Punishment, adopted December 10, 1984, G.A. Res. 39/46, annex, 39 U.N. GAOR Supp. (No. 51) at 197, U.N. Doc. A/39/51 (1984), entered into force June 26, 1987, art. 7, <http://www.ohchr.org/EN/ProfessionalInterest/Pages/CAT.aspx> (accessed November 12, 2015).

¹³⁵ "Message to the Senate Transmitting the Convention against Torture and Inhuman Treatment or Punishment," *The American Presidency Project*, May 20, 1988, <http://www.presidency.ucsb.edu/ws/?pid=35858> (accessed October 15, 2015).

The Torture Statute provides criminal penalties for torture, conspiracy to commit torture, and attempts to commit torture occurring outside the territorial jurisdiction of the United States, regardless of the citizenship of the perpetrator or victim.¹³⁶

The Torture Statute defines torture as “an act committed by a person acting under the color of law specifically intended to inflict severe physical or mental pain or suffering ... upon another person within his custody or physical control.”¹³⁷ To prosecute the crime of conspiracy to torture, prosecutors would have to prove the elements of conspiracy, as well as conspiracy to commit the offense of torture under the Torture Statute.

Legal Standards

Intent Required to Prove Torture

The definition of torture under the Convention against Torture requires that it be “intentionally inflicted.”¹³⁸ When ratifying the treaty, the US included an understanding containing similar wording—that in order for an act to constitute torture, it must be “specifically intended” to inflict severe physical or mental pain or suffering.¹³⁹ The US later included this “specifically intended” language in the Torture Statute.¹⁴⁰ The Senate Summary provides evidence of numerous instances in which US officials demonstrably sought to inflict severe pain or suffering. Even absent such specific intent, there are other serious crimes with which officials might be charged.

Federal courts have not interpreted the term “specifically intended” in reviewing a criminal case.¹⁴¹ However, several US courts have interpreted the language in the immigration

¹³⁶ Torture Act 18, U.S.C. § 2340A.

¹³⁷ Torture Act, 18 U.S.C. §. 2340(1).

¹³⁸ Convention against Torture, article 1.

¹³⁹ U.S. Reservations, Declarations, and Understandings, Convention against Torture and Other Cruel, Inhuman or Degrading Treatment or Punishment, 136 CONG. REC. S17486-01 (daily ed., Oct. 27, 1990), at 11(1)(a), <http://www1.umn.edu/humanrts/usdocs/tortres.html> (January 25, 2015). See Manfred Nowak and Elizabeth McArthur, *The United Nations Convention against Torture*, (Oxford: Oxford University Press, 2008), paras. 106-107.

¹⁴⁰ Torture Act, 18 U.S.C. sec. 2340(1).

¹⁴¹ Only one case has been brought under the US torture statute. It was brought against Charles “Chuckie” Taylor who was charged in 2006 for torture committed in Liberia and convicted in October 2008. His appeal, which he lost, did not challenge the court’s interpretation of “specifically intended.” See *United States v. Belfast*, 611 F.3d 783 (11th Cir. Fla. 2010); see also “Jury Convicts Taylor Jr. in First US Prosecution for Torture Abroad,” Human Rights Watch news release, December 10, 2008, <https://www.hrw.org/news/2008/12/10/jury-convicts-taylor-jr-first-us-prosecution-torture-abroad>; “Q & A: Charles ‘Chuckie’ Taylor, Jr.’s Trial in the United States for Torture Committed in Liberia,” Human Rights Watch Q & A, September 23, 2008 <https://www.hrw.org/news/2008/09/23/q-charles-chuckie-taylor-jrs-trial-united-states-torture-committed-liberia>. The trial court’s jury instructions regarding the meaning of “specifically intended” read: “The Defendant can be found guilty of that

context in deciding whether individuals have valid challenges to removal because they face torture in the country to which they would be transferred.¹⁴² In most of these cases courts have followed the lead of *Auguste v. Ridge*, a 2005 appellate court decision upholding an order of removal, which found that the “specifically intended” language in the Senate’s reservation requires a showing of the “specific intent” standard used in US criminal prosecutions.¹⁴³ The court noted that the specific intent standard is a “term of art” that is “well-known in American jurisprudence” meaning that “in order for an individual to have acted with specific intent, he must expressly intend to achieve the forbidden act.”¹⁴⁴

offense only if all of the following facts are proved beyond a reasonable doubt: First: That the Defendant committed an act with the specific intent to inflict severe physical pain or suffering ... Specific intent to inflict severe physical pain or suffering means to act with the intent to commit the act as well as the intent to achieve the consequences of the act, namely the infliction of the severe physical pain or suffering. An act that results in the unanticipated or unintended severity of pain and suffering is not torture.” *United States v. Belfast*, October 30, 2008, No. 06-20758-CR-ALTONAGA, 2008 WL 10908532.

¹⁴² After the US signed the Convention against Torture, Congress enacted legislation making it the policy of the United States not to “expel, extradite, or otherwise effect the involuntary return of any person to a country in which there are substantial grounds for believing the person would be in danger of being subjected to torture.” See Foreign Affairs Reform and Restructuring Act of 1988 (“FARRA”), Pub. L. No. 1005-277, Sec. 2242(b), 112 Stat. 2, 2681-821 (1988); 8 U.S.C. Sec. 1231(b)(3). Courts that have interpreted the meaning of “specifically intended” in the context of these removal proceedings include: *Auguste v. Ridge*, 395 F.3d 123, 144-45 (3d Cir. 2005); see also *Pierre v. Gonzales*, 502 F.3d 109, 117-118 (2d Cir. 2007); *Villegas v. Mukasey*, 523 F.3d 984, 989 (9th Cir. 2008).

¹⁴³ *Auguste v. Ridge*, 395 F.3d 123, 144-45 (3d Cir. 2005); *Auguste* overturned an earlier Third Circuit case *Zubeda v. Ashcroft*, 333 F.3d 463, 473 (3d Cir. 2003) (though the implementing legislation states that “in order to constitute torture, an act must be specifically intended to inflict severe physical or mental pain or suffering” the regulation then immediately explains: ‘[a]n act that results in unanticipated or unintended severity of pain and suffering is not torture.’ The intent requirement therefore distinguishes between suffering that is the accidental result of an intended act, and suffering that is purposefully inflicted or the foreseeable consequence of deliberate conduct. However, this is not the same as requiring a specific intent to inflict suffering.”). In reaching its decision, the *Auguste* court deferred to a Board of Immigration Appeals (BIA) interpretation of the Torture Statute under what is known as a *Chevron* deference standard—named after the case *Chevron, U.S.A., Inc. v. N.R.D.C.* *Chevron* held that agency determinations are accorded deference if Congress has not spoken to the issue and if the agency’s determination is neither arbitrary nor capricious. *Chevron*, 467 U.S. 837, 843-44 (1984). Applying this standard the *Auguste* court held that the BIA acted “reasonably” in mandating the use of a “specific intent” requirement. *Auguste*, pp. 144-45. Such deference would not apply in the criminal context because there would be no prior agency determination to defer to. Some academics have been critical of *Auguste*’s interpretation. See Redman, “Defining ‘Torture’: The Collateral Effect on Immigration Law of the Attorney General’s Narrow Interpretation of ‘Specifically Intended’ When Applied to United States Interrogators,” 62 *N.Y.U. Ann. Surv. Am. L.* 465-95 (2007); see also Irene Scharf, “Un-Torturing the Definition of Torture and Employing the Rule of Immigration Lenity,” 66 *Rutgers L. Rev.* 1, Fall 2013; Jens David Ohlin, “The Torture Lawyers: A Reply to Parry and Harel,” *Harvard International Law Journal Online*, vol. 51, June 2005, p.98, http://www.harvardilj.org/wp-content/uploads/2010/09/HILJ-Online_51_Ohlin.pdf (accessed Jan. 28, 2015). It is not clear that a court analyzing the type of intent required under the Torture Statute in a criminal case would come to the same conclusion as those that have analyzed it in the removal context. The fact that a court would be looking retrospectively at whether torture was inflicted rather than prospectively at whether someone faced a risk of torture might have an impact.

¹⁴⁴ *Auguste*, p. 145. (*Auguste* upheld an order of removal challenged by a US legal permanent resident with a criminal record who claimed he would be subjected to indefinite detention despite having served out his sentence, and torture, in Haiti’s abusive prison system. The court held that though Haitian prison conditions were “deplorable” and the conditions were used punitively by the government, just because Haitian authorities had knowledge that severe pain and suffering “may result,” does not mean they had the intent to inflict severe pain or suffering).

But in the criminal context, the meaning of “specific intent” is anything but clear.¹⁴⁵ As a respected treatise on criminal law notes, courts apply the meaning of “specific intent” in a variety of ways.¹⁴⁶ Some courts suggest that specific intent requires a conscious desire, or “purpose” to produce the proscribed result—in this case severe pain and suffering—“whatever the likelihood of that result happening from the conduct.”¹⁴⁷ Other cases suggest that only knowledge or notice that an act will likely result in the proscribed outcome is necessary for “specific intent” and that the notice element will be satisfied by the reasonable foreseeability of the natural and probable consequences of one’s act.¹⁴⁸

Some academics have challenged the notion that the Senate even intended to create a “specific intent” crime with its reservation to the treaty.¹⁴⁹ And, while the infamous Bybee

¹⁴⁵ See generally Wayne R. LaFare, “Sec. 5.2: Mental States: Intent and Knowledge,” in vol. 1 of *Substantive Criminal Law*, 2d ed. (Eagan, MN: Thomson/West, 2003), (Westlaw database updated September 2014), <https://1.next.westlaw.com/Browse/Home/SecondarySources/CriminalLawSecondarySources/CriminalLawTextsTreatises/SubstantiveCriminalLaw/> (accessed April 6, 2015).

¹⁴⁶ See Wayne R. LaFare, “Sec. 5.2: Mental States: Intent and Knowledge,” in vol. 1 of *Substantive Criminal Law* (“The meaning of the word ‘intent’ in criminal law has always been rather obscure ... ‘General intent’ is often distinguished from ‘specific intent,’ although the distinction being drawn by the use of these two terms often varies. ... greater clarity could be accomplished by abandoning the ‘specific intent’ - ‘general intent’ terminology.”).

¹⁴⁷ *U.S. v. Bailey*, 444 U.S. 394, 403-405 (1980)

¹⁴⁸ *United States v. Neiswender*, 590 F.2d 1269, 1273, (4th Cir. 1979). See also *United States Gypsum Co.*, 438 U.S. 422, 445 (U.S. 1978) (it is now generally understood that a person acts with specific intent when he “consciously desires that result, whatever the likelihood of that result happening from his conduct” and with general intent he “knows that the result is practically certain to follow from his conduct, whatever his desire may be as to that result.”)

¹⁴⁹ Where Congress seeks to require a showing of “specific intent” it uses that phrase. See Renee C. Redman, “Defining ‘Torture’: The Collateral Effect on Immigration Law of the Attorney General’s Narrow Interpretation of ‘Specifically Intended’ When Applied to United States Interrogators,” 62 *N.Y.U. Ann. Surv. Am. L.* 465, 493, n. 171 (2007) citing Brief of *Amicus Curiae* Allard K. Lowenstein International Human Rights Clinic in Support of Petitioner Guillaume’s Petition for a Writ of *Habeas Corpus*, March 30, 2006, http://www.law.yale.edu/documents/pdf/Intellectual_Life/Guillaume_Second_Circuit_Brief_FINAL_060330.pdf (accessed March 17, 2015), pp. 20-22. The brief reveals the results of a survey of the US Criminal Code finding only eight uses of the phrase “specifically intend[s][ed].” In six of these, Congress uses the phrase in contexts that clearly *do not* impose a “specific intent” requirement and have nothing to do with elements of a violation. Rather, in these sections, the word “specifically” is used as an adverb that modifies “intend[s][ed]” in a general sense, such as in 2 U.S.C. section 658b(d)(3) (2000), which discusses the duties of congressional committees and it states that if the bill or joint resolution would make a reduction, the Committee Report will contain: “a statement of how the committee specifically intends to implement the reduction.” In contrast, the section of the US code implementing the Genocide Convention states, “[w]hoever [commits a prohibited act] with the *specific intent to destroy*.” See Brief of *Amicus Curiae* Allard K. Lowenstein, p. 22, n. 11. (The only two sections where use of “specifically intend[s][ed]” could conceivably be an element of a violation were in the Torture Statute and in one other statute related to punitive damages. In the punitive damages statute it states that there will be no cap on punitive damages if the injury is ‘specifically intended’ but then defines specifically intended to mean when a “defendant acted with the specific intent to injure the plaintiff.”). See also Jens David Ohlin, “The Torture Lawyers: A Reply to Parry and Harel,” *Harvard International Law Journal Online*, vol. 51, June 2005, p.98, n. 15, http://www.harvardilj.org/wp-content/uploads/2010/09/HILJ-Online_51_Ohlin.pdf (accessed Jan. 28, 2015) (“The [torture] statute was not designed to allow potential perpetrators to open up a wedge between ‘pain’ and ‘severe pain’ and argue that they intended the former but did not specifically intend the latter. If this were the case, almost any torture prosecution would be frustrated when a perpetrator concedes that they intended to cause pain but then argue that the resulting severity was accidental. This is the wrong *mens rea* for torture.”).

Torture Memos of August 1, 2002 interpreted the Torture Act’s language as including a heightened specific intent requirement, less than two years later, the OLC would repudiate that interpretation (see below).¹⁵⁰ Regardless, even using the heightened standard articulated in *Auguste*, the available evidence indicates that the architects of the CIA Program specifically intended torture. Proof of that intent may be inferred from the total facts and circumstances of the case and does not require direct evidence of the accused’s mental state.¹⁵¹ In fact, the process that led to the creation of the Torture Memos, and the memos themselves, are evidence of intent to torture.

Elements of Conspiracy

Senior US officials who devised and authorized the CIA program did not actually carry out torture themselves, but there is a strong case that they engaged in a conspiracy to torture.¹⁵² In order to prove conspiracy under US law, there must be: (1) an agreement, (2) among two or more persons, (3) for an unlawful purpose, and (4) at least one overt act committed in furtherance of the conspiracy.¹⁵³ The overt act need not be illegal. It is also

¹⁵⁰ See Memorandum from Daniel Levin, Acting Assistant Attorney General, Office of Legal Counsel of the Justice Department, to James B. Comey, December 30, 2004, Re: Legal Standards Applicable Under 18 U.S.C. §§ 2340-2340A (hereinafter “Levin Replacement Memo”), p. 16, n. 27, <https://www.aclu.org/files/torturefoia/released/o82409/olcremand/2004olc96.pdf>. (“In the August 2002 Memorandum, this Office concluded that the specific intent element of the statute required that infliction of severe pain or suffering be the defendant’s ‘precise objective’ and that it was not enough that the defendant act with knowledge that such pain ‘was reasonably likely to result from his actions’ (or even that the result ‘is certain to occur’). We do not reiterate that test here.”)

¹⁵¹ Oona Hathaway, Aileen Nowlan, Julia Spiegel, “Tortured Reasoning: The Intent to Torture Under International and Domestic Law,” 52 *Virginia Journal of International Law* (2012), p. 791, 798, 805. (Analyzing the required mental state for torture in US jurisprudence in the extradition, civil and very limited criminal context and concluding that to the extent there are differences across different bodies of US domestic law they go to the evidence required to establish intent, rather than to the standard of intent itself).

¹⁵² Conspiracy to torture can be charged as one offense under 18 U.S.C. sec. 2340A(c), which permits the charge of conspiracy to torture, or by combining the stand-alone offense of conspiracy under the federal conspiracy statute, 18 U.S.C. section 371, with a charge of torture under the Torture Act 18 U.S.C. 2340A(a). The only difference appears to be what sentence can be imposed. See *US v. Parrett*, 872 F. Supp. 910, 911 (D. Utah 1994); see also *United States v. Bazzell*, 187 F.2d 878, 885 (7th Cir. 1951). Parrett analyzed whether it was proper to charge a defendant for conspiracy to kidnap using the federal conspiracy statute, 18 U.S.C. sec. 371, combined with the federal kidnapping statute, 18 U.S.C. sec. 1201(a), when essentially the same charge could be brought for conspiracy to kidnap under 18 U.S.C. sec. 1201(c) and held that either 18 U.S.C. sec. 371 combined with 18 U.S.C. sec. 1201(a) or 18 U.S.C. sec. 1201(c) on its own may be used—the only difference would be the penalty that could be imposed. Conspiracy to kidnap under section 1201(c) carries a maximum penalty of life imprisonment while conspiracy to kidnap using section 371 carries a maximum penalty of five years. There is no direct case on point looking at the same issue with regards to the charge of conspiracy to torture given the dearth of cases brought under the Torture Act (only one has been brought in US court, see *United States v. Belfast*, 611 F.3d 783, 793 (11th Cir. Fla. 2010)), but the statutory scheme of the federal kidnapping statute under 18 U.S.C. 1201 is virtually identical to that of the federal Torture Statute under 18 U.S.C. 2340A.

¹⁵³ *United States v. Cohen*, 583 F.2d 1030, 1039 (8th Cir. 1978); see also *United States v. Stone*, 323 F. Supp. 2d 886, 888 (E.D. Tenn. 2004).

necessary to demonstrate that conspirators intended to agree to commit elements of the underlying offense, in this case torture.¹⁵⁴

For conspiracy, the agreement can be inferred from direct or circumstantial evidence.¹⁵⁵ No proof of an express agreement is required. As one court noted, “criminal conspiracies are by their very nature clandestine, and a tacit agreement inferred from the surrounding circumstances can—and often does—suffice to ground a finding of willing participation.”¹⁵⁶

The crime is frequently established as a result of inferences drawn from the acts of persons accused.¹⁵⁷ Relevant circumstantial evidence can include: “the joint appearance of defendants at transactions and negotiations in furtherance of the conspiracy; the relationship among codefendants; mutual representation of defendants to third parties; and other evidence suggesting unity of purpose or common design and understanding among conspirators to accomplish the objects of the conspiracy.”¹⁵⁸

Individuals can also join a conspiracy if there is sufficient evidence they did so with some knowledge of the conspiracy's “unlawful aims”—in this case torture—and with the intent of helping the conspiracy succeed.¹⁵⁹ In addition, under the doctrine of “conscious

¹⁵⁴ *United States v. Heras*, 609 F.3d 101, 106 (2d Cir. N.Y. 2010); See also *United States v. Feola*, 420 U.S. 671, 686, 95 S. Ct. 1255, 43 L. Ed. 2d 541 (1975). As previously noted, the Torture Act defines torture as “an act committed by a person acting under the color of law specifically intended to inflict severe physical or mental pain or suffering ... upon another person under his custody or physical control.” Torture Act, 18 U.S.C. sec. 2340(1). 18 U.S.C. sec. 2340(2) further defines “severe mental pain or suffering” as “the prolonged mental harm caused by or resulting from— (A) the intentional infliction or threatened infliction of severe physical pain or suffering; (B) the administration or application, or threatened administration or application, of mind-altering substances or other procedures calculated to disrupt profoundly the senses or the personality; (C) the threat of imminent death; or (D) the threat that another person will imminently be subjected to death, severe physical pain or suffering, or the administration or application of mind-altering substances or other procedures calculated to disrupt profoundly the senses or personality.”

¹⁵⁵ Charles Doyle, “Federal Conspiracy Law: A Brief Overview,” *Congressional Research Service*, April 30, 2010, p. 5, n. 45, <https://www.fas.org/sgp/crs/misc/R41223.pdf> (accessed January 11, 2015) citing *United States v. Rodriguez-Velez*, 597 F.3d 32, 39 (1st Cir. 2010); *United States v. Johnson*, 592 F.3d 749, 754-55 (7th Cir. 2010); *United States v. Boria*, 592 F.3d 476, 481 (3d Cir. 2010); *United States v. Wardell*, 591 F.3d 1279, 1287 (10th Cir. 2009).

¹⁵⁶ *United States v. Rodriguez-Velez*, 597 F.3d 32, 39 (1st Cir. P.R. 2010).

¹⁵⁷ *Ibid.*

¹⁵⁸ Doyle, “Federal Conspiracy Law: A Brief Overview,” *Congressional Research Service*, p. 5-6, n. 46 citing *United States v. Wardell*, 591 F.3d, pp. 1287-288, which held “[b]ecause ‘secrecy and concealment’ are frequently essential to a successful conspiracy, ‘direct evidence of conspiracy is often hard to come by.’ Thus, ‘conspiracy convictions may be based on circumstantial evidence, and the jury may infer conspiracy from the defendants’ conduct and other circumstantial evidence indicating coordination and concert of action.”

¹⁵⁹ *U.S. v. Svoboda*, 347 F.3d 471, 477 (2d Cir. N.Y. 2003) citing *U.S. v. Reyes*, 302 F.3d 48, 53 (2d Cir. 2002). Another way courts put it is “whether there is proof that the defendant (1) had knowledge of the unlawful aims of the charged scheme and

avoidance,” knowledge can be found where a defendant consciously avoided learning the fact while aware of the high probability of its existence, even if there is no evidence that the defendant possessed actual knowledge.¹⁶⁰

Evidence of Conspiracy to Torture

There is substantial evidence supporting charges of conspiracy to torture against senior US officials and CIA contractors, including evidence that some individuals joined the conspiracy after it was first established.

Generating Legal Cover for Torture

After the US apprehension of Abu Zubaydah on March 28, 2002, someone identified as “CTC Legal” in the Senate Summary recommended that a psychologist working on contract in the CIA’s Office of Technical Services (OTS)—identified in the Senate Summary as Dr. Grayson Swigert—be used by the CIA to “provide real-time recommendations to overcome Abu Zubaydah’s resistance to interrogation.”¹⁶¹ Not long thereafter Swigert, since identified as James Mitchell, and another psychologist identified in the Senate Summary as Dr. Harold Dunbar, since identified as Bruce Jessen, proposed that the CIA use 12 interrogation techniques on detainees.¹⁶² These techniques included waterboarding, painful stress positions, walling, prolonged sleep deprivation, and cramped confinement among others— most of which were eventually approved for use by the OLC.¹⁶³ Mitchell and

(2) evinced, by his actions, an intention to further or promote its unlawful aims.” See *Svoboda*, p. 477, citing *U.S. v. Beech-Nut Nutrition Corp.*, 871 F.2d 1181, 1191 (2d Cir. 1989).

¹⁶⁰ *U.S. v. Svoboda*, 347 F.3d 471, 477-478 (2d Cir. N.Y. 2003).

¹⁶¹ Senate Summary, p. 26. Mitchell was known to CIA OTS because OTS had commissioned Mitchell and Jessen to prepare a report on an al-Qa’ida manual that was initially assessed by the CIA to include strategies to resist interrogation. The report was titled: “Recognizing and Developing Countermeasures to Al-Qaeda Resistance to Interrogation Techniques: A Resistance Training Perspective (undated),” Senate Summary, p. 21, 57.

¹⁶² Senate Summary, p. 32. Jason Leopold, “Psychologist James Mitchell Admits He Waterboarded al Qaeda Suspects,” *Vice News*, December 15, 2015, <https://news.vice.com/article/psychologist-james-mitchell-admits-he-waterboarded-al-qaeda-suspects> (accessed April 29, 2015); “CIA report: Who are the unlikely interrogators?” *BBC*, <http://www.bbc.com/news/world-us-canada-30405918> (accessed April 7, 2015).

¹⁶³ Senate Summary, p. 32. The express goal of the program was to induce a state of “learned helplessness.” OPR Report, p. 236. See also “Memorandum from CIA to OLC, Background Paper on CIA’s Combined use of Interrogation Techniques,” December 30, 2004, <https://www.aclu.org/sites/default/files/torturefoia/released/o82409/olcremand/2004olc97.pdf> (accessed November 16, 2015). “Learned helplessness” is a psychological theory, based on testing done on humans and animals, which holds that individuals forced to undergo painful or unpleasant stimuli will become unwilling to avoid further exposure to such treatment, presumably because they have learned that they cannot control the situation. Jeannette L. Nolen, “Learned helplessness,” *Encyclopedia Britannica*, <http://www.britannica.com/topic/learned-helplessness> (accessed November 11, 2015); See also American Psychological Association, “Report to the Special Committee of the Board of Directors of the American Psychological Association Independent Review Relating To APA Ethics Guidelines, National

Jessen were ultimately hired as contractors by the CIA to develop the “enhanced interrogation technique” program, carry it out, and assess its effectiveness.¹⁶⁴

Officials in the CIA and at the White House knew or should have known, from the moment these techniques were proposed, that they violated the Torture Statute. First, the techniques were derived from those used in the Defense Department’s Survival, Evasion, Resistance and Escape (SERE) program—a program designed to train US Special Forces to endure interrogation methods used by enemies who do not abide by the Geneva Conventions and the laws of war, which prohibit torture.¹⁶⁵ Second, the US Army’s field manual for intelligence investigations at the time prohibited many of the techniques the CIA was considering and ultimately approved using, such as “abnormal sleep deprivation” and “forcing an individual to stand, sit or kneel in abnormal positions for prolonged periods of time,” and “food deprivation,” explicitly defining them as forms of torture.¹⁶⁶

Indeed, the Senate Summary includes strong evidence that CIA and senior White House officials did know, practically from the moment that they were first being considered, that these techniques violated the Torture Statute. According to a Department of Justice Office

Security Interrogations, and Torture,” (hereinafter “Hoffman Report”) July 2, 2015, revised September 4, 2015, <http://www.apa.org/independent-review/revised-report.pdf> (accessed November 14, 2015), p. 529. “On the CIA’s behalf, the contract psychologists developed theories of interrogation based on ‘learned helplessness,’ and developed the list of enhanced interrogation techniques that was approved for use against Abu Zubaydah and subsequent CIA detainees,” Senate Summary, Findings and Conclusions, p. 11. The intended purpose was to force detainees to become “passive in response to adverse or uncontrollable events.” Senate Summary, Findings and Conclusions, p. 19, n. 32. CIA cables described the interrogations in the following manner: “the deliberate manipulation of the environment is intended to cause psychological disorientation, and reduced psychological wherewithal for the interrogation,” as well as “the deliberate establishment of psychological dependence upon the interrogator” Senate Summary, p. 26, n. 94. It can be argued that the psychological state of learned helplessness meets the definition of “severe mental pain or suffering” under the Torture Statute which is defined as “the administration or application, or threatened administration or application, of mind-altering substances or other procedures calculated to disrupt profoundly the senses or personality.” See 18 U.S.C sec. 2340.

¹⁶⁴ Senate Summary Findings and Conclusions, p. 11. See also Senate Summary, p. 32.

¹⁶⁵ Senate Summary, p. 21. See also “Statement of Senator Carl Levin on Senate Armed Services Committee Report of its Inquiry into the Treatment of Detainees in U.S. Custody,” December 11, 2008, <http://fas.org/irp/news/2008/12/levin121108.html> (accessed March 20, 2015); Among the physical and psychological pressures used at SERE schools are stress positions, sleep deprivation, face and abdomen slaps, isolation, degradation (such as treating the student like an animal), and “walling.” Until November 2007, waterboarding was also an approved training technique in the U.S. Navy SERE school. See SASC Report, p. 4.

¹⁶⁶ Department of the Army, *Field Manual 34-52: Intelligence Interrogation*, September 28, 1992, <http://fas.org/irp/doddir/army/fm34-52.pdf> (accessed February 2, 2015), Chapter 1, p. 8. This document was in effect until December 6, 2006 when it was replaced by the current US field manual for intelligence investigations on December 6, 2006. See “Human Intelligence Collection and Counterintelligence Operations” FM 2-22.3, p. ii (“This publication supersedes FM 34-52, 28 September 1992.”) <http://fas.org/irp/doddir/army/fm2-22-3.pdf> (accessed November 10, 2015). Food deprivation, or “dietary manipulation” as it was called was not officially approved in an OLC guidance memo until May 10, 2005. (See Bradbury Combined Techniques Memo, p. 7).

of Professional Responsibility investigation (OPR investigation), the CIA, through its acting General Counsel John Rizzo, expressed concern about “criminal liability” under the Torture Statute and sought a guarantee from the Justice Department that employees would not be prosecuted for use of these techniques.¹⁶⁷ The Senate Summary also contains reference to a draft letter to the attorney general from “CTC Legal” —a likely reference to someone in the legal department of the CIA’s counterterrorism center, headed by Jonathan Fredman at the time¹⁶⁸ —asking for an advance guarantee not to prosecute any US employees or agents using “aggressive methods” of interrogation and acknowledging that these methods would otherwise be prohibited by the Torture Statute.¹⁶⁹ The letter was drafted in July 2002 and circulated internally at the CIA, as well as to Mitchell, though the Senate Summary says there are no records showing that it was ever sent.¹⁷⁰ The existence of the letter indicates that CIA legal advisers believed from the beginning that the techniques being proposed were likely illegal.

At a July 13, 2002 meeting where the guarantee not to prosecute was discussed, Michael Chertoff, head of the Justice Department Criminal Division, refused to provide such a guarantee.¹⁷¹ At that same meeting, Daniel Levin, chief of staff to the FBI director at the time, also reportedly said that the FBI would not participate in any interrogations employing “enhanced interrogation techniques,” whether they were found legal or not and that the FBI would not further discuss the matter.¹⁷² Also present at the meeting was Rizzo;

¹⁶⁷ OPR Report, p. 37. As early as May 28, 2002, the day Abu Zubaydah was captured, CIA attorneys, including CTC Legal and Rizzo, discussed interpretations of the Torture Statute that might permit CIA officers to use certain interrogation tactics. See Senate Summary, p. 22, n. 61-62.

¹⁶⁸ See “Unclassified paper prepared by Jonathan Fredman for the Senate Armed Services Committee,” November 17, 2008, <https://www.emptywheel.net/wp-content/uploads/2013/04/Jonathan-Fredman-to-SASC.pdf> (accessed August 20, 2015). The paper states in part: “On September 11, 2001, I was chief legal counsel for the CIA Counterterrorist Center, or CTC....Among my responsibilities was to provide legal advice to the Director of CTC about proposed and ongoing operations conducted pursuant to written Presidential direction to CIA provided following the attacks of 9/11.” Fredman confirmed that these issues included “detention or interrogation,” and specifically interpretation of the anti-torture statute. Fredman wrote, “I stayed at my post in CTC until early April 2004,” and that “[a]s the chief counsel for CTC, I managed a legal staff that grew from three people in the days immediately before 9/11 to approximately 10 people thereafter.”

¹⁶⁹ Senate Summary, p. 33.

¹⁷⁰ *Ibid.*

¹⁷¹ OPR Report, p. 47. Sometime after this meeting, between July 13 and July 16, Chertoff asked Yoo to draft a letter from Yoo to Rizzo stating that after consultation with the Justice Department Criminal Division it is “our understanding” that the Department “does not issue letters of declination for future conduct that might violate federal law.” The letter was drafted and approved but there is no record it was ever sent. OPR Report, pp. 48-49.

¹⁷² OPR Report, p. 47 (Daniel Levin later served as Acting Deputy OLC, replacing Yoo and his role in that regard is discussed later in this report).

“CTC Legal”; legal advisor to the National Security Council John Bellinger; and Department of Justice OLC attorneys, including John Yoo.¹⁷³

At that point, senior White House officials, including Counsel to Vice President David Addington and White House Counsel Alberto Gonzales; CIA officials, including Rizzo; and the OLC’s Yoo engaged in a series of meetings and consultations in an apparent effort to generate novel legal cover for interrogation techniques that the CIA and others knew likely constituted torture. Eventually, these meetings led to the production of the first official memos, both issued on August 1, 2002, purporting to authorize the use of what the CIA referred to as “enhanced interrogation techniques.”

Evidence of the process by which the Bybee Memos were developed includes:

- At some point after Abu Zubaydah’s apprehension, the CIA asked the OLC for an opinion as to the legality of the proposed interrogation techniques.¹⁷⁴ Attorney General John Ashcroft instructed Yoo to draft the opinion.¹⁷⁵ Yoo began doing so after an April 16, 2002 meeting with unnamed individuals at the National Security Council.¹⁷⁶ Bellinger, having been told by CIA attorneys that they wanted to use “aggressive” interrogation techniques on Abu Zubaydah and that they wanted a guarantee that the Justice Department would not prosecute (known as a “declination of prosecution”), facilitated contact and meetings among the CIA, OLC, and Justice Department Criminal Division.¹⁷⁷ He also reportedly told Yoo that access to the interrogation program was extremely limited and that the State Department should not be informed.¹⁷⁸
- Sometime around July 8, 2002, as noted above, “CTC Legal” apparently drafted a letter, identified as a “draft” in the summary, to the attorney general asking that his office provide a guarantee not to prosecute in advance to any US employees or personnel who carry out interrogations on Abu Zubaydah that otherwise might

¹⁷³ Senate Summary, p. 33-34. Another report names Bellinger and places Gonzales at this meeting as well (see “Release of Declassified Narrative Describing the Department of Justice Office of Legal Counsel’s Opinions on CIA’s Detention and Interrogation Program,” April 22, 2009, http://fas.org/irp/congress/2009_rpt/ssci_olc.pdf (accessed March 15, 2015), p. 3).

¹⁷⁴ OPR Report, p. 37.

¹⁷⁵ OPR Report, p. 39.

¹⁷⁶ OPR Report, p. 40-43.

¹⁷⁷ OPR Report, pp. 37-43.

¹⁷⁸ OPR Report, p. 38.

subject them to criminal prosecution. The letter acknowledged that use of the “aggressive methods” would otherwise be prohibited by the Torture Statute “apart from potential reliance upon the doctrines of necessity or of self-defense.”¹⁷⁹ The letter was circulated internally at the CIA but there are no records to indicate it was provided to the attorney general.¹⁸⁰

- On July 12, 2002, Yoo met at the White House Counsel’s office with Gonzales and likely Addington¹⁸¹ about his memo, which Yoo reportedly referred to internally as the “bad things opinion.”¹⁸² At this point Yoo’s draft memo focused on the definition of torture, the ratification and negotiating history of the Torture Statute, and an analysis of what had been considered torture in prior cases.¹⁸³ It did not contain any arguments about whether the statute required specific intent to torture as an element; nor did it address any potential defenses to the statute in the case of prosecution.¹⁸⁴
- On July 13, 2002, the meeting where Chertoff refused to provide a guarantee not to prosecute and Levin said the FBI would not participate in interrogations, took place. After this, the OLC memos seem to have become more important to the CIA and senior officials at the White House, as they would need to rely upon them to justify the legality of the techniques.
- The same day as the July 13 meeting, at Rizzo’s request, Yoo drafted and two days later sent Rizzo a summary of the elements of the Torture Statute and how the specific intent required under it could be negated.¹⁸⁵ In a separate email to Rizzo on

¹⁷⁹ Senate Summary, p. 33.

¹⁸⁰ Senate Summary, p. 33.

¹⁸¹ The OPR report indicates Yoo and Gonzales met with either Flanigan or Addington at this meeting but subsequent testimony by Addington at a House Judiciary Committee hearing on June 17, 2008 indicates it was likely Addington at this and at a subsequent meetings with Yoo and Gonzales on July 16, 2002. See also SASC Report, p. 31. See OPR report, p. 52. Neither Addington nor Flanigan cooperated with the OPR Investigation, and neither Yoo, Gonzales nor an unnamed OLC attorney who helped Yoo with the memo and was also present at the July 12, 2002 meeting, said they had any specific recollection of whether it was Addington or Flanigan who was present. See OPR report, pp. 7 and 50. Whether Flanigan was present at other meetings, as well as his role in the initial conspiracy should be investigated however because other documents point to Flanigan as being a member of what was known as the “war council” that included Haynes, Gonzales, Rizzo, Yoo and Flanigan, who met regularly on a range of issues including interrogation of enemy combatants in the “war on terror” during the period that interrogation policy was being developed. SASC Report, p. 31, n. 224.

¹⁸² OPR Report, 45-46.

¹⁸³ OPR Report, pp. 45-46.

¹⁸⁴ OPR Report, p. 46.

¹⁸⁵ OPR Report, p. 48. Yoo’s letter stated that, “if an individual undertook any of the predicate acts for severe mental pain or suffering, but did so in the good faith belief that those acts would not cause the prisoner prolonged mental harm, he would not have acted with the specific intent necessary to establish torture. If, for example, efforts were made to determine what

July 15, likely in follow-up to the letter, Yoo also suggested to Rizzo “one other thing to include ... a footnote saying that we do not address because not asked” the following:(1) how Commander-in-Chief power affects enforcement of the Torture Statute; and (2) possible defenses to violations of the Torture Statute.¹⁸⁶

- The next day, July 16, Yoo met yet again with Gonzales and likely Addington.¹⁸⁷ After this meeting, Yoo began adding new sections to the memo on the Commander-in-Chief power and possible defenses to violations of the Torture Statute.¹⁸⁸ He also added in arguments about how specific intent could be negated.¹⁸⁹ A colleague of Yoo’s, Deputy Assistant Attorney General Patrick Philbin, noticed that the new sections were added and suggested they were “superfluous” and should be removed.¹⁹⁰ Yoo responded: “They want it in there.”¹⁹¹ The arguments remained in the analysis.¹⁹²
- Yoo provided regular briefings about the draft memorandums to Attorney General Ashcroft. He explained to him that the Justice Department Criminal Division had refused to provide the advance declination. At some point Ashcroft asked if it would be possible to issue advance pardons. Yoo informed Ashcroft it would not.¹⁹³
- On July 17, CIA director George Tenet met with National Security Adviser Condoleezza Rice, who told him that the CIA could proceed with its proposed

long-term impact, if any, specific conduct would have and it was learned that the conduct would not result in prolonged mental harm, any actions undertaken relying on that advice would have be [sic] undertaken in good faith. Due diligence to meet this standard might include such actions as surveying professional literature, consulting with experts, or evidence gained from past experience.” The final Bybee I Memo contained similar language. See Bybee I Memo, p. 8.

¹⁸⁶ OPR Report, p. 49.

¹⁸⁷ OPR Report p. 50. As described in more detail in note 181 above, the OPR Report is not clear whether Addington or Flanigan were present at this meeting. Flanigan’s and Addington’s role in this and subsequent meetings regarding interrogation policy need to be investigated.

¹⁸⁸ OPR Report, p. 49-53. The Commander-in-Chief power argument ended up as Part V of the Bybee I Memo, OPR Report, p. 68. The memo argued that interpreting the Torture Statute to prohibit the use of certain interrogation techniques used to gather information from the enemy would be unconstitutional because it would interfere with the president’s Commander-in-Chief power and authority to carry out a military campaign. See Bybee I Memo, p. 2 and pp. 31-39 (“Congress can no more interfere with the President’s conduct of the interrogation of enemy combatants than it can dictate strategic or tactical decisions on the battlefield.”). The common law defenses arguments ended up as Part VI of the Bybee I Memo. See OPR Report, p. 68. The memo argued that the common law defenses of necessity and self-defense “could provide justifications that would eliminate any criminal liability for violations of the torture statute.” Bybee I Memo, p. 39. For a full description of the argument, see Bybee I Memo, pp. 39-46.

¹⁸⁹ OPR Report, p. 53.

¹⁹⁰ OPR Report, p. 51. See also, p. 63, where Philbin is reported to have explained that he thought the analysis should have been limited to what the CIA could do within the law, including the defenses section, which he said “suggests that maybe there is something wrong. You’re going to have to use the defenses.”

¹⁹¹ OPR Report, p. 51.

¹⁹² See Bybee I Memo.

¹⁹³ OPR Report, p. 49.

interrogation of Abu Zubaydah, subject to the CIA providing more details about the techniques, an explanation as to why they would not cause lasting irreparable harm to Zubaydah, and a determination of legality by the OLC.¹⁹⁴

- The CIA gathered the requested information over the course of the following week.¹⁹⁵ The CIA asked Mitchell and Jessen about the possible psychological impact of using the waterboard or proposed “mock burial” techniques on Abu Zubaydah. Through a cable from the CIA Chief of Base, they responded that while SERE techniques are applied on volunteer students in a harmless way with no measurable psychological impact, they could not guarantee the same with Abu Zubaydah. While interrogation personnel will “make every effort” to ensure Abu Zubaydah is not “permanently physically or mentally harmed ... we should not say ... that there is no risk.”¹⁹⁶
- On July 24, the OLC orally advised the CIA that Attorney General Ashcroft had concluded that, with the exception of waterboarding, the proposed techniques—including the attention grasp, walling, the facial hold, the facial slap (insult slap), cramped confinement, wall standing, stress positions, sleep deprivation, use of diapers, and use of insects—could be used and were lawful.¹⁹⁷
- In apparent response to Rice’s request, Defense Department General Counsel William Haynes obtained two memos from JPRA staff.¹⁹⁸ The first dated July 25, 2002 listed lesson plans on “exploitation and interrogation” based on what had been effective against “Americans” in the past.¹⁹⁹ A second, dated July 26, 2002 had three attachments. The first included a list of techniques used to train SERE students to resist abusive interrogations; the second included operational risks, associated with the use of SERE-techniques (such as the danger of obtaining false information and that

¹⁹⁴ Senate Summary, pp. 34-36; “Release of Declassified Narrative Describing the Department of Justice Office of Legal Counsel’s Opinions on CIA’s Detention and Interrogation Program,” April 22, 2009, <http://www.intelligence.senate.gov/pdfs/olcopinion.pdf> (accessed March 15, 2015), pp. 3-4.

¹⁹⁵ Senate Summary, pp. 34-36.

¹⁹⁶ Senate Summary, p. 36. The waterboard was used for demonstration purposes on a very small number of students in limited applications during the SERE class and was ultimately discontinued in 2007 because of the dramatic effect on students subjected to it. CIA OIG Report, p. 14, n. 14. CIA detainees were waterboarded repeatedly over a very short amount of time. For example, Abu Zubaydah was waterboarded 2-4 times a day with multiple iterations of the watering cycle during each application. Senate Summary, p. 42.

¹⁹⁷ Senate Summary, pp. 36-37; “Release of Declassified Narrative Describing the Department of Justice Office of Legal Counsel’s Opinions on CIA’s Detention and Interrogation Program,” April 22, 2009, <http://www.intelligence.senate.gov/pdfs/olcopinion.pdf> (accessed March 15, 2015), pp. 3-4.

¹⁹⁸ See generally SASC Report, pp. 24-31, and specifically p. 26 where Haynes states that he was collecting the information for the Justice Department for “a program he was not free to discuss with the Committee, even in a classified setting.”

¹⁹⁹ SASC Report, p. 25. See also OPR Report, p. 56.

a detainee's resistance will increase), which were described interchangeably throughout the memo as "physical and psychological duress" and "torture;" and the third included information on the impact of SERE techniques used on SERE students which was described as "minimal"—though this was attributed to the voluntary nature of the program and extensive steps taken to ensure that the students suffered no long term harm.²⁰⁰ On July 26, Ashcroft orally approved the use of waterboarding.²⁰¹

- Sometime around July 26, and perhaps the same day, the CIA informed OLC that it wanted the approval in writing.²⁰² On July 26, the White House also told Yoo that they wanted the memos done "as soon as possible."²⁰³ Yoo then incorporated comments from Gonzalez, Chertoff, and Philbin into his drafts.²⁰⁴
- The final drafts of the two Bybee Memos, authored by Yoo, were issued on August 1, 2002. The second memo, addressed to Rizzo, invoked CIA consultations with individuals with extensive experience in the use of SERE techniques in justifying its claim that no prolonged mental harm would result from use of the "enhanced interrogation" methods.²⁰⁵

This sequence of meetings, correspondence, and events strongly suggest the involvement of senior White House and CIA officials in the production and content of the Bybee Memos. The OPR investigation came to a similar conclusion: "In view of this sequence of events, we believe it is likely that the sections [of the "August 1, 2002 Memos"] were added because some number of attendees at the July 16, 2002 meeting requested the additions, perhaps because the Criminal Division had refused to issue any advance declinations."²⁰⁶ The fact that the CIA's (CTC Legal's) July 8 draft letter recognized the importance of

²⁰⁰ SASC Report, pp. 24-31. See also, OPR Report, p. 56. One of the authors of these memos, Jerald Ogrisseg, has since stated that he produced his analysis with students in mind, not detainees, his analysis was not applicable to the offensive use of SERE techniques, and that he would not stand by the same conclusions if the SERE resistance training were being applied to detainees. SASC Report, p. 30. The nature of the SERE program included extensive physical and psychological pre-screening processes; a limited risk that SERE instructions would mistreat their own personnel; was voluntary in nature, of limited duration, had a known start and end date, and could be terminated by a student at any time. SASC Report, pp. 30-31.

²⁰¹ Senate Summary, pp. 36-37; "Release of Declassified Narrative Describing the Department of Justice Office of Legal Counsel's Opinions on CIA's Detention and Interrogation Program," April 22, 2009, <http://www.intelligence.senate.gov/pdfs/olcopinion.pdf> (accessed March 15, 2015), pp. 3-4.

²⁰² OPR Report, p. 56.

²⁰³ OPR Report, p. 57.

²⁰⁴ OPR Report, p. 57.

²⁰⁵ Bybee II Memo, p. 4. See also OPR Report, p. 56 and CIA OIG Report, p. 14.

²⁰⁶ OPR Report, p. 52.

“potential reliance upon the doctrines of necessity or of self-defense” to avoid liability under the Torture Statute strengthens this conclusion.

Ultimately, the OPR investigation found that Yoo violated his duty to exercise independent legal judgment, committing “intentional professional misconduct,” and that Bybee acted in “reckless disregard” of his obligations to provide independent legal analysis.²⁰⁷ The OPR investigation called for both lawyers to be referred to their respective state bar associations for discipline but in 2010 Associate Deputy Attorney General David Margolis rejected this recommendation.²⁰⁸

The meetings, correspondence, and events also provide evidence relevant to establishing the elements of a criminal conspiracy in that they are evidence of an agreement, among two or more persons (the senior administration officials involved in the meetings and authorizations above) for an unlawful purpose—the use of interrogation techniques that, individually, and certainly when combined as course of conduct, as discussed in more detail below, amounted to torture. Many of the individuals involved also appear to have engaged in overt acts in furtherance of the conspiracy—such as facilitating contact between parties that could approve use of the techniques, ensuring that relevant government officials who might object were not informed of the techniques, orally approving use of the techniques, drafting the memos or providing input for the content of the memos, approving the memos or techniques, giving orders in accordance with use of the techniques, and hiring psychologists Mitchell and Jessen to implement the program.²⁰⁹

²⁰⁷ OPR Report, p. 11. OPR recommended that both lawyers be referred to their respective state bar associations for discipline. Associate Deputy Attorney General David Margolis overruled the OPR’s recommended sanctions, however, finding that while Yoo and Bybee exercised “poor judgment,” they did not knowingly provide false advice, and therefore were not guilty of professional misconduct. Memorandum from David Margolis, associate deputy attorney general, to attorney general and deputy attorney general, regarding “Memorandum of Decision Regarding the Objections to the Findings of Professional Misconduct in the Office of Professional Responsibility’s Report of Investigation into the Office of Legal Counsel’s Memoranda Concerning Issues Relating to the Central Intelligence Agency’s Use of ‘Enhanced Interrogation Techniques’ on Suspected Terrorists,” (hereinafter “Margolis Memo”) January 5, 2010, https://www.aclu.org/files/pdfs/natsec/opr20100219/20100105_DAG_Margolis_Memo.pdf (accessed November 13, 2015), p. 68.

²⁰⁸ See *Ibid.* See also Margolis Memo, pp. 1-2.

²⁰⁹ Mitchell and Jessen had been psychologists with the US Air Force SERE program but the Senate Summary says they had no individual interrogation experience, specialized knowledge of Al-Qaeda, background in terrorism, or relevant regional, cultural, or linguistic expertise. Yet they were the ones who essentially designed the program that was ultimately approved. Senate Summary, p. 32. They were also in charge of carrying out the program and, in part, with evaluating its success. In its response to the Senate Summary, the CIA defended Mitchell and Jessen saying the Senate’s assertion that they had “no relevant experience” is “incorrect.” See “CIA Comments on the Senate Select Committee on Intelligence Report on the Rendition, Detention, and Interrogation Program,” June 27, 2003, https://www.cia.gov/library/reports/CIAs_June2013_Response_to_the_SSCI_Study_on_the_Former_Detention_and_Interrogation_Program.pdf (accessed November 16, 2015)(hereinafter “CIA Response”), p. 11 of the summary section.

Based on the information outlined above, the following individuals should be investigated for their role in the conspiracy: Acting CIA General Counsel John Rizzo, Head of the Justice Department OLC Jay Bybee, OLC Deputy Assistant Attorney General John Yoo, the person identified as “CTC Legal” in the Senate Summary, CIA Director George Tenet, National Security Legal Advisor John Bellinger, Attorney General John Ashcroft, White House Counsel Legal Advisor Alberto Gonzales, Counsel to the Vice President David Addington, Deputy White House Counsel Timothy Flanigan, and National Security Advisor Condoleezza Rice.

President Bush and Vice President Cheney should also be investigated for their roles in approving torture. The Senate Summary indicates that Bush was not briefed on the CIA program until April 8, 2006 and that at that time he “expressed discomfort” at the image of a detainee chained, diapered, and forced to go to the bathroom on himself.²¹⁰ However, Bush admits in his autobiography that he discussed the program with Tenet in 2002, prior to application of the first techniques, and personally approved them.²¹¹ Further, a still-classified Memorandum of Notification for covert action, signed by Bush on September 17, 2001, provided the purported basis for authorization of the CIA program, though apparently not for the use of coercive interrogations.²¹² More about Cheney’s role after the “Torture Memos” were issued is elaborated on below, but media reports indicate that he, together with Addington, was the principal political force pressing OLC lawyers to justify the use of coercive interrogation methods.²¹³ As Cheney notably said during a media interview in which he defended the actions of Yoo and other OLC lawyers, the lawyers did “what we asked them to do.”²¹⁴

²¹⁰ Senate Summary, p. 40.

²¹¹ Senate Summary, p. 40, n. 177.

²¹² Senate Summary, p. 11-13. The MON made no reference to interrogations or interrogation techniques but provided the CIA director with “unprecedented authorities” and “significant discretion” to detain persons posing a “continuing, serious threat” to the US. However, Senator Feinstein’s Forward to the Summary notes that the MON did not provide authorization or contemplate the use of coercive interrogations. Senate Summary, p. 2, n. 2. See also, Senate Summary, p. 11.

²¹³ See *Getting Away with Torture*, p. 74, n. 278 stating: Cheney has been described by one author as the “single-minded driving force behind the most aggressive aspects of the Bush administration’s counterterrorism policy,” (Mayer, *The Dark Side*, p. 343) and by the *Washington Post* as “a prime mover behind the Bush administration’s decision to violate the Geneva Conventions and the U.N. Convention Against Torture.” (“Vice President for Torture,” *Washington Post*, October 26, 2005, <http://www.washingtonpost.com/wp-dyn/content/article/2005/10/25/AR2005102501388.html> (accessed November 13, 2015)). See also “Cheney, Rice Approved Use of Waterboarding, Other Interrogation Tactics,” *Associated Press*, April 11, 2008, <http://www.foxnews.com/story/2008/04/11/cheney-riche-approved-use-waterboarding-other-interrogation-tactics/> (accessed April 5, 2015).

²¹⁴ “Transcript of Interview with Vice President Dick Cheney,” *ABC’s This Week*, p. 9 (Feb. 14, 2010), available at <http://abcnews.go.com/ThisWeek/week-transcript-vice-president-dick-cheney/story?id=9818034&singlePage=true> (accessed January 12, 2015); see also Testimony of David Addington, former counsel to the vice president, before the House Judiciary Committee Subcommittee on the Constitution, Civil Rights, and Civil Liberties, “In defense of Mr. Yoo, I would simply like to point out that is what his client asked him to do. So it is the professional obligation of the attorney to render the advice on the subjects that the client wants advice on.” (The Constitution Project Report, p. 132 citing hearing testimony).

Mitchell and Jessen should be investigated for their alleged direct participation in torture, often applied in ways beyond how it was authorized, but also for their role in the initial conspiracy to torture as well. As the Senate Summary points out, it was Mitchell who first proposed the use of 12 specific techniques derived from the US Military's SERE school on Abu Zubaydah (see above) to the CIA.²¹⁵ Both Jessen and Mitchell had been psychologists with the US Air Force SERE school so they would have known the school exposed trainees to interrogation methods that would violate the Geneva Conventions and the laws of war.²¹⁶ "CTC Legal's" draft letter to Ashcroft asking for a guarantee to prosecute was circulated to Mitchell.²¹⁷ Also in July, Mitchell proposed the CIA enter into a contract with Jessen to aid the CIA in its interrogation process.²¹⁸ At some point, Mitchell and Jessen, perhaps not until 2005, formed the company Mitchell Jessen & Associates along with other former JPRA officials and SERE school employees or contractors.²¹⁹ They received \$81 million on their \$180 million contract with the CIA to carry out the program before it was terminated in 2009.²²⁰ The contract was to assess detainees' fitness for the use of "enhanced interrogation techniques," conduct interrogations, and to assess the effectiveness of the techniques as applied.²²¹

In late July as Yoo was finishing up the August 1, 2002 memos, he received a psychological assessment of Abu Zubaydah and a report from CIA psychologists asserting that the use of harsh interrogation techniques in SERE training had resulted in no adverse long-term

²¹⁵ Senate Summary, p. 32, n. 138 ("The CIA did not seek out Swigert and Dunbar after a decision was made to use coercive interrogation techniques; rather Swigert and Dunbar played a role in convincing the CIA to adopt such a policy.").

²¹⁶ Senate Summary, p. 21. See also "Statement of Senator Carl Levin on Senate Armed Services Committee Report of its Inquiry into the Treatment of Detainees in U.S. Custody," December 11, 2008, <http://fas.org/irp/news/2008/12/levin121108.html> (accessed October 25, 2015) ("The SERE techniques] were designed to give our students a taste of what they might be subjected to if captured by a ruthless, lawless enemy so that they would be better prepared to resist. The techniques were never intended to be used against detainees in U.S. custody SERE training is based on illegal exploitation [of the Geneva Conventions] over the last 50 years.").

²¹⁷ Senate Summary, p. 33. Mitchell by this time was already on contract with the CIA's Office of Technical Services and had been involved in Abu Zubaydah's initial interrogations. Senate Summary, p. 26.

²¹⁸ Senate Summary, p. 32.

²¹⁹ There are conflicting reports about when the company was formed. The Hoffman Report says that Mitchell and Jessen formed the company in July 2002. Hoffman Report, p. 128. The SASC Report says Mitchell and Jessen formed the company after Jessen retired from the Department of Defense which was in July 2002. SASC Report, pp. 22-23. However, the Senate Summary says Mitchell and Jessen formed company "Y" in 2005. Senate Summary, p. 168. See also CIA response, p. 48, Conclusion 12. In either case each of these sources agree that the company was co-owned by seven individuals, six of whom either worked for JPRA or one of the service SERE schools as employees or contractors. See Hoffman Report, p. 128. SASC Report, pp. 23-24, and Senate Summary, p. 168.

²²⁰ Senate Summary, Findings and Conclusions, p. 11. See also Senate Summary, p. 168.

²²¹ Hoffman Report, p. 128, citing SASC Report, p. 24. In May 2004 the CIA's policy changed and thereafter Mitchell and Jessen acted only as interrogators. See Hoffman Report, p. 128 citing "Memorandum from John Brennan, Director, Central Intelligence Agency, to Sen. Dianne Feinstein and Sen. Saxby Chambliss, CIA Comments on the Senate Select Committee on Intelligence Report on the Rendition, Detention, and Interrogation Program" (June 27, 2013).

effects.²²² The August 1, 2002 memo (Bybee II Memo) to John Rizzo relied in part upon the psychological assessment of Abu Zubaydah sent to Yoo on July 24, 2002.²²³ Whether Mitchell, Jessen, or anyone from the company played a role in making these assessments should be investigated. The author of the July 24, 2002 psychological assessment is not clear but the Senate Summary indicates that Mitchell was present during interrogation sessions with Abu Zubaydah and likely produced a psychological assessment of him.²²⁴ The Senate Summary documents concerns raised in CIA cables about a conflict of interest inherent in having Mitchell and Jessen in charge of conducting psychological assessments of detainees, the appropriateness of the application of “enhanced interrogation techniques” on them, as well as the effectiveness of the techniques.²²⁵ The CIA admits the multiple roles of Mitchell and Jessen raised conflict of interest concerns, especially early on in the program.²²⁶

Defining “Humane Treatment”

Other government documents, related to later stages of the CIA program, provide further evidence that those named above were part of the conspiracy, and that others joined the conspiracy at a later date. Specifically, there is evidence in the public record indicating that senior US officials or government agents, both had knowledge of the “unlawful aims”

²²² OPR Report, p. 56.

²²³ See Bybee II Memo, pp. 7-9, which uses the exact language used in the psychological assessment faxed to Yoo on July 24, 2002. See “Psychological Assessment of Abu Zubaydah,” faxed to John Yoo on July 24, 2002, *ACLU: The Torture Data Base*, https://www.thetorturedatabase.org/document/cia-memo-psychological-assessment-abu-zubaydah?search_url=search/apachesolr_search&search_args=page=3 (accessed July 23, 2015). The Bybee II Memo to the CIA on August 1, 2002 concludes:

As described above, it appears you have conducted an extensive inquiry to ascertain what impact, if any, these procedures individually and as a course of conduct would have on Zubaydah. You have consulted with interrogation experts, including those with substantial SERE school experience, consulted with outside psychologists, completed a psychological assessment and reviewed the relevant literature on the topic. Based on this inquiry, you believe that the use of the procedures, including the waterboard, and as a course of conduct would not result in prolonged mental harm. Reliance on this information about Zubaydah and about the effect on the use of these techniques more generally demonstrates the presence of a good faith belief that no prolonged mental harm will result from using these methods in the interrogation of Zubaydah. Moreover, we think that this represents not only an honest belief but also a reasonable belief based on the information that you have supplied to us. Thus, we believe that the specific intent to inflict severe mental pain or suffering is not present, and consequently there is no specific intent to inflict severe mental pain or suffering.

²²⁴ See Senate Summary, p. 26 stating that the CIA sent Mitchell as part of an interrogation team to where Abu Zubaydah was being detained shortly after Abu Zubaydah’s capture. An FBI interrogation team sent a memo to FBI headquarters at the time stating that CIA psychologists had acquired “tremendous influence” in questioning Abu Zubaydah. Senate Summary, p. 27.

²²⁵ Senate Summary, p. 65. “In a communication to the CIA Inspector General, someone from the CIA’s Office of Medical Services writes, “OMS’ concerns about conflict of interest were nowhere more graphic than in the setting in which the same individuals applied an EIT which only they were approved to employ, judged both its effectiveness and detainee resilience, and implicitly proposed continued use of the technique—at a daily compensation reported to be \$1800/day, or four times that of interrogators who could not use the technique.”

²²⁶ CIA Response, p. 10, para. 32.

of the conspiracy—using torture to “enhance” interrogations—or made a deliberate effort to avoid knowing that torture was being used.

In late 2002, CIA officials appear to have grown concerned that President Bush and other senior officials were not fully behind their use of the “enhanced interrogation techniques,” and sought reassurance that they had approval to proceed.²²⁷

The concern stemmed from a memo that Bush issued on February 7, 2002, declaring that the Geneva Conventions did not apply to Taliban and Al-Qaeda detainees but that the US armed forces would nevertheless treat detainees “humanely.”²²⁸ The CIA’s concerns were compounded by various communications it received about detainee treatment after it began using the OLC-approved techniques. As a result, then-CIA General Counsel Scott Muller decided to draft a “Memorandum for the Record,” dated February 12, 2003, memorializing conversations he had with senior members of the administration confirming that the February 7, 2002 memo did not impose new requirements on the CIA to treat detainees “humanely.”²²⁹ The memo mentioned conversations about a letter from Secretary of Defense Donald Rumsfeld addressed to George Tenet, and received by the CIA on November 26, 2002, raising the requirement of humane treatment articulated in the president’s February 7, 2002 memo in relation to the transfer of a detainee from the

²²⁷ See David Cole, “The New Torture Files’: Declassified Memos Detail Roles of Bush White House and DOJ Officials Who Conspired to Approve Torture,” *Just Security*, March 2, 2015, <http://justsecurity.org/20553/new-torture-files-declassified-memos-detail-roles-bush-wh-doj-officials-conspired-approve-torture/> (March 15, 2015); see also, Cole, “Torture: No One Said No,” *New York Review of Books*; Senate Summary pp. 115-119; *Getting Away With Torture*, pp. 30-31, citing Senate Select Committee on Intelligence (SSCI), “Declassified Narrative Describing the Department of Justice Office of Legal Counsel’s Opinions on the CIA’s Detention and Interrogation Program,” document released April 22, 2009, <http://www.intelligence.senate.gov/publications/declassified-narrative-olc-opinions-cia-detention-and-interrogation-program-april-17> (accessed June 28, 2015), pp. 7; John Sifton, “New Torture Report Details Bushies’ Role,” *The Daily Beast*, April, 22, 2009, <http://www.thedailybeast.com/articles/2009/04/22/new-torture-report-details-bushies-role.html> (accessed June 28, 2015).

²²⁸ Memorandum from President George W. Bush to the vice president, secretary of state, secretary of defense, attorney general, chief of staff to the president, CIA director, assistant to the president for National Security Affairs and chairman of the Joint Chiefs of Staff, regarding “Humane Treatment of al Qaeda and Taliban Detainees,” February 7, 2002, http://www.pegc.us/archive/White_House/bush_memo_20020207_ed.pdf (accessed March 15, 2015). The Bush memo appears to have built upon a January 25, 2002, memo by Alberto Gonzales stating that in his opinion the “war on terror” was a “new paradigm [that] renders obsolete Geneva’s strict limitations on questioning of enemy prisoners and renders quaint some of its provisions... .” Memorandum from Alberto R. Gonzales to George W. Bush, President of the United States, January 25, 2002, <http://www2.gwu.edu/~nsarchiv/NSAEBB/NSAEBB127/02.01.25.pdf> (accessed March 15, 2015). In urging the president to declare that the Geneva Conventions did not apply to Taliban and Al-Qaeda detainees, Gonzales noted that such a declaration would “Substantially reduce[] the threat of domestic criminal prosecution under the War Crimes Act.” The War Crimes Act, discussed below, criminalizes any “grave breach” of the Geneva Conventions, which includes torture.

²²⁹ Memo by CIA General Counsel Scott W. Muller, “Memorandum for the Record: ‘Humane’ Treatment of CIA detainees,” February 12, 2003, <http://justsecurity.org/wp-content/uploads/2015/03/Exhibit-B-Bush-Policy-and-Legal-Directives-on-Interrogation.pdf> (accessed March 13, 2015)(hereinafter “Muller Memo for the Record.”).

Defense Department to CIA custody.²³⁰ It also mentioned conversations between Muller, Gonzales, Addington, Haynes, and Yoo, about a December 27, 2002 letter from Human Rights Watch raising concern about allegations of US abuse of detainees.²³¹

In the memo, Muller confirmed that on December 13, 2002, Yoo told him that the February 7, 2002 memo had been “deliberately limited” so it would only be binding on US Armed Forces, not the CIA.²³² Additionally, in two conversations John Bellinger told him that the types of interrogation techniques authorized by the attorney general had been “extensively discussed” and were “consistent with the President’s February 7, 2002 memo.” Muller also noted that at a January 13, 2003 meeting attended by Muller, Gonzales, Addington, Yoo, and Haynes about the Human Rights Watch December 27, 2002 letter, Addington, Gonzalez and Yoo confirmed that the president’s memo was only applicable to the armed forces.²³³

At another meeting three days later, on January 16, 2003, Muller said that there was “an arguable inconsistency between what the CIA was authorized to do and what at least some in the international community might expect in light of the Administration’s public statements about ‘humane treatment’ of detainees on and after the February memo.”²³⁴ At that meeting, attended by Muller, Rice, Rumsfeld, Haynes, Secretary of State Collin Powell, Cheney, and Tenet, the CIA’s past and ongoing use of approved interrogation techniques was “reaffirmed and in no way drawn into question,” according to the Muller memo.²³⁵

The reassurance provided to the CIA did not put the matter to rest. On June 25, 2003, Haynes wrote to Senator Patrick Leahy, in response to a letter Leahy wrote to Haynes with concerns about detainee treatment, saying that it is US policy to treat all detainees in a manner consistent with its obligations under the Convention against Torture as well as the

²³⁰ Muller Memo for the Record, p. 3.

²³¹ Senate Summary, p. 115, n. 685. See also Muller Memo for the Record, pp. 3-4. The letter they were discussing was: “United States: Reports of Torture of Al-Qaeda Suspects,” Human Rights Watch, December 27, 2002, <http://www.hrw.org/news/2002/12/26/united-states-reports-torture-al-qaeda-suspects> (accessed March 16, 2015).

²³² Cole, “‘The New Torture Files’: Declassified Memos Detail Roles of Bush White House and DOJ Officials Who Conspired to Approve Torture,” *Just Security*; See also Cole, “Torture: No One Said No,” *New York Review of Books*.

²³³ Muller Memo for the Record, pp. 3-4.

²³⁴ Muller Memo for the Record, p. 4.

²³⁵ Muller, February 12, 2003, Memo for the Record, p. 4.

Constitution's ban on cruel, inhuman or degrading treatment or punishment.²³⁶ On June 26, 2003, the White House issued a press release in support of International Support for Victims of Torture Day condemning "cruel" treatment of detainees; and on June 27, 2003, a White House spokesman was quoted as saying that the US government was treating detainees "humanely."²³⁷ All this prompted Tenet to write a letter to National Security Advisor Rice reminding her that the CIA had previously objected to White House statements that all US government detainees were being treated "humanely" and asked that the administration "reaffirm its commitment" to use of the CIA's enhanced interrogation program.²³⁸

These statements and actions were essentially admissions that, at minimum, the CIA was not treating detainees humanely. They also undermine the credibility of claims that these senior US officials were confident that the authorized techniques did not amount to torture. Additionally, they support the view that at least some officials consciously avoided asking whether the techniques were unlawful and may bring CIA General Counsel Muller, Rumsfeld, Haynes, and possibly Powell, into the ambit of the conspiracy.²³⁹ By January 9 2003, Navy General Counsel Alberto Mora had already informed Rumsfeld and Haynes that many of the same techniques were illegal and demanded orders approving them be rescinded (see above).²⁴⁰ Documentation from a later July 29, 2003 meeting show Bellinger suggesting, and others present—including Rice, Tenet, Muller, Ashcroft, Acting Assistant Attorney General OLC Patrick Philbin, Gonzales, and Cheney—appearing to agree to keep Haynes, Powell, and Bush out of meetings discussing details of the CIA program, which

²³⁶ Letter from William J. Haynes, II, general counsel to Department of Defense, to Senator Patrick Leahy, June 25, 2003, letter is available here, "Bush Administration Policy and Legal Directives on Interrogating Al-Qa-ida Detainees," Exhibit E, <http://ciasavedlives.com/bdr/bush.pdf> (accessed November 13, 2015).

²³⁷ Memorandum from George Tenet, CIA director, to National Security Advisor, Condoleezza Rice, (hereinafter "Tenet Memo for NSA"), July 3, 2003, <http://justsecurity.org/wp-content/uploads/2015/03/Exhibit-F-Bush-Policy-and-Legal-Directives-on-Interrogation.pdf> (accessed March 16, 2015), para. 2.

²³⁸ *Ibid*, para. 5.

²³⁹ The roles of Rumsfeld, Haynes, and Powell—present at the January 16, 2003 meeting where use of the CIA techniques was reaffirmed—should be investigated. However, the Senate Summary indicates that neither Powell nor Rumsfeld were briefed on the CIA's enhanced interrogation program prior to the use of the approved techniques on Abu Zubaydah and that as late as July 2003, Powell had still not been briefed for fear he would "blow his stack." Senate Summary, pp. 38, 118. There is substantial evidence that Rumsfeld is responsible for creating conditions for members of the armed forces to commit widespread torture and that he approved specific interrogation techniques that amounted to torture—though that may need to be analyzed separately from any role he may have played to further the aims of a conspiracy to torture as part of the CIA program. See *Getting Away with Torture*, pp. 75-84. Abuses by the US military are beyond the scope of this report.

²⁴⁰ SASC Report, p. 107. *Getting Away with Torture*, pp. 44-45.

was referred to in the documentation as “controversial.”²⁴¹ Rice, however, appears to have changed her mind and on August 4, 2003 had Bellinger call Muller and suggest that Powell and Haynes should be briefed before a specific date that is redacted from the memo.²⁴²

Reauthorization of the Torture Program

In November 2002, a detainee died in CIA custody and the CIA’s Office of Inspector General issued its scathing report on May 7, 2004 about both the use of techniques in an unauthorized manner, and the use of techniques that were never authorized. (“CIA OIG Report”).²⁴³ After the CIA OIG Report, CIA director Tenet suspended both the use of what were called “standard” interrogation techniques, as well as “enhanced interrogation techniques” pending a legal and policy review.²⁴⁴ The program was later reauthorized in a process that spanned the terms of three CIA directors: Tenet who resigned in June 2004, John McLaughlin who replaced him as acting CIA director until September 2004, and Porter Goss who took over from McLaughlin in September 2004.²⁴⁵ Daniel Levin, in 2004, and Steven Bradbury, in 2005, wrote memos that reauthorized the program, replacing the one that had been withdrawn by Goldsmith and drafting new ones that authorized additional techniques. These memos rejected the legal reasoning of the prior “Bybee Memos” but then authorized the same and even additional conduct using different legal reasoning.

Prior to re-authorization in 2005, according to the Senate Summary, the CIA provided the Justice Department with numerous descriptions of the interrogation techniques that were

²⁴¹ “Memorandum for the Record: Review of Interrogation Program on 29 July 2003,” dated August 5, 2003, <http://justsecurity.org/wp-content/uploads/2015/03/Exhibit-G-Bush-Policy-and-Legal-Directives-on-Interrogation.pdf> (accessed June 28, 2015), p. 5, para. 13.

²⁴² *Ibid.*, p. 6.

²⁴³ See generally, CIA OIG Report. On January 2, 2004 CIA Inspector General John Helgerson provided a draft of his final May 7, 2004 OIG report on the CIA’s detention and interrogation program to the CIA for comment that had already alerted the CIA to many of his concerns. See Senate Summary, p. 190.

²⁴⁴ Senate Summary, pp. 413-414. The difference between “standard” and “enhanced” interrogation techniques were first explained in a memo issued by the CIA director Tenet on January 28, 2003. (See CIA OIG Report, Appendix E). The Guidance was issued in response to the death of CIA detainee Gul Rahman. (See Senate Summary, p. 62-63). The memo purportedly formalized existing practice for obtaining required approvals from CIA headquarters prior to use of the techniques. (See CIA OIG Report, p. 6). In that guidance, “standard” interrogation techniques were defined as those “that *do not* incorporate physical or substantial psychological pressure.” (See CIA OIG Report, Appendix E (emphasis in the original)). The guidance said they “include, but are not limited to, all lawful forms of questioning employed by US law enforcement and military interrogation personnel.” Some examples included sleep deprivation up to 72 hours, isolation, loud music, and diapering generally not to exceed 72 hours.

²⁴⁵ William Branigin, “CIA Director Tenet Resigns,” *Washington Post*, June 3, 2004, <http://www.washingtonpost.com/wp-dyn/articles/A12296-2004Jun3.html> (accessed April 30, 2015); Barton Gellman and Dafna Linzer, “Top Counterterrorism Officer Removed Amid Turmoil at CIA,” *Washington Post*, February 7, 2006 http://www.washingtonpost.com/wp-dyn/content/article/2006/02/07/AR2006020700016_2.html (accessed April 30, 2015).

false and inconsistent with how the CIA had actually been applying them, the physical and psychological impact of the techniques on detainees, the threat posed by those to whom the techniques were being applied, and their degree of effectiveness.²⁴⁶ For example, the CIA represented that standing sleep deprivation would be discontinued if it resulted in significant swelling of the lower extremities (edema) but in practice this technique “was repeatedly not stopped when edema occurred.”²⁴⁷ Additionally, the CIA provided false information about the use of light and cold temperatures on detainees, the claim that interrogations would stop when detainees experienced hallucinations, and a number of other matters.²⁴⁸ The Senate Summary does not clearly identify who exactly is responsible for supplying this false information, identifying a number of CIA sources, and indicates that more information is available in the still classified sections of the complete report.

There is also information in the Senate Summary that Acting Assistant Attorney General for OLC Steven Bradbury was looking for statements from the CIA that he could use to justify the techniques in his new memo. For example, just days before Bradbury issued new memos on May 10, 2005 re-authorizing the program, he sent a letter to the CIA asking if medical monitoring and other safeguards in place “will effectively avoid severe physical pain or suffering for detainees.”²⁴⁹ The CIA’s Office of Medical Services (OMS) had expressed discomfort with these types of questions just a few weeks earlier when they received a draft of the OLC authorizing memo for review:

Simply put, OMS is not in the business of saying what is acceptable in causing discomfort to other human beings, and will not take on that burden.... OMS did not review or vet these techniques prior to their introduction, but rather came into this program with the understanding of your office and DOJ [Department of Justice] that they were already determined as legal, permitted and safe. We see this current iteration [of the OLC memorandum] as a reversal of that sequence, and a relocation of those decisions to OMS. If this is the case, that OMS has now the responsibility for determining a procedure's

²⁴⁶ Senate Summary, pp. 409-431.

²⁴⁷ Senate Summary, p. 422.

²⁴⁸ Ibid.

²⁴⁹ Senate Summary, p. 420.

legality through its determination of safety, then we will need to review all procedures in that light given this new responsibility.²⁵⁰

Nevertheless, OMS later responded to Bradbury that the CIA's program "has effectively avoided severe physical pain and suffering, and should continue to do so. Application of the thirteen techniques has not to date resulted in any severe or permanent physical injury (or any injury other than transient bruising), and we do not expect this to change."²⁵¹

CIA officials who supplied the false information can be considered to have joined the conspiracy. The overt acts are that they supplied the false facts, were aware of the program's unlawful aims, the infliction of severe pain and suffering, and did so with the intent of the conspiracy to torture succeeding. Similarly, by drafting and issuing new legal memos that reauthorized the same and even additional "enhanced interrogation techniques," especially in light of the controversy around them and problems with the program reported by the CIA OIG, both Levin and Bradbury can be seen as having undertaken overt acts—drafting of the new memos—with knowledge of the conspiracy's unlawful aims and with the intent that the use of these techniques continue and thus that the conspiracy succeed.

Evidence against Other Officials in Connection with the Conspiracy

Other individuals who—due to their positions or reported actions—should be included in an investigation in connection with the conspiracy include:

- Jose Rodriguez, Cofer Black's successor, who oversaw operation of the CIA's program from May 2002-November 2004 and was responsible for ordering the destruction of 92 videotapes documenting the CIA's use of "enhanced interrogation techniques," which included waterboarding sessions, over the objections of senior officials at the White House and the CIA, as well as Congress.²⁵² Later in his memoirs, Rodriguez describes his order to destroy the tapes as "just getting rid of some ugly visuals."²⁵³

²⁵⁰ Senate Summary, p. 420, n. 2361.

²⁵¹ Senate Summary, p. 421.

²⁵² Peter Finn and Julie Tate, "2005 destruction of interrogation tapes caused concern at CIA, e-mails show," *Washington Post*, April 16, 2010, <http://www.washingtonpost.com/wp-dyn/content/article/2010/04/15/AR2010041505854.html> (accessed April 6, 2015); Peter Taylor, "'Vomiting and screaming' in destroyed waterboarding tapes," BBC, May 9, 2012, <http://www.bbc.com/news/world-us-canada-17990955> (accessed April 6, 2015).

²⁵³ Adam Goldman and Matt Apuzzo, "Jose Rodriguez, Ex-CIA Officer, Defends Destroying Waterboarding Videos In 'Hard Measures' Book," *Huffington Post*, April 24, 2012, http://www.huffingtonpost.com/2012/04/24/jose-rodriguez-cia-hard-measures-book_n_1450416.html (accessed April 13, 2015).

- The CIA's current deputy general counsel for operations, Robert EATINGER, who is reportedly mentioned by name more than 1,600 times in the Senate's full report, though his name did not appear in the Senate Summary.²⁵⁴ EATINGER was a lawyer in the CIA's Counterterrorism Center when the center managed and carried out the detention and interrogation program, and from mid-2004 until official termination of the program in January 2009, he was the unit's chief lawyer.²⁵⁵ He reportedly provided legal advice that RODRIGUEZ had legal authority to destroy the tapes and that the destruction would violate no laws.²⁵⁶ He is also accused of providing inaccurate information to the OLC about the CIA program upon which the OLC relied when issuing authorizations for CIA action.²⁵⁷
- Cofer Black, head of the CIA's counterterrorism center from June 1999 until the end of 2002, appeared to play a key role in implementing the program as well, though his exact role is not necessarily clear from the public record. In October 2008, CIA Director Tenet delegated responsibility to him to manage the capture and detention authorities provided in the MON.²⁵⁸ Black famously said during testimony before Congress on September 26, 2002: "[T]here was 'before' 9/11 and 'after' 9/11. After 9/11 the gloves come off."²⁵⁹
- Someone identified as "CTC legal" in the Senate Summary. "CTC Legal" first proposed to the CIA in April 2002 that they use James Mitchell as a CIA consultant in

²⁵⁴ "Senator Statement on Intel Committee's CIA Detention, Interrogation Report," March 11, 2014, <http://www.feinstein.senate.gov/public/index.cfm/2014/3/feinstein-statement-on-intelligence-committee-s-cia-detention-interrogation-report> (accessed April 6, 2015) (hereinafter "Senator Feinstein's March 11, 2014 Senate Floor Statement"); Ken Dilanian, "CIA lawyer Robert EATINGER is no stranger to controversy," *Los Angeles Times*, March 12, 2004, <http://articles.latimes.com/2014/mar/12/nation/la-na-cia-lawyer-20140313> (accessed October 21, 2015).

²⁵⁵ Senator Feinstein's March 11, 2014 Senate Floor Statement.

²⁵⁶ Mark Mazzetti and Scott Shane, "Bush Lawyers Discussed Fate of CIA Tapes," *New York Times*, December 19, 2007, http://www.nytimes.com/2007/12/19/washington/19intel.html?pagewanted=all&_r=0 (accessed October 19, 2015).

²⁵⁷ Senator Feinstein's March 11, 2014 Senate Floor Statement; see also Complaint from Katherine Hawkins, National Security Fellow at OpenTheGovernment.org to John P. Fitzpatrick, Director of the Information Security Oversight Office, September 15, 2015, Re: Wrongful classification of information regarding CIA torture, in violation of Executive, http://www.openthegovernment.org/sites/default/files/ISOO_Complaint_CIA_torture.pdf, (accessed October 19, 2015), pp. 11-13 (hereinafter "OpenTheGovernment.org Complaint"), which connects Robert EATINGER to several pseudonyms in the Senate Summary and identifies him as having played a major role in supplying inaccurate information to the OLC.

²⁵⁸ Senate Summary, p. 13.

²⁵⁹ Testimony of Cofer Black, former chief, DCI's Counterterrorism Center, CIA, Before the Senate Select Committee on Intelligence and House of Representatives Permanent Select Committee on Intelligence, "Joint Inquiry Into Intelligence Community Activities Before and After the Terrorist Attacks of September 11, 2001," 107th Congress, September 26, 2002, http://fas.org:8080/irp/congress/2002_hr/092602black.html (accessed April 6, 2015).

interrogations and the use of aggressive interrogation techniques.²⁶⁰ “CTC Legal” also was the author of a July 8, 2002 letter that acknowledged the illegality of the CIA’s proposed enhanced interrogation techniques.²⁶¹ This individual was part of a CIA legal team present at the July 13, 2002 meeting, which included Rizzo and other unnamed CIA lawyers, who proposed the use of “enhanced interrogation techniques” and sought a declination from the Justice Department’s Criminal Division.²⁶² “CTC Legal” also drafted a memo in June 2003 when the CIA was looking at reaffirmation of the CIA program stating that one of the August 1, 2002 memos provided “safe harbor” for the CIA’s use of “enhanced interrogation techniques.”²⁶³ “CTC Legal” was also present, along with Alfreda Bikowski, during “aggressive” interrogations of Abu Zubaydah that included the use of waterboarding.²⁶⁴

OLC Memos as Evidence of Conspiracy and Intent to Torture

Beyond CIA efforts to obtain what would be preemptive immunity from prosecution for using torture, the strained legal reasoning of the “Bybee Memos” themselves also suggests that those involved knew they were creating “authorization” as a cover for what would otherwise almost certainly be deemed illegal acts.

The memos themselves were deeply flawed from a legal perspective and have been widely discredited.²⁶⁵ The Bybee I Memo invented definitional requirements for torture that went far beyond any existing standard by, for example, drawing on irrelevant health benefits statutes to argue that “physical pain amounting to torture must be equivalent in intensity to the pain accompanying serious physical injury, such as organ failure, impairment of bodily function, or even death.”²⁶⁶ Mental pain or suffering would only

²⁶⁰ Senate Summary, p. 26; see also “OpenTheGovernment Complaint,” which connects Jonathan Fredman, Chief Legal Counsel for the CIA’s Counterterrorism Center on September 11, 2004 until April 2004 with the pseudonym “CTC Legal” in the Senate Summary, pp. 7-10.

²⁶¹ Senate Summary, p. 33.

²⁶² Senate Summary, p. 33.

²⁶³ Senate Summary, p. 118, n. 690.

²⁶⁴ Senate Summary, p. 43, n. 197.

²⁶⁵ For example, nearly 130 prominent lawyers, retired judges and a former director of the FBI released a statement after the first of the memos was leaked to the press condemning their use. “The position taken by the government lawyers in these legal memoranda amount to counseling a client as to how to get away with violating the law,” wrote one of the signatories. The memos “circumvent long established and universally acknowledged principles of law and common decency,” the statement said. Scott Higham, “Law Experts Condemn U.S. Memos On Torture,” *Washington Post*, August 5, 2004, <http://www.washingtonpost.com/wp-dyn/articles/A41189-2004Aug4.html> (accessed January 28, 2015).

²⁶⁶ Bybee I Memo, p. 1.

amount to torture if it results in “significant psychological harm of significant duration, e.g., lasting for months or even years.”²⁶⁷

The Bybee I Memo advised that the claimed specific intent requirement in the Torture Statute could be negated by a good faith belief that the acts undertaken would not cause prolonged mental harm. A defendant in a criminal case could demonstrate this good faith belief by showing for example that he surveyed the professional literature, consulted with experts, or reviewed evidence gained from past experience.²⁶⁸ The memo also advised that if an interrogator were to harm a detainee during use of “enhanced interrogation techniques,” he would be doing so to prevent further attacks on the US and therefore would be justified by the Commander-in-Chief’s constitutional authority to prevent the nation from attack.²⁶⁹ The assertion ignores well-established US Supreme Court precedent making clear that the executive branch does not have unbridled authority in the conduct foreign affairs—it is bound by congressional statutes and judicial decisions.²⁷⁰ Torture is prohibited by US and international human rights and humanitarian law at all times and for all reasons. There is no exception for war or public emergencies.²⁷¹

The Justice Department withdrew the Bybee I Memo in June 2004, in the wake of the Abu Ghraib scandal and just days after its contents were leaked to the media.²⁷² Jack Goldsmith, who replaced Yoo, headed the OLC from October 2003 to June 2004, and was largely responsible for getting the Bybee I Memo withdrawn, said the memo was “riddled with error” and a “one-sided effort to eliminate any hurdles posed by the torture law.”²⁷³ On June 4, 2004, CIA Director George Tenet suspended the use of both “enhanced” and

²⁶⁷ Bybee I Memo, p. 1.

²⁶⁸ Bybee I Memo, p. 8.

²⁶⁹ Bybee I Memo, p. 46.

²⁷⁰ *Youngstown Sheet & Tube Co. v. Sawyer*, 343 U.S. 579, 587 (1952). As Justice Robert H. Jackson stated in a concurring opinion, “[the president] has no monopoly of ‘war powers,’ whatever they are. While Congress cannot deprive the President of the command of the army and navy, only Congress can provide him an army or navy to command. It is also empowered to make rules for the ‘Government and Regulation of land and naval Forces,’ by which it may to some unknown extent impinge upon even command functions.”). *Ibid.*, pp. 643-44. See also Kathleen Clark and Julie Mertus, “Torturing the Law,” *Washington Post*, June 20, 2004, <http://www.washingtonpost.com/wp-dyn/articles/A54025-2004Jun19.html> (accessed April 6, 2015).

²⁷¹ Convention against Torture, art. 2(2).

²⁷² See OPR Report, p. 121; Priest and Smith, “Memo Offered Justification for Use of Torture,” *Washington Post*; Priest, “Justice Dept. Memo Says Torture ‘May Be Justified,’” *Washington Post*.

²⁷³ OPR, investigation p. 160.

“standard” techniques pending policy and legal review.²⁷⁴ New legal memos issued later to replace the Bybee I Memo acknowledged that the prior legal reasoning was wrong.²⁷⁵ According to the replacement memo, “Because the discussion concerning the President’s Commander-in-Chief power and potential defenses to liability was—and remains—unnecessary, it has been eliminated... Consideration of the bounds of any such authority would be ‘inconsistent’ with the President’s unequivocal directive not to engage in torture.”²⁷⁶

Specifically concerning the claim that harm to a detainee might be justified in order to prevent the nation from an attack, the replacement memo stated that “[t]here is no exception under the statute permitting torture to be used for a ‘good reason.’ Thus, a defendant’s motive (to protect national security, for example) is not relevant to the question of whether he acted with the requisite specific intent under the statute.”²⁷⁷ On the level of pain required to meet the definition of torture, the replacement memo reads: “[W]e do not believe Congress intended only to reach conduct involving excruciating and agonizing pain or suffering. ... Thus, we do not agree with the August 2002 Memorandum.”²⁷⁸

Though the replacement memos—one issued on December 30, 2004²⁷⁹ (“Levin Replacement Memo”) and several others issued in 2005²⁸⁰ (“Bradbury Memos”)—attempt to apply new legal reasoning, they continued to authorize the same and even additional conduct that amounts to torture or other ill-treatment.²⁸¹ For example, they continued to authorize waterboarding. Waterboarding is essentially the same as other forms of water

²⁷⁴ SSCI, pp. 413-414. See discussion of the difference between “standard” and “enhanced” interrogation techniques in section “Reauthorization of the torture program” in note 244 above. The difference between “enhanced” and “standard” interrogation techniques are discussed in the footnotes for this report’s chapter Evidence of Conspiracy to Torture: Reauthorization of the Torture Program.

²⁷⁵ For example, “...we disagree with statements in the August 2002 Memorandum limiting ‘severe’ pain under the statute to ‘excruciating and agonizing’ pain ‘equivalent in intensity to the pain accompanying serious physical injury, such as organ failure, impairment of bodily function, or even death.’” Levin Replacement Memo, p. 2, <https://www.aclu.org/files/torturefoia/released/o82409/olcremand/2004olc96.pdf> (accessed January 29, 2015).

²⁷⁶ Levin Replacement Memo, p. 2.

²⁷⁷ Levin Replacement Memo, p. 17.

²⁷⁸ Levin Replacement Memo, p. 8 and p. 8, n. 17.

²⁷⁹ Levin Replacement Memo.

²⁸⁰ Acting OLC head Steven Bradbury issued three opinions to CIA general counsel John Rizzo providing further guidance and authorization for the CIA’s “enhanced interrogation techniques” in May 2005. The three memos are discussed in the first section of the Background chapter of this report.

²⁸¹ Scott Shane and David Johnston, “U.S. Lawyers Agreed on Legality of Brutal Tactic,” *New York Times*, June 6, 2009, http://www.nytimes.com/2009/06/07/us/politics/07lawyers.html?pagewanted=all&_r=0 (accessed April 22, 2015).

torture that have been prosecuted in US courts,²⁸² as well as military courts and tribunals in the past.²⁸³ President Barack Obama, former Attorney General Eric Holder, Attorney General Loretta Lynch, have all called waterboarding torture.²⁸⁴ “The position taken by the government lawyers in these legal memoranda amount to counseling a client as to how to get away with violating the law,” said John Gibbons, former chief judge of the US Court of Appeals for the Third Circuit, after the memos had been released.²⁸⁵

The language used in the 2005 replacement memos themselves, drafted by then Deputy Assistant Attorney General Steven Bradbury, acknowledges the severity and harshness of the techniques while at the same time purporting to authorize them. One memo states that use of the waterboard does pose a “small risk” of certain “potentially significant medical problems” such as vomiting and aspirating emesis, aspirating water—which might lead to pneumonia—or “spasms in the larynx that would prevent [a detainee] from breathing.” In the event of such spasms, “a qualified physician would be present to intervene and perform a tracheotomy if necessary.”²⁸⁶ The memo authorizes up to 180 hours (7.5 days) of sleep deprivation, which was often done by forcing detainees to stand nude and diapered during that period.²⁸⁷ Though the memo acknowledges this may cause “edema,” (swelling

²⁸² A Texas sheriff and two of his deputies who tried to argue they were just following orders were prosecuted and convicted in federal court in 1983 for torturing six detainees. The method of torture was to handcuff the detainees “to a table or chair with the face wrapped tightly with a towel. The head would be pulled back, they said, and water would be poured over the towel until, fearing drowning, they would talk.” “Ex-Sheriff Given 10-Year Sentence,” *New York Times*, October 27, 1983, <http://www.nytimes.com/1983/10/27/us/ex-sheriff-given-10-year-sentence.html> (accessed February 3, 2015). The judge sentenced the sheriff to 10 years in prison and fined him \$12,000. He also sentenced one of the sheriff’s deputies two years plus a three-year suspended sentence, and another to seven years, but he would only serve four. At the sentencing, the judge said that law enforcement had been allowed to fall into “the hands of a bunch of thugs” and that “the operation down there would embarrass the dictator of a country.” See also *United States v. Lee*, 744 F.2d 1124 (5th Cir. 1984) affirming the conviction though the opinion was limited to a procedural matter concerning refusal to grant a severance.

²⁸³ See *Getting Away with Torture*, pp. 54-56 listing several instances of US courts and tribunals finding waterboarding and other forms of water abuse constitute torture.

²⁸⁴ David Stout, “Holder Tells Senators Waterboarding Is Torture,” *New York Times*, January 15, 2009, http://www.nytimes.com/2009/01/16/us/politics/16holdercnd.html?scp=3&sq=Eric%20Holder%20torture&st=cse&_r=0 (accessed February 6, 2015); Video: Loretta Lynch: “Waterboarding is torture,” *Politico*, January 28, 2015, <http://www.politico.com/multimedia/video/2015/01/loretta-lynch-waterboarding-is-torture.html> (accessed February 6, 2015); Ewen MacAskill, “Obama: ‘I believe waterboarding was torture, and it was a mistake,’” *The Guardian*, April 29, 2009, <http://www.theguardian.com/world/2009/apr/30/obama-waterboarding-mistake> (accessed February 6, 2015).

²⁸⁵ Scott Higham, “Law Experts Condemn U.S. Memos On Torture,” *Washington Post*, August 5, 2004, <http://www.washingtonpost.com/wp-dyn/articles/A41189-2004Aug4.html> (accessed March 31, 2015).

²⁸⁶ Memorandum from Steven Bradbury, deputy assistant attorney general, to John Rizzo, senior deputy general counsel for the CIA, May 10, 2005, (hereinafter “Bradbury Combined Techniques Memo,”) <http://fas.org/irp/agency/doj/olc/techniques.pdf> (access November 13, 2015), p. 14.

²⁸⁷ Bradbury Combined Techniques Memo, p. 10.

caused by fluid gathering in the tissues)²⁸⁸ it suggests that in this case, the detainee can be restrained in a way that will continue to deprive him of sleep while lying prone until the condition subsides and then resume standing.²⁸⁹ Also, though individuals will likely experience “some discomfort,” “distress” and “fatigue,” and this can also cause “impairment to coordinated body movement, difficulty with speech, nausea, and blurred vision,” this would not amount to torture so long as the individuals are monitored and their diapers checked regularly for skin irritation, the memo read.²⁹⁰ It also may result in hallucinations, the memo reads, which could result in “profound” disruption of the senses and thus be defined as torture, but because it would not be “calculated” to achieve that result, it would not satisfy the requirements of the torture statute.²⁹¹

Further, a separate memo for the first time authorized use of the techniques in combination (combinations of practices such as diapering, nudity, walling, stress positions, and water dousing, among others).²⁹² Some of these specific techniques have been referred to as amounting to torture by US courts.²⁹³ The US has also denounced many of these techniques

²⁸⁸ Definition of “edema,” *PubmedMed Health*, <http://www.ncbi.nlm.nih.gov/pubmedhealth/PMHT0022960/> (accessed February 7, 2015).

²⁸⁹ Bradbury Combined Techniques Memo, p. 10.

²⁹⁰ Bradbury Combined Techniques Memo, pp. 37-38

²⁹¹ Bradbury Combined Techniques Memo, p. 39.

²⁹² Bradbury Combined Techniques Memo.

²⁹³ Most cases analyzing whether past conduct amounted to torture are civil, and courts tend to look at a course of conduct rather than whether each individual technique to which a plaintiff was subjected amounted to torture. Some of the specific cases with relevant conduct include: *In re Estate of Marcos Human Rights Litig.*, 910 F. Supp. 1460, 1463 (D. Haw. 1995) (a class action in which approximately 10,000 plaintiffs sued the Estate of Ferdinand E. Marcos, the former president of the Philippines, for torture, enforced disappearance, and summary executions. Among the many forms of torture for which the estate was found liable was a technique called the “water cure” where a cloth was placed over the detainee’s mouth and nose, and water poured over it producing a drowning sensation. Relief was granted under the Torture Victims Protection Act (TVPA)); *Hilao v. Marcos*, 103 F.3d 789, 790 (9th Cir. 1996) (in which two plaintiffs who did not take part in the class action (above) sued the Marcos’ estate. One was interrogated, blindfolded, and severely beaten. Also, while shackled to his cot, a towel was placed over his nose and mouth and, for six hours, interrogators poured water down his nostrils so that he felt as though he were drowning. He then spent more than eight years in detention, five of them in solitary confinement. Another plaintiff was held in incommunicado detention, repeatedly interrogated, subjected to mock executions, and threatened with death. Both plaintiffs were found to have been subjected to torture and were granted relief under the Alien Tort Claims Act and the TVPA); *Daliberti v. Republic of Iraq*, 146 F. Supp. 2d 19 (finding that holding one plaintiff at gunpoint, threatening to injure him physically if he did not confess to espionage or otherwise provide information, and incarcerating him in a room with no bed, window, light, electricity, water, toilet or adequate access to sanitary facilities, constituted torture. Also finding that placing loaded guns to plaintiffs’ heads, depriving them of medical treatment, and incarcerating them in an environment without adequate toilet facilities constituted torture); See also note 282 above in this section describing a case where a Texas sheriff and two of his deputies who tried to argue they were just following orders were prosecuted and convicted in federal court in 1983 for torturing six detainees. *cf. Padilla v. Yoo*, 678 F.3d 748, 767, n. 15 (9th Cir. Cal. 2012) (In deciding whether respondents, including John Yoo, were entitled to qualified immunity in a civil case brought by a U.S. citizen for violation of his constitutional rights in military detention, the court assumed without deciding that treatment even less severe than some of the harshest of the approved CIA “enhanced interrogation techniques” amounted to torture but also that whether Padilla’s abuses amounted to torture was “not beyond debate” at the time the OLC memos were issued. The opinion states—without many details

as torture when practiced by other countries.²⁹⁴ Additionally, the Army Field Manual on Intelligence Interrogation in effect when the OLC memos were issued, prohibits torture and lists as an example of physical torture: “forcing an individual to stand, sit or kneel in abnormal positions for prolonged periods of time,” and “food deprivation.”²⁹⁵ It also lists “abnormal sleep deprivation,” as an example of mental torture.²⁹⁶

Finally, the new memos were issued only after many of the most egregious abuses took place.²⁹⁷ Even if they had been based on sound legal analysis, they could not have provided retroactive authorization.

Evidence of Torture: Conduct Beyond What Was Authorized

Both international human rights and humanitarian law prohibit torture and other forms of ill-treatment, standards that CIA program practices violated. But even if one were to discount those international requirements, the CIA program went beyond the techniques that were authorized and the claimed protections from legal liability set out in the Torture Memos.²⁹⁸

that would allow his treatment to be properly compared to what detainees in the CIA program were subjected to—that Padilla endured prolonged isolation; sensory deprivation, and “stress” positions, among other things).

²⁹⁴ Human Rights Watch, “USA and Torture: A History of Hypocrisy,” December 9, 2014, <http://www.hrw.org/news/2014/12/09/usa-and-torture-history-hypocrisy> (accessed February 2, 2014); James Ross, “Details of how U.S. rebuked foreign regimes while using same torture methods,” Reuters, December 11, 2014 <http://blogs.reuters.com/great-debate/2014/12/11/us-called-out-foreign-regimes-as-cia-used-same-torture-methods/> (accessed November 7, 2015); See also *Getting Away With Torture*, p. 57.

²⁹⁵ Department of the Army, Field Manual 34-52: Intelligence Interrogation, September 28, 1992, <http://www.fas.org/irp/doddir/army/fm34-52.pdf> (accessed February 2, 2015), Chapter 1, p. 8. (However, this language was removed in 2006. See e.g. Human Rights First, “The U.S. Army Field Manual on Interrogation: A Strong Document in Need of Careful Revision,” https://www.humanrightsfirst.org/wp-content/uploads/pdf/Army_Field_Manual.pdf (accessed May 8, 2015), p. 2.

²⁹⁶ Department of the Army, Field Manual 34-52, p. 2.

²⁹⁷ Senate Summary, p. 96. (While the CIA held detainees from 2002 until 2008, early 2003 was the most active period of the program. Of the 119 detainees identified by the Senate Summary as being held by the CIA, 53 were brought into custody in early 2003. Of the 39 detainees found to have been subjected to “enhanced interrogation techniques,” 17 were subjected to them between January 2003 and August 2003, primarily at detention sites identified in the Senate Summary as Cobalt and Blue, both of which are believed to have been in Afghanistan); see also Adam Goldman and Julie Tate, “Decoding the secret black sites on the Senate’s report on the CIA interrogation program,” *Washington Post*, December 9, 2014, <http://www.washingtonpost.com/blogs/worldviews/wp/2014/12/09/decoding-the-secret-black-sites-on-the-senates-report-on-the-cia-interrogation-program/> (accessed February 1, 2015).

²⁹⁸ The CIA admits that CIA officers and contractors used techniques that went beyond what were authorized and that they detained individuals who never should have been. But it says those responsible, 16 of them, have been administratively sanctioned and it would not be practical or productive to revisit these practices. See CIA Response, paras. 29 and 30, https://www.cia.gov/library/reports/CIA_June2013_Response_to_the_SSCI_Study_on_the_Former_Detention_and_Interrogation_Program.pdf (accessed February 7, 2015).

First, the CIA used enhanced interrogation techniques on Abu Zubaydah before OLC issued the Bybee Memos. Documents released in April 2010 in response to Freedom of Information Act requests from the ACLU,²⁹⁹ revealed that the CIA subjected Abu Zubaydah to sleep deprivation beyond 48 hours at some point after his capture but before April 2002.³⁰⁰ The CIA claims it did this only after “consulting” with “NSC and DOJ” and getting approval to use sleep deprivation for between 24-48 hours. How many hours of sleep deprivation beyond 48 Abu Zubaydah was subjected to, or how many times during this period, is not made clear from the document, but it does say that due to a “misunderstanding” the 24 to 48-hour time frame was exceeded.³⁰¹

Additionally, the Bybee II Memo to Rizzo only approved the use of specific techniques on Zubaydah for certain purposes and under certain conditions.³⁰² “If these facts change, this advice would not necessarily apply,” the memo read.³⁰³ The Senate Summary is filled with examples of changed facts. For one, the CIA applied the authorizations for Zubaydah to other detainees without seeking further formal approval.³⁰⁴ After the Senate Summary was released, John Yoo said that the initial OLC authorization for the use of “enhanced interrogation techniques” was meant to only apply to Abu Zubaydah.³⁰⁵ It was not until almost a year later, on July 29, 2003, that CIA records indicate, according to the Senate Summary, that the attorney general stated at a meeting that the legal principles of the August 1, 2002 memorandum applied to other detainees.³⁰⁶

²⁹⁹ American Civil Liberties Union, “Torture Documents Released 4/15/2010,” <https://www.aclu.org/torture-documents-released-4152010> (accessed August 13, 2015). See also “How Abu Zubaydah’s Sleep Deprivation Got Out of Control,” *emptywheel*, April 16, 2015, <https://www.emptywheel.net/2010/04/16/how-abu-zubaydahs-sleep-deprivation-got-out-of-control/> (directing readers to pages 113-114 of the massive set of documents released where Abu Zubaydah’s sleep deprivation prior to the OLC memos being issued is documented) (accessed August 13, 2015).

³⁰⁰ American Civil Liberties Union, “The Torture Documents Released 4/15/2010,” https://www.aclu.org/sites/default/files/pdfs/natsec/20100415_CIArelease_destructionoftapes.pdf (accessed November 13, 2015), pp. 113-114.

³⁰¹ *Ibid.*

³⁰² Bybee II Memo, p. 1.

³⁰³ Bybee II Memo, p. 1.

³⁰⁴ Senate Summary, p. 411; See OPR Report, p. 124, n. 95.

³⁰⁵ Dan Lamothe, “Former Bush lawyer: U.S. did not consider cumulative effects of ‘enhanced interrogation,’” *Washington Post*, December 12, 2014, <http://www.washingtonpost.com/news/checkpoint/wp/2014/12/12/former-bush-lawyer-u-s-did-not-consider-cumulative-effects-of-enhanced-interrogation/> (accessed November 13, 2015).

³⁰⁶ Senate Summary, p. 411; OPR Report, pp. 116-117. Apparently one basis for the attorney general’s comments at this meeting was a set of “Bullet Points” that the OPR report describes as having generated a “controversy.” See OPR Report, p. 114. The origins of the “Bullet Points” appear to be the CIA. They were sent to Yoo on April 2003 by Muller, reworked by an unnamed OLC attorney and Yoo, and then sent back to the CIA. OPR Report, pp. 100-01. According to the unnamed attorney, they were intended to provide a summary to the CIA OIG John Helgerson—who was working on a report evaluating the CIA’s detention and interrogation program—of the legal advice the OLC had provided to the CIA about the legality of the detention and interrogation program. They

After Jack Goldsmith took over as head of the OLC after Yoo's departure, he read the CIA OIG Report and learned that the CIA had been using the Bybee II memo to justify the use of "enhanced interrogation techniques" on other detainees. He subsequently wrote a letter to the CIA admonishing them for this practice. "Our initial review of the Inspector General's Report," Goldsmith wrote to Muller on May 27, 2004, "raises the possibility that, at least in some instances and particularly early in the program, the actual practice may not have been congruent with all of these assumptions and limitations [in the August 1, 2002 memo to Rizzo]."³⁰⁷ While he acknowledged that at some point it appeared that the OLC had agreed that the legal principles articulated in the August 1, 2002 memo could apply to other detainees, he "strongly recommended" that the CIA suspend use of waterboarding and review steps taken to ensure that in actual practice any use of CIA techniques "adheres closely to the assumptions and limitations in the August 2002 opinion."³⁰⁸ After Goldsmith's resignation from the OLC, subsequent OLC staff appear to have produced individualized memoranda for detainees subject to CIA "enhanced interrogation techniques."³⁰⁹

were also meant to "demonstrate that the OLC had already weighed in." OPR Report, p. 101. They appear to have been prepared sometime in June 2003. Muller said they "served as a basis for the 'Legal Authorities' briefing slide used at the July 29, 2003 meeting," which was also attended by Cheney, Rice, Patrick Philbin, the Director of National Intelligence, and others. OPR Report, p. 116. On March 2, 2004 Goldsmith said he first received a copy of the "Bullet Points." OPR Report, p. 114. They were attached to a letter he received from Muller on that day asking him to reaffirm the legal advice he claimed OLC had given to the CIA regarding the detention and interrogation program. Specifically, Muller wanted Goldsmith to reaffirm the August 1, 2002 Yoo letter, the Bybee Memos, and the "Bullet Points." OPR Report, p. 114. Goldsmith was concerned by the "Bullet Points" because they appeared to be a CIA document, contained no legal analysis or any indication that OLC had reviewed them. OPR Report, p. 114. After this, in late May 2004, the CIA Office of General Counsel sent a copy of the final May 7, 2004 CIA OIG report to OLC. The report included descriptions of the legal advice provided to the CIA by OLC and included copies of the "Bullet Points" as appendices. On May 25, 2004, Goldsmith wrote to CIA IG John Helgerson asking for an opportunity to provide comments on the report's discussion of the OLC's legal advice before it was sent to Congress. Two days later, on May 27, 2004, Goldsmith wrote to Muller and advised him that the report "raised concerns about certain aspects of interrogation practice." On June 9, Goldsmith called Yoo to get clarification on the "Bullet Points." OPR Report, p. 116. Yoo told Goldsmith that the OLC had not produced the "Bullet Points" and that they did not constitute the official views of the OLC. OPR Report, p. 116. On June 10, 2004, Goldsmith wrote to Muller that the OLC would not reaffirm the "Bullet Points" which "did not and do not represent an opinion or a statement of the views of this Office." OPR Report, p. 16. Though apparently there had been some discussion about the CIA and the OLC submitting a joint letter to Helgerson, in the end because the two offices had different views about the significance of the Bullet Points, they would not be joint signatories to the letter. OPR Report, p. 116. Goldsmith submitted his comments to Helgerson on June 18, 2004. In those comments he asked that two areas of "ambiguity or mistaken characterizations" in the report be corrected. First, that the attorney general's comments at the July 29, 2003 meeting on the "expanded use" of "enhanced interrogation techniques" were intended to refer to the use of approved techniques on other detainees in addition to Abu Zubaydah, not the use of new techniques. Second, he said that the "Bullet Points" "were not and are not an opinion from OLC or formal statement of views." OPR Report, p. 117.

³⁰⁷ "Letter from head of the Justice Department Office of Legal Counsel Jack Goldsmith to General Counsel of the CIA Scott Muller," May 27, 2004, <http://www.justice.gov/sites/default/files/olc/legacy/2009/08/24/memo-muller2004.pdf> (accessed August 23, 2015).

³⁰⁸ *Ibid.*

³⁰⁹ See Bradbury Combined Techniques Memo, p. 4. See also e.g. Letter from Daniel Levin to John Rizzo, September 6, 2004, <http://www.justice.gov/sites/default/files/olc/legacy/2009/08/24/memo-rizzo2004-4.pdf> (accessed August 26, 2015); and documents 70, 74, 79, 85, 88, 95 described in a Vaughn Index (a document that agencies prepare in FOIA litigation to justify

In addition, the Senate Summary and other documents show that the use of the interrogation techniques specifically in combination does not appear to have been specifically approved by OLC memo on any detainee other than Abu Zubaydah, and even then in a cursory fashion, until May 10, 2005.³¹⁰ Failure to have done this combination analysis at the outset is one of many a serious flaws of the initial August 1, 2002 memos. For one, US courts tend to look at a course of conduct rather than each individual method of abuse when determining whether it amounts to torture.³¹¹ But for another analyzing techniques individually and in isolation ignores the cumulative impact they will have on an individual victim, especially when combined with the conditions of confinement in CIA detention facilities, conditions not even discussed or considered, in the August 1, 2002 memos. These included complete isolation for long periods of time, total darkness, unsanitary conditions, extreme cold temperatures, and constant loud noise. Moreover, the CIA also does not appear to have obtained advice from the OLC that techniques the CIA referred to as “water dousing,” “nudity,” “dietary manipulation,” and use of the “abdominal slap” would not violate the Torture Statute until August 26, 2004, and even then, the “advice” did not constitute official OLC approval.³¹² Yet there is evidence that the CIA used these techniques, and in combination, before August 26, 2004.

Even before the Senate Summary was released, the CIA OIG Report documented a number of interrogation techniques allegedly used by the CIA that were not authorized. Though much of the relevant section of the report remains classified, included in the declassified portion were allegations, and in some cases confirmations, of the following: use of pressure points to bring about near unconsciousness; mock executions; other threats; use of a stiff brush; creating abrasions; stepping on a detainee’s ankles while shackled; use of cold

each withholding of information under a FOIA exemption) sent in response to an American Civil Liberties Union FOIA request, https://www.aclu.org/files/assets/torturefoia_vaughn_olc.pdf (accessed August 26, 2015).

³¹⁰ See Bradbury Combined Techniques Memo. See also admission of this fact by John Yoo after the Senate Summary was released, Dan Lamothe, “Former Bush lawyer: U.S. did not consider cumulative effects of ‘enhanced interrogation,’” *Washington Post*, December 12, 2014, <http://www.washingtonpost.com/news/checkpoint/wp/2014/12/12/former-bush-lawyer-u-s-did-not-consider-cumulative-effects-of-enhanced-interrogation/> (accessed April 19, 2009) (“‘We did not examine this question of how long you could use the methods for, or what’s their cumulative effect,’ Yoo said in an interview for C-SPAN’s ‘Newsmakers’ program that included Checkpoint and will air on television Sunday morning. ‘Quite frankly, we didn’t examine them at that time because in the rush of events, we were just focusing on one person, Abu Zubaida [sec] and the use of these methods we hoped would be one or very few times.’”). See also note 53 above.

³¹¹ See note 293 above.

³¹² Letter from Daniel Levin to acting CIA General Counsel John Rizzo, August 26, 2004 (hereinafter “Levin August 26, 2004 Letter to Rizzo”), <https://www.aclu.org/files/torturefoia/released/o82409/olcremand/2004olc85.pdf>, p. 2 (accessed April 23, 2015) (The letter responds to a request for “advice” on water dousing as well as three other techniques—dietary manipulation, nudity and abdominal slaps. Levin’s letter indicates that the water dousing as described, among other techniques discussed, would not in their opinion violate the Torture Statute but he also says the advice does not constitute OLC’s policy approval of the techniques described).

temperatures; rough or hard “takedown”³¹³; and unauthorized so called “water dousing” or waterboarding.³¹⁴ In one draft of the CIA OIG Report cited in the Senate Summary, the OIG concluded that in a number of cases, CIA interrogations went “well beyond what was articulated in the written DOJ legal opinion of August 1, 2002.”³¹⁵

Waterboarding and Water Dousing

The CIA OIG Report said “water dousing”³¹⁶ had been used since early 2003.³¹⁷ But the technique does not appear to have been officially approved until much later.³¹⁸ According to the Senate Summary, water dousing was not even designated by the CIA as a “standard” interrogation technique³¹⁹ until June 2003 and was later re-categorized by the CIA in 2004 as an “enhanced interrogation technique.”³²⁰ It appears that it was not until August 26, 2004 that the CIA for the first time got official “advice” from OLC that the technique, if used in the way described, would not violate the Torture Statute.³²¹ Even then, OLC made clear that the

³¹³ A “rough takedown” was described in the Senate Summary as being when “approximately five CIA officers would scream at a detainee, drag him outside of his cell, cut his clothes off, and secure him with Mylar tape. The detainee would then be hooded and dragged up and down a long corridor while being slapped and punched.” See Senate Summary, Findings and Conclusions, p. 4, p. 56, n. 278, and p. 190, n. 1122.

³¹⁴ CIA OIG report, pp. 41-79.

³¹⁵ Senate Summary, p. 190.

³¹⁶ This technique was defined and applied differently throughout the program. In the CIA’s initial request to OLC for authorization on March 2, 2003 it was explained as a technique whereby interrogators pour, from either a garden hose or container, potable water over a detainee, while he is either restrained by shackles and/or by an interrogator in a standing or supine position on a floor, bench, or similar level surface, naked or clothed. The water is intended to be applied so that it does not enter the nose or mouth. A “water dousing” session could last from 10 minutes to an hour. Fax from Scott Muller, CIA General Counsel, to Jack Goldsmith, March 2, 2004” (hereinafter “Muller Fax”), <https://www.aclu.org/sites/default/files/torturefoia/released/o82409/olcremand/2004olc22.pdf> (accessed April 23, 2015) (The fax asks Goldsmith to reaffirm OLC approval for the August 1, 2002 memos as well as approve several new techniques, one of which was water dousing). See also, *Delivered Into Enemy Hands*, pp. 48-51 where detainees Khalid Sharif, formerly Abu Hazim, and Mohammed Shoroeyia, who now goes by the name of Mohammed Ahmed Ben Soud and used to go by the name Abd al-Karim describe their “water dousing” and waterboarding experiences. They are referred to as Abu Hazim and Abd al-Karim in the Senate Summary respectively. See also Spencer Ackerman, “Torture by another name: CIA used ‘water dousing’ on at least 12 detainees,” *The Guardian*, October 16, 2015, <http://www.theguardian.com/law/2015/oct/16/cia-torture-water-dousing-waterboard-like-technique> (accessed October 25, 2015); Lindsay Wise and Jonathan S. Landay, “Despite denials, Senate torture report says waterboarding more widespread than CIA claims,” *McClatchy DC*, December 11, 2014, <http://www.mcclatchydc.com/news/nation-world/national/national-security/article24777370.html> (accessed October 25, 2015).

³¹⁷ CIA OIG, p. 76.

³¹⁸ Muller Fax (The fax asks Goldsmith to reaffirm OLC approval for the August 1, 2002 memos as well as approve several new techniques, one of which was water dousing).

³¹⁹ For an explanation of the difference between “standard” and “enhanced” interrogation techniques, see discussion in notes to section “Reauthorization of the torture program” above. According to the January 28, 2003 Guidance, CIA interrogators were to obtain advance approval to use “standard” interrogation techniques, “whenever feasible,” but were required to obtain advance approval for “enhanced” interrogation techniques—though in all instances use of both standard and enhanced techniques were supposed to be documented. (See CIA OIG Report, Appendix E). In the January 28, 2003 Guidance, a number of examples of standard and enhanced techniques are provided but “water dousing” is not listed in either category. (CIA, OIG report, Appendix E).

³²⁰ Senate Summary, p. 63, n. 315.

³²¹ Levin August 26 2004 Letter to Rizzo.

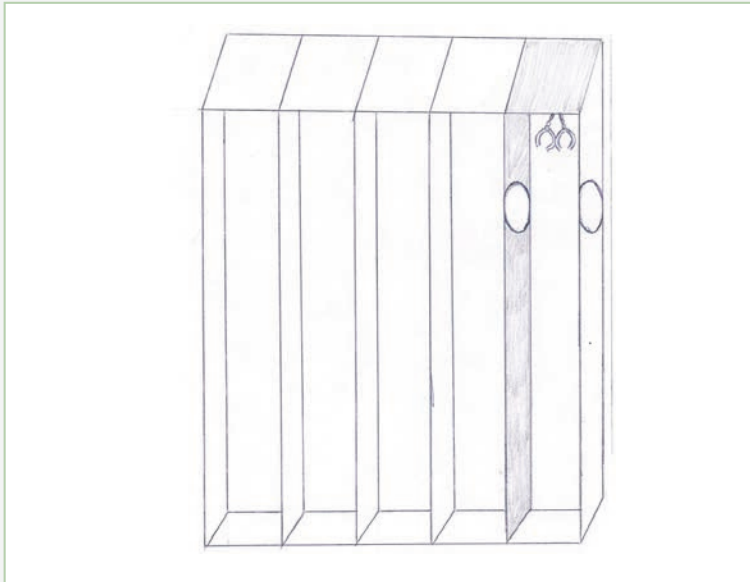

Instruments that the CIA Used at CIA “Black Sites” as Described and Drawn by One Former CIA Detainee

A sketch by Ben Soud, who formerly went by Mohammed Shoroeiya, as well as Abd al-Karim, depicts a narrow windowless box where he said he was held naked for one and a half days while speakers on each side of his ears blared loud music. © 2012 Ben Soud

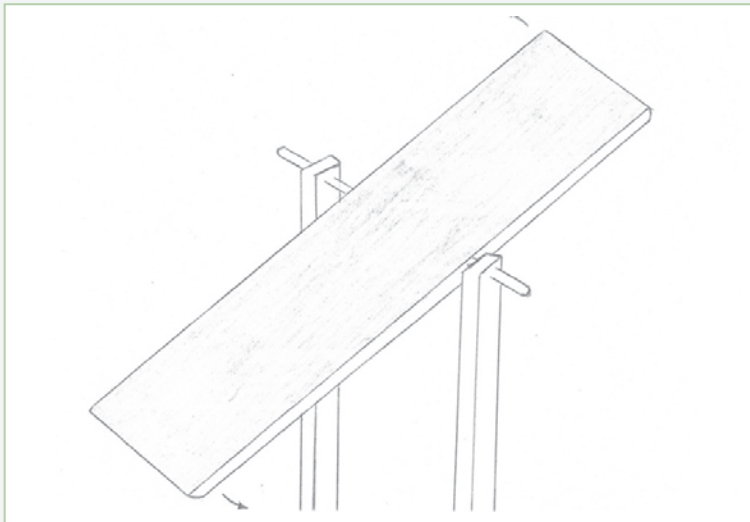

A sketch by Ben Soud formerly Mohammed Shoroeiya, as well as Abd al-Karim, depicts a wooden board to which he was strapped and on which his interrogators put him when he underwent abuse with water. © 2012 Ben Soud

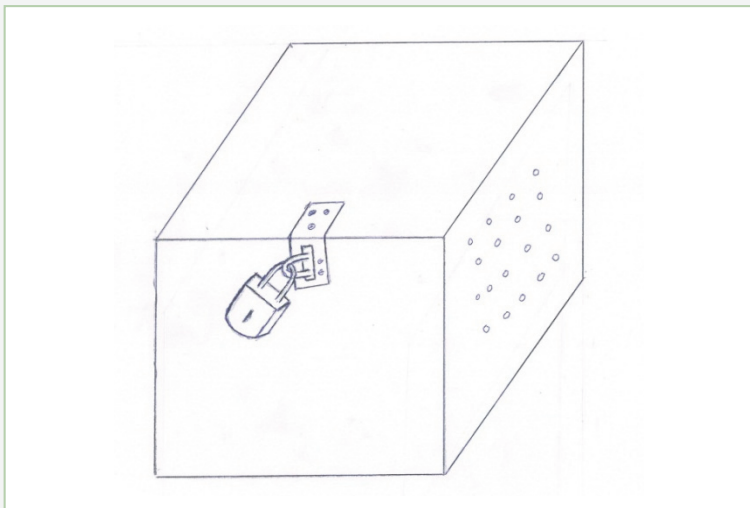

Ben Soud, formerly Mohammed Shoroeiya, as well as Abd al-Karim, said his captors would sometimes threaten to lock him in a small wooden box, like the one drawn by him to the left, and once did lock him such a box. © 2012 Ben Soud

“advice” did “not constitute the Department of Justice’s policy approval for the use of the technique.”³²² The OLC apparently did not provide official approval for the use of water dousing as an “enhanced interrogation technique” until May 2005.³²³

Nevertheless, the CIA used it in various ways beginning in early 2003.³²⁴ The Senate Summary documents use of “water dousing” on several detainees in ways that approximated “waterboarding” in April 2003.³²⁵ At detention cite Cobalt, known to be in Afghanistan,³²⁶ where the CIA held most of its detainees,³²⁷ CIA operatives would hold the detainee down while he was naked on a tarp on the floor with the tarp pulled around him to form a makeshift tub while cold or refrigerated water was poured on him.³²⁸ Other detainees were hosed down repeatedly while they were shackled naked, in the standing sleep deprivation position.³²⁹ As approved in 2005, interrogators were not supposed to allow any water to get into a detainee’s nose or mouth.³³⁰ However, this was not the way the water dousing was applied on many occasions.³³¹ In other cases detainees were completely submerged in tubs of water that was not just cold but filled with ice or “icy.”³³²

The CIA also “water doused” an unknown number of detainees while on a waterboard.³³³ Although this part of the CIA’s program is still classified, the Senate Summary says that the CIA used the technique “extensively” on a number of detainees without seeking or obtaining prior authorization.³³⁴ The practice prompted concern from at least one CIA interrogator who said: “I

³²² Ibid., p. 2.

³²³ “Bradbury Individual Techniques Memo,” May 5, 2015, p. 9 approving water dousing as one of 13 “enhanced interrogation techniques” which could be used, http://media.luxmedia.com/aclu/olc_05102005_bradbury46pg.pdf (accessed April 23, 2015).

³²⁴ CIA OIG report, p. 76.

³²⁵ Senate Summary, pp. 105-109. See also *Delivered Into Enemy Hands*, documenting water dousing accounts on two detainees Khalid Sharif, formerly known as Abu Hazim, and Mohammed Shoroeyia, formerly known as Abd Karim and who now goes by the name of Mohammed Ben Soud, during the same period, pp. 47-51. See also CIA OIG report, p. 76.

³²⁶ Adam Goldman and Julie Tate, “Decoding the secret black sites on the Senate’s report on the CIA interrogation program,” *Washington Post*, December 9, 2014, <https://www.washingtonpost.com/news/worldviews/wp/2014/12/09/decoding-the-secret-black-sites-on-the-senates-report-on-the-cia-interrogation-program/> (accessed August 26, 2015).

³²⁷ Senate Summary, Findings and Conclusions, p. 10.

³²⁸ Senate Summary, p. 105.

³²⁹ Senate Summary, p. 105.

³³⁰ See Bradbury Individual Techniques Memo, pp. 9-10 for rules about how water dousing was supposed to be done.

³³¹ See *Delivered into Enemy Hands*, pp. 50-51; See also Senate Summary, pp. 105-108.

³³² *Delivered Into Enemy Hands*, pp. 50-51; See also Senate Summary, pp. 104, n.610; 105, n. 616.

³³³ Senate Summary, p. 106.

³³⁴ Senate Summary, p. 106. See also note 618 on this page of the Senate Summary which says “for additional details see Volume III” which is still classified.

have serious reservations about watering [the detainees] in a prone position ... I think it goes beyond dousing and the effect, to the recipient, could be indistinguishable from the water board ... if it is continued [it] may lead to problems for us.”³³⁵

In 2008, then-CIA director Michael Hayden told the US Senate that the CIA had only used waterboarding on three detainees.³³⁶ But a report by Human Rights Watch, corroborated by the Senate Summary, provides strong evidence that the CIA waterboarded at least one other CIA detainee.³³⁷ Later media reports provide evidence the CIA used water on other detainees in other ways that induced the sensation of suffocation or drowning.³³⁸ As noted above, the Senate Summary documents the CIA’s use of water to inflict torture on detainees in ways that would often make it indistinguishable from waterboarding and on many more than three detainees.³³⁹ Additionally, the Senate Summary makes clear that even in the cases of the three detainees for which the CIA purports to have had authorization to waterboard, the way in which the CIA used the technique went far beyond what was authorized.³⁴⁰ During SERE

³³⁵ Senate Summary, p. 106.

³³⁶ Testimony of Michael Hayden in front of the Senate Select Committee on Intelligence, February 5, 2008, <http://www.intelligence.senate.gov/pdfs/110824.pdf>, p. 71-72 (accessed July 2, 2012) (“Let me make it very clear and to state so officially in front of this Committee that waterboarding has been used on only three detainees.”). The CIA waterboarded Khalid Sheikh Mohammed 183 times, Abu Zubaydah at least 83 times, and Abd al-Rahim al-Nashiri twice. CIA Office of the Inspector General, “Special Review: Counterterrorism Detention and Interrogation Activities (September 2001 – October 2003),” May 7, 2004, declassified in August 2009, <http://graphics8.nytimes.com/packages/pdf/politics/20090825-DETAIN/2004CIAIG.pdf> (accessed July 2, 2012), (“CIA OIG Report”), p. 90-91.

³³⁷ See Senate Summary, p. 107, n. 623, citing to the account of Mohammed Shoroeyia— who also went by the name of Abd al-Karim and now goes by the name of Mohammed Ben Soud who is identified in the Senate Summary as being one of the detainees in the CIA program—in the Human Rights Watch report *Delivered Into Enemy Hands*. The Senate Summary’s reference says that the full SSCI committee study, still classified, contains a photograph of a waterboard at detention site Cobalt even though there are no records of the CIA using the waterboard at that location. The waterboard device in the photograph is surrounded by buckets, with a bottle of unknown pink solution (filled two-thirds of the way to the top) and a watering can resting on the wooden beams of the board. See Senate Summary, p. 104, n. 245. In meetings between SSCI staff and the CIA in the summer of 2013, the CIA was unable to explain the presence of the board at that location as well as the buckets, the solution and watering cans. See Senate Summary, p. 51, n. 45. Ben Soud is one of three plaintiffs who have brought suit against Mitchell and Jessen. See *Abdullah Salim v. Mitchell*, Civil Action No. 2:15-CV-286-JLQ, October 13, 2015, https://www.aclu.org/sites/default/files/field_document/salim_v._mitchell_-_complaint_10-13-15.pdf (accessed October 14, 2015). See also video of Human Rights Watch initial interview with Ben Soud where he describes how the CIA used the waterboard on him: Human Rights Watch video interview with Ben Soud http://hrwnews.org/distribute/2012MENA_Libya_Rendition/ (at minute 1:25). See also *Delivered Into Enemy Hands*, pp. 48-49.

³³⁸ Spencer Ackerman, “Torture by another name: CIA used ‘water dousing’ on at least 12 detainees,” *The Guardian*; Lindsay Wise and Jonathan S. Landay, “Despite denials, Senate torture report says waterboarding more widespread than CIA claims,” *McClatchy DC*.

³³⁹ See *Delivered into Enemy Hands*, p. 48-51. See also Senate Summary, pp. 105-108.

³⁴⁰ See e.g., Senate Summary p. 43-44 (waterboarding sessions on Abu Zubaydah “resulted in immediate fluid intake and involuntary leg, chest and arm spasms” and “hysterical pleas.” In at least one waterboarding session, Abu Zubaydah “became completely unresponsive, with bubbles rising through his open, full mouth.” Abu Zubaydah remained unresponsive until medical intervention, when he regained consciousness and expelled “copious amounts of liquid.” See also pp. 87-88 “[Khalid Sheikh Mohammed] had been subjected to more than 65 applications of the waterboarding sessions between the afternoon of March 12, 2003 and the morning of March 13, 2003. CIA records note that KSM vomited during and after the [waterboarding] procedure.”

training (see below) from which waterboarding was derived, most trainees experienced the technique only once or twice, knew that it would last a short period of time, and knew that they would not be significantly harmed by the training.³⁴¹ During CIA interrogations, detainees however were subjected to repeated applications over prolonged periods of time.³⁴²

“Rectal Rehydration” and Other Sexual Abuse

The CIA also used “rectal rehydration” or “rectal feeding” which, as described in the Senate Summary, would amount to sexual assault, on at least five different detainees. The practice, not known to have been authorized by the OLC, involved inserting pureed food or liquid nutrients into the detainee’s rectum through a tube, presumably without his consent.³⁴³ The CIA claims this was a medically necessary procedure and not an “enhanced interrogation technique.”³⁴⁴ The Senate Summary, however, states the procedure was done “without evidence of medical necessity.”³⁴⁵ Medical experts report that use of this type of procedure without evidence of medical necessity is “a form of sexual assault masquerading as medical treatment.”³⁴⁶ At least three other detainees were threatened with “rectal rehydrations.” Allegations of excessive force used on two detainees during rectal exams to do not appear to have been properly investigated.³⁴⁷ One of those two detainees, Mustafa al-Hawsawi, was later diagnosed with chronic hemorrhoids, an anal fissure, and symptomaticrectal prolapse.³⁴⁸ Some CIA detainees have also reported having suppositories

³⁴¹ OPR Report, p. 136, n. 109.

³⁴² For example, during a 17 day period when the CIA used a number of “enhanced interrogation techniques” on Abu Zubaydah in combination, including walling, attention grasps, slapping, facial hold, stress positions, cramped confinement, white noise and sleep deprivation” it also waterboarded him “2-4 times a day...with multiple iterations of the watering cycle during each application.” Senate Summary, p. 42. During this period Abu Zubaydah frequently “cried,” “begged,” “pleaded,” and “whimpered,” to his interrogators. Ibid. He also vomited during some waterboarding sessions. Ibid. CIA detainee Khalid Sheikh Mohammed was waterboarded at least 183 times. Senate Summary, p. 85. A medical officer later wrote of Khalid Sheikh Mohammed’s water boarding sessions that he was “ingesting and aspiration [sic] a LOT of water,” and that “[i]n the new technique we are basically doing a series of near drownings.” Senate Summary, p. 86.

³⁴³ Senate Summary, p. 100, n. 584.

³⁴⁴ CIA Response, p. 55. (“The record clearly shows that CIA medical personnel on scene during enhanced technique interrogations carefully monitored detainees’ hydration and food intake to ensure HVD’s [High Value Detainees] were physically fit and also to ensure they did not harm themselves...Medical personnel who administered rectal rehydration did not do so as an interrogation technique or as a means to degrade a detainee but, instead, utilized the well acknowledged medical technique to address pressing health issues.”)

³⁴⁵ Senate Summary, p. 100.

³⁴⁶ “CIA Torture Report Highlights Unnecessary Medical Procedure,” Physicians for Human Rights Press Release, December 10, 2014, <http://physiciansforhumanrights.org/press/press-releases/cia-torture-report-highlights-unnecessary-medical-procedure.html> (accessed August 24, 2015).

³⁴⁷ Senate Summary, p. 100, n. 584.

³⁴⁸ Senate Summary, p. 100, n. 584.

forced into their anus,³⁴⁹ and other detainees have reported CIA operatives sticking fingers in their anus.³⁵⁰

Other Unauthorized Techniques

There is considerable evidence that many detainees in CIA custody were shackled with their hands above their heads for prolonged periods of time, sometimes days. This was often done while detainees were naked, at times diapered, and was often combined with sleep deprivation.³⁵¹ The OLC does not appear to have approved shackling detainees with their hands above their heads at all until the May 10, 2005 Bradbury memos. Even then, it approved the technique only in conjunction with sleep deprivation for up to two hours.³⁵² The CIA does not appear to have received approval from the OLC to use nudity, the abdominal slap, and dietary manipulation on detainees until at least August 26, 2004, yet it used these techniques on numerous detainees prior to these approvals.³⁵³ The CIA contends that diapers were authorized for use on detainees only “for sanitation and hygiene purposes,” but CIA records indicate in some cases the central purpose was to “cause humiliation” and “induce a sense of helplessness.”³⁵⁴ Similarly, the CIA represented to the OLC that nude detainees were not “wantonly exposed to other detainees or detention facility staff” but many were nevertheless kept in a central area and “walked around” by guards as a form of humiliation.³⁵⁵

Even though techniques considered “standard,” such as days of sleep deprivation and “water dousing,” amounted to torture or ill-treatment, the Senate Summary concludes that at least 17 detainees were subjected to “enhanced interrogation techniques” without authorization.³⁵⁶

³⁴⁹ *El-Masri v. Former Yugoslav Republic of Macedonia*, (Application no. 39630/09), Judgment of 13 December 2012, available at <http://hudoc.echr.coe.int/sites/eng/pages/search.aspx?i=001-115621> (accessed April 20, 2015), para. 21, 40, 46, 124. See *Delivered into Enemy Hands*, p. 36, n. 123.

³⁵⁰ Craig S. Smith and Souad Mekhennet, “Algerian Tells of Dark Term in U.S. Hands,” *New York Times*, July 7, 2006, <http://www.nytimes.com/2006/07/07/world/africa/07algeria.html> (accessed April 20, 2015).

³⁵¹ Senate Summary, p. 49; See also p. 53 (“Ridha al-Najjar underwent “hanging” described as “handcuffing one or both of his wrists to an overhead horizontal bar” for 22 hours each day for two consecutive days); p. 103, n. 597, p. 497, n. 2717; Several other detainees reported being shackled with their hands above their heads for significant periods while naked and diapered at a CIA detention facility in Afghanistan that can be identified in the Senate Summary as Cobalt. In one case this lasted a day and a half, on another occasion for three days, and one former detainee said he felt like it lasted for 15 days. See *Delivered into Enemy Hands*, pp. 44, 45 and 63.

³⁵² Bradbury Combined Techniques Memo, p. 11. The CIA appears to have separately approved this for up to four hours. See Senate Summary, p. 415; see also p. 498, n. 2723.

³⁵³ Senate Summary, p. 105.

³⁵⁴ Senate Summary, p. 415.

³⁵⁵ Senate Summary, p. 415.

³⁵⁶ Senate Summary, pp. 101-103.

Conditions of Confinement at a CIA “Black Site” as Described by Former Detainees

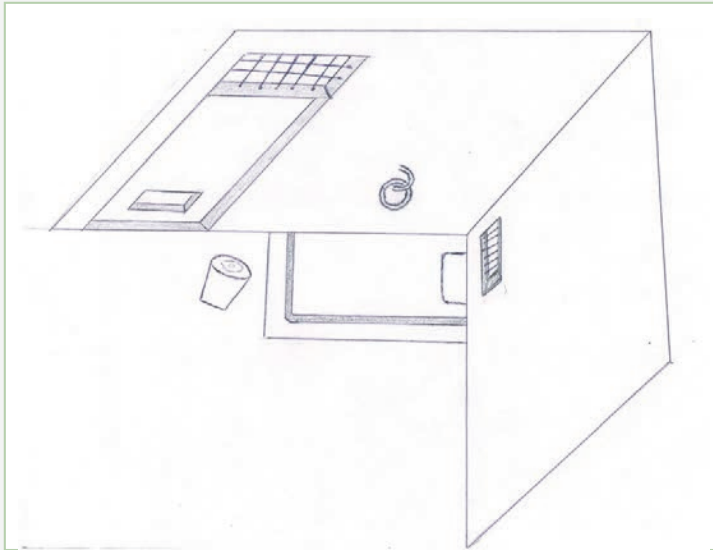

A sketch by Ben Soud, who formerly went by Mohammed Shoroeyiya as well as Abd al-Karim, depicts his cell. © 2012 Ben Soud

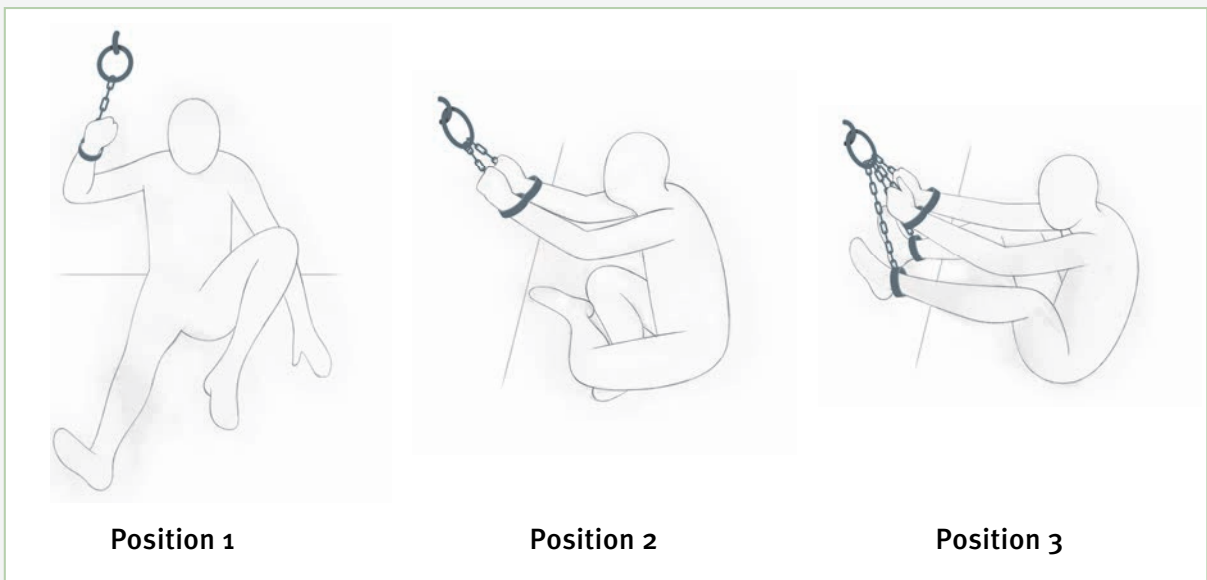

Four former CIA detainees, Ben Soud (formerly Mohamed Shoroeyiya and Abd al-Karim), Khalid al-Sharif, Majid al-Maghrebi, and Saleh Di’iki, all said that for most of the duration of their detention at the first site in Afghanistan where they were held, they were put in one of the three positions depicted on the previous page (referred to as Positions 1, 2, and 3). They were held in these positions for varying amounts of time ranging from multiple days to months. For detailed accounts of their detention and conditions of confinement see the Human Rights watch Report *“Delivered Into Enemy Hands: US-Led Abuse and Rendition of Opponents to Gaddafi’s Libya.”* These illustrations were drawn based on the testimony and re-enactments of the positions by the victims. One of victims, Khalid al-Sharif, was shown the three images and said they were very accurate depictions.

Though use of unapproved techniques on even one detainee is a serious allegation, there are a number of reasons why this number might be low. First, it does not include cases in which CIA interrogators had authorization but applied the techniques in an unauthorized manner.³⁵⁷ Second, the Senate Summary is based on CIA records,³⁵⁸ yet the CIA kept poor records on the use of enhanced interrogation techniques at detention facility Cobalt³⁵⁹ where more than half of the CIA's known 119 detainees were held.³⁶⁰ Finally, the Senate Summary states that its number of 119 total detainees is a conservative estimate.³⁶¹

Libyan Survivors' Accounts of Abuse in CIA Custody

Former detainees released from CIA custody have provided accounts of CIA detention and torture not documented in the Senate Summary.³⁶² One is former CIA detainee Adnan al-Libi, who is mentioned in the Senate Summary only twice. The first time, he is listed as one of several detainees threatened with rectal rehydration.³⁶³ The second time he is referred to in three lines of text stating that he was subjected to sleep deprivation beyond

what was authorized for “46.5 hours, 24 hours, and 48 hours, with a combined three hours of sleep between sessions.”³⁶⁴ These references do not convey the full scale of the abuse al-Libi experienced, the horrendous conditions to which he was subjected, or the pain and suffering he endured.

When Human Rights Watch interviewed al-Libi, long before the Senate Summary was released,

³⁵⁷ Senate Summary, p. 104.

³⁵⁸ This includes operational cables, intelligence reports, internal memoranda and emails, briefing materials, interview transcripts, contracts, and other records. Senate Summary, Forward, p. 5 of 6.

³⁵⁹ See Senate Summary, p. 51; see also Senate Summary, p. 107, n. 623 (“the full nature of CIA interrogations at detention site [] remains largely unknown. Detainees at detention site [] were subjected to techniques that were not recorded in cable traffic, including multiple periods of sleep deprivation, required standing, loud music, sensory deprivation, extended isolation, reduced quantity of food, nudity and ‘rough treatment.’”) The name of the detention site in footnote 623 is blacked out but it is clear from other parts of the Senate Summary that this is detention site Cobalt. See Senate Summary, p. 51; see also p. 104, n. 610; p. 106, n. 620; it says so specifically on page 51 and in notes 245 and 620 it says that the photograph of the waterboard was taken at detention site Cobalt.

³⁶⁰ Senate Summary, Findings and Conclusions, p. 10.

³⁶¹ Senate Summary, p. 14, n. 26.

³⁶² See for example, the harrowing account of Suleiman Abdullah Salim in a complaint filed by the American Civil Liberties Union in *Abdullah Salim v. Mitchell*, Civil Action No. 2:15-CV-286-JLQ, October 13, 2015, https://www.aclu.org/sites/default/files/field_document/salim_v._mitchell_-_complaint_10-13-15.pdf (accessed October 14, 2015). Abdullah Salim underwent extreme forms of torture at two CIA black sites and was held by the CIA for 16 months. (He was held by the US military for another four years before he was released on the basis of not posing a threat to the US). Yet he is barely mentioned in the Senate Summary other than in a few lines of text. One of these is a footnote where it states that he was one of “numerous detainees were stripped and shackled, nude, in the standing stress position for sleep deprivation or subjected to other enhanced interrogation techniques prior to being questioned by an interrogator.” See Senate Summary, p. 484, n. 2639.

³⁶³ Senate Summary, p. 100, n. 584.

³⁶⁴ Senate Summary, p. 134.

he said he thought one of his sleep deprivation episodes lasted for more like 15 days, though he said he was in a windowless cell with little ability to track time with great accuracy.³⁶⁵ He also said the sleep deprivation was accomplished by forcing him to stand all those days with his hands chained above his head, feet shackled to the ground so that if his legs buckled, he would have to hang from his arms in order to try and sleep—something impossible to do. He endured this while diapered and otherwise naked. Once released from the standing sleep deprivation position and allowed to shower, al-Libi said he could not move his arms and so guards had to bathe him. “I was there for 15 days, hanging from my arms, another chain from the ground. They put a diaper on me but it overflowed so there was every type of stool everywhere.”³⁶⁶ He said he had hallucinations and felt like he was going insane and was going to die.³⁶⁷ Nor does the Senate Summary explain that, in addition to this one particular incident of sleep deprivation, the CIA held him for a total of eight months in total isolation, in pitch black windowless cells, subjected to freezing cold temperatures as well as well as nudity, painful stress positions, days of continuous sleep deprivation, dietary

manipulation, and the blare of loud Western music 24 hours a day, all at the same time.³⁶⁸

Other former detainees, entirely unconnected to al-Libi, reported having heard his screams while they too were held at the facility.³⁶⁹ One, Mohamed Bashmilah, identified as Mohammad al-Shomaila in the Senate Summary, is mentioned only once, in a footnote that lists the names of at least 26 detainees that the CIA for the first time admitted publicly to have wrongfully detained.³⁷⁰ The summary does not mention that Bashmilah was first abducted in Jordan with the help of the US, tortured there, rendered to Afghanistan where the CIA held him in the same facility as al-Libi, in cold, dark windowless cells, with only a bucket for a toilet, chained to the floor and wall and in unsanitary conditions. He remained in the same diaper in which he was transported to the facility for 15 days before he was provided with clothes, among other examples of mistreatment.³⁷¹ He tried to kill himself three times, once by cutting himself and using his own blood to write “this is unjust” on the wall.³⁷² The CIA held him for 19 months before transferring him to Yemen where he was detained for nine more months before being convicted of forgery and then released.³⁷³

³⁶⁵ *Delivered Into Enemy Hands*, pp. 62-64.

³⁶⁶ *Delivered Into Enemy Hands*, p. 63.

³⁶⁷ *Ibid.*

³⁶⁸ *Delivered Into Enemy Hands*, pp. 60-66.

³⁶⁹ *Delivered Into Enemy Hands*, p. 63, fn. 221; See also Bashmilah Declaration, page 21, <http://chrgj.org/wp-content/uploads/2012/07/declarationofbashmilah.pdf> (accessed February 12, 2015).

³⁷⁰ SSCI, p. 16, n. 32.

³⁷¹ Bashmilah Declaration, p. 15.

³⁷² Scott Shane, “Amid Details on Torture, Data on 26 Who Were Held in Error,” *New York Times*, December 12, 2014, http://www.nytimes.com/2014/12/13/us/politics/amid-details-on-torture-data-on-26-held-in-error-.html?_r=1 (accessed February 12, 2015).

³⁷³ *Ibid.*

Although the Senate Summary contains numerous descriptions of torture of detainees in CIA custody, there are evidently countless other abuses that are not documented in it. Just as the Justice Department’s Durham investigation was seriously flawed by the failure to include accounts from torture survivors, the Senate Summary would have greatly benefitted from access to the survivors themselves. Any future investigation, if it is to have any credibility, needs to include in-depth interviews with those who were detained and subjected to abuse in the CIA program.

Individuals Involved in “Unauthorized” Techniques

Mitchell and Jessen are among those who could be prosecuted for use of unauthorized techniques. They were the only two interrogators permitted to take part directly in the initial application of “enhanced interrogation techniques” on Abu Zubaydah and they also were directly involved in the application of “enhanced interrogation techniques,” including waterboarding, on Khalid Sheikh Mohammed and Abd al-Nashiri.³⁷⁴ The Senate Summary makes clear that they applied techniques in ways that were unauthorized on many occasions.³⁷⁵ Jessen also assisted CIA “Officer 1” in the interrogation of Gul Rahman (see below) who died in custody.³⁷⁶

The Senate Summary does not identify who carried out abuses that went beyond what were authorized but it does identify some by pseudonym.

³⁷⁴ Senate Summary, p. 40 (“According to CIA records, only the two CIA contractors, Swigert and Dunbar, were to have contact with Zubaydah.”); see also pp. 45-46 (“A cable from Detention site Green, which CIA records indicate was authored by Swigert and Dunbar, also viewed the interrogation of Zubaydah as a success....” The cable further recommended that psychologists—a likely reference to contractors Swigert and Dunbar—“familiar with interrogation, exploitation and resistance to interrogation should shape compliance of high value captives prior to debriefing by substantive experts.”); see also Senate Summary p. 65 (“As described later in this summary, [Swigert and Dunbar] had earlier subjected [Khalid Sheikh Mohammed] to the waterboard and other CIA enhanced interrogation techniques.”); see also p. 84 (“Between March [REDACTED], 2003, and March 9, 2003, contractors Swigert and Dunbar, and a CIA interrogator, [REDACTED], used the CIA’s enhanced interrogation techniques against [Khalid Sheikh Mohammed], including nudity, standing sleep deprivation, the attention grab and insult slap, the facial grab, the abdominal slap, the kneeling stress position, and walling.”); see also p. 108, fn. 631 (“The cable also noted that CIA contractor Hammond Dunbar had arrived at the detention site and was participating in Hambali’s interrogations as an interrogator.”)

³⁷⁵ For example, from August 4, 2002 through August 23, 2002, the CIA subjected Abu Zubaydah to “enhanced interrogation techniques” on a near 24-hour-per-day basis. [Swigert and Dunbar] placed a rolled towel around Zubaydah’s neck and slammed him into a concrete wall. Senate Summary, pp. 40-41. Also, prior to his death, Jessen and CIA Officer 1 subjected Gul Rahman to “48 hours of sleep deprivation, auditory overload, total darkness, isolation, a cold shower, and rough treatment” that was not approved in advance. p. 54. Jessen was also involved in what the CIA called a “rough takedown” of Gul Rahman which involved dragging him outside, cutting off all his clothes, slapping and, punching him. Jessen stated that although it was “obvious they were not trying to hit him as hard as they could, “a couple of times the punches were forceful.” Senate Summary, p. 56, no. 278. See also for example, Senate Summary pp. 83-84, 84-85; 88; 90 and 165.

³⁷⁶ Senate Summary, p. 54.

Since the Senate Summary was released, Mitchell has said that the summary unfairly maligns him and Jessen.³⁷⁷ For example, he said that the Senate Summary mentions a number of instances when CIA interrogators reported abuse and the use of unauthorized techniques but it does not mention that he and Jessen were the ones who reported it. Mitchell also said he was one of the interrogators who reported abuses to the CIA inspector general, initiating what resulted in a May 2004 OIG report.³⁷⁸ The Senate Summary identifies CIA “Officer 1” as being in charge of the Cobalt facility during a time when numerous detainees were subjected to “unapproved coercive interrogation techniques” and a detainee, Gul Rahman, died in CIA custody.³⁷⁹ Officer 1 has been identified as Matthew Zirbel.³⁸⁰ Zirbel was involved directly in the interrogation of Gul Rahman and ordered the detention conditions that led to his death.³⁸¹ Zirbel was not sanctioned for his role in Rahman’s death.³⁸² Four months after the death, Zirbel received a bonus for his “consistently superior work.”³⁸³ The Senate Summary also identifies Officer 1, Zirbel, as the officer involved in a water dousing session that was not authorized. It resulted in the detainee “turn[ing] blue” and a physician’s assistant stepping in to remove the cloth over the detainee’s mouth so he could breathe.³⁸⁴

The Senate Summary also explains that a “senior debriefer” informed the CIA Inspector General that she “heard” that at detention site Cobalt someone identified as Officer 2 “hung detainees up for long periods with their toes barely touching the ground.”³⁸⁵ Officer 2 is also identified in the summary as having been involved in the interrogation of Abd al-Nashiri, when a number of unauthorized techniques were used.³⁸⁶

³⁷⁷ Jason Leopold, “Psychologist James Mitchell Admits He Waterboarded al Qaeda Suspects,” *Vice News*, December 15, 2015, <https://news.vice.com/article/psychologist-james-mitchell-admits-he-waterboarded-al-qaeda-suspects> (accessed April 29, 2015) where Mitchell admits his involvement in waterboarding sessions used on all three detainees.

³⁷⁸ *Ibid.*

³⁷⁹ Senate Summary, p. 50.

³⁸⁰ Ken Silverstein, “The Charmed Life of a CIA Torturer: How Fate Diverged for Matthew Zirbel, aka CIA Officer 1, and Gul Rahman,” *The Intercept*, December 15, 2014, <https://firstlook.org/theintercept/2014/12/15/charmed-life-cia-torturer/> (accessed April 29, 2015). Emptywheel, “Immunizing Crimes: Blankfein, Zirbel, and Arpaio, but Whither Corzine?” *Emptywheel*, September 2, 2012, <https://www.emptywheel.net/2012/09/02/immunizing-crimes-blankstein-zirbel-and-arpaio-but-whither-corzine/> (accessed November 14, 2015), see “*Matt Zirbel.”

³⁸¹ Senate Summary, p. 54.

³⁸² Senate Summary, p. 55.

³⁸³ *Ibid.*

³⁸⁴ Senate Summary, p. 106.

³⁸⁵ Senate Summary, p. 58, no. 278.

³⁸⁶ Senate Summary, p. 69.

For example, Officer 2 put Nashiri in a standing stress position with his hands affixed over his head for approximately two-and-a-half days; placed a pistol near Nashiri's head while blindfolded and revved a power drill near his body; slapped Nashiri multiple times on the back of the head during interrogation; implied his mother would be brought before him and sexually abused; gave Nashiri a forced bath using a stiff brush; and used improvised stress positions that caused cuts and bruises resulting in the intervention of a medical officer, who was concerned that Nashiri's shoulders would be dislocated from using the stress positions.³⁸⁷

The Senate Summary also documents that Officer 2 was not properly trained and had "anger management" issues.³⁸⁸ Officer 2 is not further identified in the Senate Summary, but the *Washington Post* identified Albert El Gamil as a CIA linguist who interrogated Nashiri, subjected him to a mock execution, and put a drill to his head.³⁸⁹ The CIA inspector general also reported on those events.

One senior CIA official identified as "the Deputy Chief of Alec Station" throughout the Senate Summary has been named in press reports as Alfreda Bikowsky.³⁹⁰ She is reported to have participated in interrogation sessions that involved waterboarding, walling, and other techniques that amount to torture, and observed others engaged in such techniques.³⁹¹ She is also said to have advocated for the rendition of Khaled el-Masri, a German citizen the CIA wrongfully detained, and to have done so for many months after his

³⁸⁷ Senate Summary, pp. 69-70. One of the definitions of "severe mental pain or suffering" under the Torture Statute is the "threat of imminent death" or the "threat that another person will imminently be subjected to death" or "severe physical pain or suffering." See 18 U.S.C. 2340(2)(D).

³⁸⁸ Senate Summary p. 68, n. 345.

³⁸⁹ Adam Goldman, "The hidden history of the CIA's prison in Poland," *Washington Post*, January 23, 2004, https://www.washingtonpost.com/world/national-security/the-hidden-history-of-the-cias-prison-in-poland/2014/01/23/b77f6ea2-7c6f-11e3-95c6-0a7aa80874bc_story.html (accessed November 13, 2015).

³⁹⁰ Jane Mayer, "The Unidentified Queen of Torture," *The New Yorker*, December 18, 2014, <http://www.newyorker.com/news/news-desk/unidentified-queen-torture> (accessed June 29, 2015); Glenn Greenwald and Peter Maass, "Meet Alfreda Bikowsky, the Senior Officer at the Center of the CIA's Torture Scandal," *The Intercept*, December 19, 2014, <https://firstlook.org/theintercept/2014/12/19/senior-cia-officer-center-torture-scandals-alfreda-bikowsky/> (accessed June 29, 2015); Matthew Cole, "Bin Laden Expert Accused of Shaping CIA Deception on 'Torture' Program," *NBC News*, December 16, 2014, <http://www.nbcnews.com/news/investigations/bin-laden-expert-accused-shaping-cia-deception-torture-program-n269551> (accessed June 29, 2015).

³⁹¹ Senate Summary p. 91, where she is reported to have taken part in intensive interrogation sessions that included waterboarding Khalid Sheikh Mohammed ("Mukie," Bikowsky reportedly said referring to Khalid Sheikh Mohammed, "is going to be hatin' life on this one.") See also Senate Summary, p. 43, n. 197 where she is reported to have been present during intense waterboarding sessions of Abu Zubaydah; Matthew Cole, "Bin Laden Expert Accused of Shaping CIA Deception on 'Torture' Program," *NBC News*, December 16, 2014, <http://www.nbcnews.com/news/investigations/bin-laden-expert-accused-shaping-cia-deception-torture-program-n269551> (accessed August 20, 2015).

mistaken identity was realized.³⁹² She was not disciplined for her role in his continued wrongful detention and was in fact promoted to run the “Global Jihad Unit.”³⁹³ The Senate Summary also accuses her of falsely reporting in CIA cables that the CIA program was much more effective than it actually was, claiming, inaccurately for example that key operatives were identified and plots thwarted as a result of enhanced interrogation techniques.³⁹⁴ These cables would then serve as a “template” on which future justifications of the program were based.³⁹⁵ Bikowsky reportedly now holds a senior position at the CIA equivalent to that of a general in the army.³⁹⁶

Other Criminal Charges

In addition to torture and conspiracy to torture, there are a number of other charges that US authorities could bring either on their own or along with conspiracy. These include assault, sexual abuse, murder, and war crimes. In addition, the crime of conspiracy can be brought as a stand-alone charge under the federal conspiracy statute,³⁹⁷ allowing prosecutors to charge conspiracy even if the underlying offense is never completed.³⁹⁸ In either case, whether charged on its own or along with another substantive offenses, the elements of conspiracy discussed above would need to be established in order to sustain the charge.

Assault

Federal law criminalizes various degrees of assault, from “simple assault,” to assault with a deadly weapon, to assault that results in “serious bodily injury.”³⁹⁹ The assault must occur

³⁹² Senate Summary, pp. 128-129.

³⁹³ Matthew Cole, “Bin Laden Expert Accused of Shaping CIA Deception on ‘Torture’ Program,” *NBC News*, December 16, 2014, <http://www.nbcnews.com/news/investigations/bin-laden-expert-accused-shaping-cia-deception-torture-program-n269551> (accessed August 20, 2015).

³⁹⁴ Senate Summary, pp. 185-86, 191-92. The inaccurate representations included assertions that the information obtained from the use of “enhanced interrogations” saved “countless American lives inside the US and abroad” and that without the use of such techniques “we will not be able to prosecute this war.” Senate Summary, p. 86.

³⁹⁵ *Ibid.*

³⁹⁶ Mayer, “The Unidentified Queen of Torture,” *The New Yorker*; Cole, “Bin Laden Expert Accused of Shaping CIA Deception on ‘Torture’ Program,” *NBC News*.

³⁹⁷ 18 U.S.C. sec. 371 is the federal conspiracy statute. It states: “If two or more persons conspire either to commit any offense against the United States ... and one or more of such persons do any act to effect the object of the conspiracy, each shall be fined under this title or imprisoned not more than five years, or both.”

³⁹⁸ *United States v. Rehak*, 589 F.3d 965, 971 (8th Cir. 2009); see also *United States v. Jimenez Recio*, 537 U.S. 270, 274 (2003) (the conspiratorial “agreement is a distinct evil, which may exist and be punished whether or not the substantive offense ensues.”).

³⁹⁹ 18 USC section 113. Simple assault (section 113(a)(5)) is defined as either a willful attempt to inflict injury upon the person of another, or by a threat to inflict injury upon the person, when coupled with an apparent present ability, causes a reasonable apprehension of immediate bodily harm. See *United States v. Chestaro*, 197 F.3d 600, 604-05 (2d Cir. 1999)

within the special maritime and territorial jurisdiction of the US.⁴⁰⁰ A CIA detention facility would appear to be within the “special maritime and territorial jurisdiction” of the US.⁴⁰¹ The crime of simple assault is “committed by either a willful attempt to inflict injury upon the person of another, or by a threat to inflict injury upon the person of another which, when coupled with an apparent present ability, causes a reasonable apprehension of immediate bodily harm.”⁴⁰² Several “standard” CIA practices would seem to amount to assault:

- Though not included among “enhanced interrogation techniques,” what the CIA called “rough takedowns” were part of the CIA’s program according to the Senate Summary. This involved several CIA personnel rushing simultaneously at a detainee while in his cell and while they were yelling and screaming. They then cut off all this clothes, secured him with tape, put a hood on him, slapped and punched him, and dragged him outside, up and down a corridor several times through the dirt. This caused abrasions on the detainee’s hands, face and legs.⁴⁰³
- Another technique called “walling” involved shoving a detainee repeatedly into a wall that was supposed to be made out of flexible material while the defendant

(rejecting contention that federal assault statute is void for vagueness) and *United States v. Dupree*, 544 F.2d 1050, 1051-52 (9th Cir. 1976) (same). The various other types of assault available under section 113 increase the penalty depending upon certain elements. Relevant subsections of the subsections of 113 include assault with intent to commit any felony (which includes torture under 18 USC 2340A) except murder (section 113(a)(2)), punishable by not more than 10 years and a fine; assault by striking, beating, or wounding (section 113(a)(4)) punishable by not more than one year and a fine; simple assault (section 113(a)(5)), punishable by not more than six months and a fine; and assault resulting in substantial bodily injury (section 113(a)(6)), punishable by no more than 10 years and a fine. “Substantial bodily injury” is defined as an injury that involves a temporary but substantial disfigurement or a temporary but substantial loss or impairment of the function of any bodily member, organ or mental faculty. 18 USC section 113(b)(1). “Serious bodily injury,” is defined the way it is described in 18 USC 1365 to mean bodily injury which involves: a substantial risk of death; extreme physical pain; protracted and obvious disfigurement; or protracted loss or impairment of the function of a bodily member, organ, or mental faculty.

⁴⁰⁰ 19 USC section 113(a).

⁴⁰¹ Section 18 USCS § 7 is the statute that defines special maritime and territorial jurisdiction of the United States (SMTJ). Section 7(3) states the following is SMTJ: “[a]ny lands reserved or acquired for the use of the United States, and under the exclusive or concurrent jurisdiction thereof ... for the erection of a fort, magazine, arsenal, dockyard, or other needful building.” Section 7(7) also states the following is SMTJ: “[a]ny place outside the jurisdiction of any nation with respect to an offense by or against a national of the United States.” Section 7(9)(A) also states with respect to offenses committed by or against a national of the United States that the SMTJ includes: “the premises of United States diplomatic, consular, military or other United States Government missions or entities in foreign States, including the buildings, parts of buildings, and land appurtenant or ancillary thereto or used for purposes of those missions or entities, irrespective of ownership.” Further, the US recently acknowledged for the purposes interpreting obligations under the Convention against Torture, that it understands any territory under its jurisdiction will extend to “all places that the State Party controls as a governmental authority.” See Acting Legal Adviser McLeod: U.S. Affirms Torture is Prohibited at All Times in All Places,” Opening Statement of Mary E. McLeod, Acting Legal Adviser U.S. Department of State during review by the Committee against Torture, November 12-13, 2014 – Geneva, <https://geneva.usmission.gov/2014/11/12/acting-legal-adviser-mcleod-u-s-affirms-torture-is-prohibited-at-all-times-in-all-places/> (accessed February 14, 2015).

⁴⁰² *United States v. Chestaro*, 197 F.3d 600, 605 (2d Cir. N.Y. 1999) interpreting the meaning of “assault” criminalized in 18 USC sec. 113.

⁴⁰³ Senate Summary, p. 190, n. 1122.

had a foam ring around his neck to prevent whiplash.⁴⁰⁴ However, the Senate Summary states that during one of the walling sessions, James and Mitchell placed a rolled towel around Zubaydah’s neck and slammed him into a concrete wall. ⁴⁰⁵

In addition, many specific instances of conduct that would amount to assault have been reported. A non-exhaustive list includes:

- Nine of 14 detainees in CIA custody interviewed by the International Committee of the Red Cross (ICRC) alleged that they had been subjected to daily beatings during the initial period of their detention.⁴⁰⁶ Their beatings involved “repeated slapping, punching and, less often, kicking, to the body and face, as well as a detainee having his head banged against a solid object.”⁴⁰⁷ These beatings lasted up to half an hour and were repeated throughout the day and again on subsequent days. They took place during periods ranging from one week up to two to three months.⁴⁰⁸
- Khaled Sheikh Mohammed, one of the detainees interviewed by ICRC, alleged that on a daily basis during the first month of interrogation in his third place of CIA detention: “if I was perceived not to be cooperating I would be placed against a wall and subjected to punches and slaps in the body, head and face.”⁴⁰⁹ Similarly, Walid bin Attash, told the ICRC that: “every day for the first two weeks [in CIA custody in Afghanistan] I was subjected to slaps to the face and punches to the body during interrogation.”⁴¹⁰
- The Grand Chamber of the European Court of Human Rights made a determination of fact in *El-Masri v. The Former Yugoslav Republic of Macedonia*, relying on a 2007 report conducted by the Council of Europe’s Committee on Legal Affairs and Human Rights, that former detainee Khaled El-Masri was “beaten severely from all sides”

⁴⁰⁴ Bybee II Memo, p. 13. Bradbury Individual Techniques Memo, p. 32.

⁴⁰⁵ Senate Summary, pp. 40-41.

⁴⁰⁶ International Committee of the Red Cross, *ICRC Report on the Treatment of Fourteen “High Value Detainees” in CIA Custody*, (February 2007), <http://assets.nybooks.com/media/doc/2010/04/22/icrc-report.pdf> (accessed April 20, 2015), p. 13. The 14 detainees include Abu Zubaydah, Ramzi Mohammed Binalshib, Abdelrahim Hussein Abdul Nashiri, Mustafha Ahmad Al Hawsawi, Khaled Sheikh Mohammed, Majid Khan, Ali Abdul Aziz Mohammed, Walid Bin Attash, Mohammed Farik Bin Amin, Mohammed Nazir Bin Lep, Encep Nuraman, Haned Ahmad Guleed, Ahmed Khalafan Ghailani, and Mustafah Faraj Al Azibi. *Ibid.*, p. 5.

⁴⁰⁷ *Ibid.*, p. 13.

⁴⁰⁸ International Committee of the Red Cross, *ICRC Report on the Treatment of Fourteen “High Value Detainees” in CIA Custody*, p. 13 (February 2007), <http://assets.nybooks.com/media/doc/2010/04/22/icrc-report.pdf> (accessed April 20, 2015).

⁴⁰⁹ International Committee of the Red Cross, *ICRC Report on the Treatment of Fourteen “High Value Detainees” in CIA Custody*, p. 13.

⁴¹⁰ *Ibid.*

by CIA agents, thrown to the floor after his clothes were forcibly removed, and that a suppository was forcibly inserted into his anus before being flown from Skopje Airport in Macedonia to Afghanistan.⁴¹¹ After arriving in Afghanistan, the CIA drove El-Masri in a vehicle for 10 minutes, then “dragged [him] from the vehicle, slammed [him] into the walls of a room, [threw him] to the floor, kicked and beat[] him. [...] Later, he understood that he had been transferred to a CIA-run facility.”⁴¹²

- Mohamed Farag Ahmad Bashmilah described a similar beating while held in CIA custody. He said he was turned over to the CIA in the early morning hours of October 26, 2003. After a short car ride to a building at the airport in Jordan, his clothes were cut off by black-clad, masked guards wearing surgical gloves. He was beaten. Bashmilah said one guard stuck a finger in his anus.⁴¹³
- Laid Saidi, who had been held by the CIA for 16 months, said CIA interrogators “beat me and threw cold water on me, spat at me, and sometimes gave me dirty water to drink.”⁴¹⁴

Sexual Abuse

At least three types of sexual abuse charges may apply to CIA actions under federal law. These include sexual abuse, aggravated sexual abuse, and abusive sexual contact. These provisions make it a crime to force anyone, while in a facility run by any federal department or agency or in the special maritime and territorial jurisdiction of the US, to engage in a sexual act or sexual contact.⁴¹⁵ A sexual act is defined to include, in relevant part, “the penetration, however slight, of the anal ... opening of another by a hand or finger or by any object, with an intent to abuse, humiliate, harass, [or] degrade.”⁴¹⁶ Sexual contact is defined to include: “intentional touching, either directly or through the clothing, of the

⁴¹¹ *El-Masri v. Former Yugoslav Republic of Macedonia*, (Application no. 39630/09), Judgment of 13 December 2012, available at <http://hudoc.echr.coe.int/sites/eng/pages/search.aspx?i=001-115621> (accessed April 20, 2015), para. 21, 40, 46, 124.

⁴¹² *El-Masri v. Former Yugoslav Republic of Macedonia*, (Application no. 39630/09), Judgment of 13 December 2012, available at <http://hudoc.echr.coe.int/sites/eng/pages/search.aspx?i=001-115621> (accessed April 20, 2015), para. 24.

⁴¹³ Mark Benjamin, “Inside the CIA’s Notorious ‘Black Sites,’” *Salon*, December 14, 2007, <http://www.salon.com/2007/12/15/bashmilah/> (accessed April 20, 2015).

⁴¹⁴ Craig S. Smith and Souad Mekhennet, “Algerian Tells of Dark Term in U.S. Hands,” *New York Times*, July 7, 2006, <http://www.nytimes.com/2006/07/07/world/africa/07algeria.html> (accessed April 20, 2015).

⁴¹⁵ 18 U.S.C. sec. 2241; sec. 2242; and sec. 2244. See discussion of meaning of special maritime and territorial jurisdiction of the US under 18 U.S.C. 113 in section of this report discussing the crime of assault above.

⁴¹⁶ 18 U.S.C. sec. 2246.

genitalia, anus, groin, breast, inner thigh, or buttocks of any person with an intent to abuse, humiliate, harass, [or] degrade.”⁴¹⁷

The CIA subjected at least five detainees to “rectal rehydration” and threatened several other detainees with the procedure.⁴¹⁸ “Rectal rehydration”—which in one case involved pureeing and rectally infusing a detainee’s meal of humus, pasta sauce, nuts and raisins—was done for the purpose of behavior control, not out of medical necessity.⁴¹⁹ A chief interrogator characterized the procedure as illustrative of the interrogator’s “total control over the detainee.”⁴²⁰ Another CIA official described the technique as helping to “clear a person’s head” and being effective at getting a detainee to talk.⁴²¹ One email describing the technique said “we used the largest Ewal [sic] tube we had.”⁴²² These statements suggest that the use of rectal rehydration was intended to abuse, harass, humiliate and degrade detainees, not for any legitimate medical purpose.

The Senate Summary indicates that CIA leadership, including General Counsel Scott Muller and CIA Deputy Director for Operations James Pavitt, was also alerted to allegations that rectal exams were conducted with “excessive force” on two detainees at detention site Cobalt in Afghanistan.⁴²³ An unidentified CIA attorney was asked to follow-up but CIA cables do not indicate there was any resolution.⁴²⁴ As noted above, one of the CIA detainees, Mustafa al-Hawsawi, was later diagnosed with chronic hemorrhoids, an anal fissure, and symptomaticrectal prolapse.⁴²⁵ Hawsawi is one of five detainees accused of playing a role in the September 11 attacks and is on trial at the military commissions at Guantanamo Bay. Since he was arraigned on the charges in May 2012, he has sat on a pillow throughout the proceedings.⁴²⁶ When asked about the

⁴¹⁷ 18 U.S.C. sec. 2246.

⁴¹⁸ Senate Summary, pp. 4 and 100.

⁴¹⁹ Senate Summary, p. 100, n. 584; See also “Medical Practitioners Denounce ‘Rectal Feeding’ as ‘Sexual Assault Masquerading as Medical Treatment,’” *Physicians for Human Rights*, https://s3.amazonaws.com/PHR_other/fact-sheet-rectal-hydration-and-rectal-feeding.pdf (accessed February 5, 2015).

⁴²⁰ Senate Summary, p. 82.

⁴²¹ Senate Summary, p. 83.

⁴²² Senate Summary, p. 100, n. 584.

⁴²³ Senate Summary, p. 100, n. 584.

⁴²⁴ *Ibid.*

⁴²⁵ *Ibid.*

⁴²⁶ Carol Rosenberg, “Senate report confirms CIA had ‘black site’ at Guantánamo, hid it from Congress,” *Miami Herald*, December 10, 2014, <http://www.miamiherald.com/news/nation-world/world/americas/guantanamo/article4434603.html> (accessed August 24, 2015).

details of what happened to his client, Walter Ruiz, Hawsawi's lawyer in the military commission proceedings, said that due to rules about classified information he was unable to discuss any facts that were not contained in the Senate Summary about his client's time in CIA custody.⁴²⁷ Some CIA detainees have also reported having suppositories forced into their anus.⁴²⁸ And other detainees have reported CIA operatives sticking fingers in their anus.⁴²⁹

Murder and Manslaughter

At least one detainee, Gul Rahman, died from hypothermia after being shackled overnight, half-naked, to a concrete floor at a CIA detention center in Afghanistan.⁴³⁰ Rahman was taken into custody in Pakistan on October 29, 2002 and died at the CIA detention site Cobalt, on November 20, 2002.⁴³¹ CIA records state that while he was in CIA custody he was subjected to "48 hours of sleep deprivation, auditory overload, total darkness, isolation, a cold shower, and rough treatment" without approval of these techniques in advance.⁴³² Several former CIA officials report that Rahman's "hands were shackled over his head" and "he was roughed up and doused with water."⁴³³ The Senate Summary states that "dehydration, lack of food, and immobility due to 'short chaining,'" were also factors that contributed to Rahman's death.⁴³⁴

Another detainee, Manadel al-Jamadi, also died just over five hours after his arrest while undergoing a CIA-led interrogation.⁴³⁵ A plastic bag had been placed over his head and he

⁴²⁷ Human Rights Watch email exchange with Walter Ruiz, August 24, 2015. See also section on "Classifying Information about CIA Torture" below.

⁴²⁸ *El-Masri v. Former Yugoslav Republic of Macedonia*, (Application no. 39630/09), Judgment of 13 December 2012, available at <http://hudoc.echr.coe.int/sites/eng/pages/search.aspx?i=001-115621> (accessed April 20, 2015), para. 21, 40, 46, 124. See *Delivered into Enemy Hands*, p. 36, n. 123.

⁴²⁹ Craig S. Smith and Souad Mekhennet, "Algerian Tells of Dark Term in U.S. Hands," *New York Times*, July 7, 2006, <http://www.nytimes.com/2006/07/07/world/africa/07algeria.html> (accessed April 20, 2015).

⁴³⁰ Senate Summary, p. 54.

⁴³¹ Senate Summary, p. 54. See also, Adam Goldman and Kathy Gannon, "Death Shed Light on CIA 'Salt Pit,' Near Kabul," *Associated Press*, March 28, 2010, http://www.nbcnews.com/id/36071994/ns/us_news-security/t/death-shed-light-cia-salt-pit-near-kabul/ (accessed November 13, 2015). Detention site Cobalt is widely believed to have been the same as what many called the Salt Pit before the Senate Summary used the pseudonym Cobalt for it.

⁴³² Senate Summary, p. 54.

⁴³³ Goldman and Gannon, "Death Shed Light on CIA 'Salt Pit,' Near Kabul," *Associated Press*.

⁴³⁴ Senate Summary, p. 55, n. 272.

⁴³⁵ John McChesney, "The Death of an Iraqi Prisoner," *NPR*, October 27, 2005, <http://www.npr.org/templates/story/story.php?storyId=4977986> (accessed April 19, 2015).

was shackled with his arms behind him to a barred window five feet off the ground.⁴³⁶ Military investigators deemed it a homicide due to “blunt force trauma” to the head and torso “complicated by compromised respiration” and five broken ribs.⁴³⁷ Both cases were included in the Durham investigation into CIA abuses (see above) but al-Jamadi’s case was not included in the Senate Summary.⁴³⁸ The reason it was not included is unclear, but it is possibly because his death occurred at Abu Ghraib, a military base, not at a CIA detention center, and there was some military participation.⁴³⁹ No criminal charges were ever brought in either case yet the publicly available facts indicate that either manslaughter or murder charges were viable in both cases.⁴⁴⁰ Though the statute of limitations would likely bar charges for manslaughter today, charges for murder could still be brought since it is a capital crime and therefore not subject to a statute of limitations (see below).

War Crimes

Charges may be available under the US War Crimes Act of 1996.⁴⁴¹ The act provides criminal punishment for whomever, inside or outside the US, commits a war crime, if either the perpetrator or the victim is a member of the US Armed Forces or a national of the United States.⁴⁴² A “war crime” is defined as any “grave breach” of the 1949 Geneva Conventions or acts that violate article 3 common to the four Geneva Conventions of 1949

⁴³⁶ Jane Mayer, “A Deadly Interrogation,” *The New Yorker*, November 14, 2005,

<http://www.newyorker.com/magazine/2005/11/14/a-deadly-interrogation> (accessed April 19, 2015).

⁴³⁷ McChesney, “The Death of an Iraqi Prisoner,” *NPR*. Mayer, “A Deadly Interrogation,” *The New Yorker*; See also The Constitution Project, p. 96, summarizing these two reports.

⁴³⁸ Peter Finn and Julie Tate, “Justice Department to investigate deaths of two detainees in CIA custody,” *Washington Post*, July 1, 2011, http://www.washingtonpost.com/politics/federal-prosecutor-probes-deaths-of-2-cia-held-detainees/2011/06/30/AGsFmUsH_story.html (accessed June 30, 2015); Jason Ryan, “DOJ: No Charges in CIA Detainee Death Investigations,” *ABC News*, August 30, 2012, <http://abcnews.go.com/Blotter/doj-charges-cia-detainee-death-investigations/story?id=17119715> (accessed June 30, 2015).

⁴³⁹ The military charged Navy SEAL Lt. Andrew Ledford with dereliction of duty for allowing his men to punch and jab al-Jamadi with their rifle muzzles and assault for punching al-Jamadi himself. He was acquitted of all charges. See John McChesney, “Navy SEAL Cleared of Prisoner Abuse in Iraq,” *NPR*, May 8, 2005, <http://www.npr.org/templates/story/story.php?storyId=4670936> (accessed April 19, 2015).

⁴⁴⁰ See 18 U.S.C. sec. 1111. Malice, as defined for purposes of second degree murder, under 18 U.S.C. sec. 1111(a) can include the mental state of either: “intent to do serious bodily injury” or “depraved heart recklessness,” *United States v. Visinaiz*, 428 F.3d 1300, 1307 (10th Cir. Utah 2005). “Proof of the existence of malice for second degree murder does not require a showing that the accused harbored hatred or ill will against the victim or others. Neither does it require proof of an intent to kill or injure. Malice may be established by evidence of conduct which is ‘reckless and wanton and a gross deviation from a reasonable standard of care, of such a nature that a jury is warranted in inferring that defendant was aware of a serious risk of death or serious bodily harm.’” *United States v. Fleming*, 739 F.2d 945, 947-948 (4th Cir. Va. 1984)(citations omitted). 18 U.S.C. sec. 1111 also requires that the crime be committed in the special maritime and territorial jurisdiction of the United States. For discussion of the meaning of special maritime and territorial jurisdiction see section discussing the crime of assault under 18 U.S.C. 113 (above).

⁴⁴¹ *Getting Away With Torture*, p. 49.

⁴⁴² War Crimes Act of 1996, Pub.L. 104–192, 18 U.S.C. sec. 2441.

(Common Article 3). Grave breaches include “willful killing, torture or inhuman treatment” of prisoners of war and of civilians qualified as “protected persons.” Common Article 3 prohibits murder, mutilation, cruel treatment and torture, and “outrages upon personal dignity, in particular humiliating and degrading treatment.”

The 2006 Military Commissions Act revised the War Crimes Act and limited the definition of war crimes, with retroactive effect.⁴⁴³ As a result, humiliating and degrading treatment of detainees in US counterterrorism operations following the September 11 attacks can no longer be charged as a war crime under the statute.⁴⁴⁴ However, the Military Commissions Act did not change liability for murder, rape, sexual assault, and torture.⁴⁴⁵

Defenses

Statutes of Limitations

Though much of the torture and other abuse took place many years ago, many of the available charges are not barred by statutes of limitation.⁴⁴⁶ The statute of limitations for most federal crimes is five years,⁴⁴⁷ but there are several exceptions to this rule that are applicable to the facts described above.

Capital Offenses

There is no statute of limitations for capital offenses, which include torture that result in death.⁴⁴⁸ In at least two cases, the CIA’s use of interrogation techniques contributed to death.⁴⁴⁹

⁴⁴³ Military Commissions Act of 2006, Pub.L. 109-366, 10 U.S.C. 948-949 (2006); War Crimes Act of 1996, Pub. L. 104-192, 18 U.S.C. sec. 2441 (2006).

⁴⁴⁴ “Human Rights Watch, “Q & A: Military Commissions Act of 2006,” section 16, <https://www.hrw.org/legacy/backgrounders/usa/qna1006/>

⁴⁴⁵ *Getting Away With Torture*, p. 49.

⁴⁴⁶ This statute of limitations analysis does not address attempts, or aiding and abetting.

⁴⁴⁷ Offenses Not Capital, 18 U.S.C. sec. 3282(a).

⁴⁴⁸ Capital Offenses 18 U.S.C. sec. 3281, see also 18 U.S.C. 2340A(a) authorizing punishment by death under the statute for torture that results in death and 18 U.S.C. 1201(a)(5) which authorizes punishment by death if death results from the kidnapping. Human Rights Watch opposes the death penalty in all circumstances as an inherently cruel and irrevocable punishment.

⁴⁴⁹ See Murder and Manslaughter sections below.

Offenses Leading to Serious Risk of Bodily Injury or Risk of Death

The USA Patriot Act expanded the statute of limitations for a specific list of offenses from five to eight years.⁴⁵⁰ Torture, as well as conspiracy to torture and conspiracy to kidnap persons abroad, are crimes that are included on that list.⁴⁵¹ While many of the offenses described above were committed more than eight years ago, the statute of limitations may well have been tolled (or extended), as discussed below.

In addition, when the commission of one of the offenses results in death or *creates a foreseeable risk of death or serious bodily injury*, there is no statute of limitations.⁴⁵²

Many of the CIA abuses and potential charges described above fit the category of offenses that create a foreseeable risk of death or serious bodily injury.⁴⁵³ As previously noted, in at least one case, the CIA's use of torture resulted in death. In other cases, detainees came close to dying or it was clear they would suffer other long-term injuries.

⁴⁵⁰ P.L. 107-56, 115 sec. 809 (2001); see also the law codified at 18 U.S.C. sec. 3286(a), listing, among others, any provision in section 2332b(g)(5)(B) as those crimes for which the statute of limitations is extended to eight years.

⁴⁵¹ See Federal Law 18 U.S.C. sec. 3286(a) applying a statute of limitation of eight years for any offense listed in Federal Law 18 U.S.C. sec. 2332b(g)(5)(B), which includes the crimes of conspiracy to kidnap under 18 U.S.C. sec. 956(a)(1) as well as torture and conspiracy to torture under 18 U.S.C. 2340A(a) and (c).

⁴⁵² See 18 U.S.C. sec. 3286(b) stipulating no statute of limitation for offenses listed in section 2332b(g)(5)(B) if the commission of such offense resulted in, or created a foreseeable risk of, death, or serious bodily injury to another person. Though the list of offenses to which this statute of limitation exception applies are called "terrorism offenses" in the statute, there is no requirement that they meet the definition of the term "Federal crime of terrorism" in section 2332b(g)(5)(A) and (B), just that they are one of the enumerated offenses in section 2332b(g)(5)(B). Rather it appears that an offense must meet both requirements in 2332b(g)(5)(A) and (B) in order to be considered a "Federal crime of terrorism" for sentencing enhancement purposes. The US government took the same position in *Nezirovic v. Holt*, United States District Court for the Western District of Virginia, Roanoke Division, 990 F. Supp. 2d 606, March 13, 2014. In *Nezirovic*, the government of Bosnia sought Nezirovic's extradition for allegations that he had abused unarmed civilian prisoners during the Bosnian war. Specifically, he was accused of among other things, beating them with batons, threatening them with death, forcing them to remove their clothes and crawl on the ground, to put their noses in others' anuses, and to eat grass on which others had urinated. Under the extradition treaty, extradition would have been barred if the applicable statute of limitations for the same crime in the US, the crime of torture, had expired. The US government took the position in the case that there was no bar to extradition because as one of the enumerated offenses under 18 U.S.C. 2332b(g)(5)(B), there was no statute of limitation for the crime of torture under 2340A when the charged offense resulted in or created a foreseeable risk of death or serious bodily injury. The court agreed. *Nezirovic*, p. 613. See also US government brief in *Nezirovic* which supports this reading of the statute. Brief for Respondent-Appellee (January 03, 2014) at pp. 18-19, *Nezirovic v. Holt et al.*, 990 F.Supp. 2d 606 (2014) (7:13CV00428). See also Charles Doyle, "Statutes of Limitations in Federal Criminal Cases: An Overview," *Congressional Research Service*, October 1, 2012, <https://www.fas.org/sgp/crs/misc/RL31253.pdf> (accessed October 25, 2015), p. 2, n. 18 (Although the crimes [enumerated in 18 U.S.C. 2332b(g)(5)(B)], were selected because they are often implicated in acts of terrorism, a terrorist defendant is not a prerequisite to an unlimited period for prosecution").

⁴⁵³ "Serious bodily injury" is defined as meaning "bodily injury which involves— (A) a substantial risk of death; (B) extreme physical pain; (C) protracted and obvious disfigurement; or (D) protracted loss or impairment of the function of a bodily member, organ, or mental faculty." See section 18 U.S.C. sec. 2332(b)(g)(3) which states, as used in this section, the term "serious bodily injury" has the meaning given that term in section 1265(g)(3). "Serious bodily injury" is not defined however in 1365(g)(3) but it is defined in the next subsection, 18 U.S.C. § 1365(h)(3).

In contemplating the very first use of the approved “enhanced interrogation techniques” on Abu Zubaydah, who had been shot three times during his capture and was reportedly close to death,⁴⁵⁴ CIA officers at the detention site where he was held wrote:

If [Abu Zubaydah] develops a serious medical condition which may involve a host of conditions including a heart attack or another catastrophic type of condition all efforts will be made to ensure that proper medical care will be provided to [him]. In the event that [Abu Zubaydah] dies, we need to be prepared to act accordingly, keeping in mind the liaison equities involving our hosts.⁴⁵⁵

The memo went on to note that if Abu Zubaydah died, he would be cremated, but “regardless In light of the planned psychological pressure techniques to be implemented, we need to get reasonable assurances that [he] will remain in isolation and incommunicado for the remainder of his life.”⁴⁵⁶ One application of the waterboarding technique on Abu Zubaydah was so physically harmful that it induced convulsions and vomiting.⁴⁵⁷ He later became completely “unresponsive, with bubbles rising through his open, full mouth.”⁴⁵⁸

Another detainee was subjected to the CIA’s “water-dousing”⁴⁵⁹ technique during which a CIA officer poured cold icy water directly on the detainee’s face “to disrupt his breathing.”⁴⁶⁰ The detainee “turned blue” and a physician’s assistant intervened, removing the cloth over the detainee’s mouth so he could breathe.⁴⁶¹

⁴⁵⁴ Scott Shane, “Inside a 9/11 Mastermind’s Interrogation,” *New York Times*, June 22, 2008, http://www.nytimes.com/2008/06/22/washington/22ksm.html?pagewanted=all&_r=0 (accessed April 21, 2015).

⁴⁵⁵ Senate Summary, pp. 34-35.

⁴⁵⁶ Senate Summary, p. 35.

⁴⁵⁷ Senate Summary, p. 41.

⁴⁵⁸ Senate Summary, pp. 43-44.

⁴⁵⁹ For a definition of “water dousing” and explanation of how it was applied, see the “Waterboarding and Water Dousing” section of this report above.

⁴⁶⁰ Senate Summary, p. 107.

⁴⁶¹ Senate Summary, p. 107. A linguist apparently reported this incident to the CIA inspector general. It was later referred to the Justice Department for criminal investigation but not pursued, a CIA inspector general report concluded, because the linguist’s claims could not be corroborated. The detainee, Khalid Sharif, who went by the name of Abu Hazim at the time he was in CIA custody, (the name the Senate Summary uses) was interviewed for Human Rights Watch for the report *Delivered into Enemy Hands* several times in 2012. At that time he said that no US government personnel ever interviewed him for any criminal investigation regarding this abuse or any other abuse he suffered while in CIA custody. Had they done so, the account could have been corroborated.

In another case, two detainees with broken feet were forced to stand and walk on their injured legs for days while being subjected to standing sleep deprivation, despite a medical examiner recommending that they not put any weight on their broken bones for, in the case of one detainee, five weeks and in the case of another detainee, for three months.⁴⁶² With regard to one of the detainees, a CIA cable drafted days later stated that, “even given the best prognosis,” the detainee would have “arthritis and limitation of motion for the rest of his life.”⁴⁶³

Sexual Abuse

There is no statute of limitations for certain types of sexual abuse crimes.⁴⁶⁴ These include the three charges discussed above as potentially applicable to “rectal rehydration”: sexual abuse, aggravated sexual abuse, and abusive sexual contact.

Special Case of Conspiracy

Conspiracy, like most federal crimes, is subject to a five-year statute of limitations. But it is distinct from other offenses in that it is a continuing crime that does not end until the last co-conspirator commits the last overt act of the conspiracy.⁴⁶⁵

Normally, actions taken by co-conspirators to hide crimes after they are committed are not considered part of the conspiracy. However, where concealment is a central component of the purpose of the conspiracy—as appears to be the case here—the limitation period may be extended until the date of the last act or attempted act of concealment.⁴⁶⁶

⁴⁶² Senate Summary, pp. 491-92.

⁴⁶³ Senate Summary, pp. 491-92.

⁴⁶⁴ Limitations: Child Abduction and Sex Offenses 18 U.S.C. §3299 which states “Notwithstanding any other law, an indictment may be found or an information instituted at any time without limitation ... for any felony under Chapter 109A...” The felonies in Chapters 109A include violations of 18 U.S.C. §2241 (aggravated sexual abuse), §2242 (sexual abuse), and §2244 (abusive sexual contact).

⁴⁶⁵ *Fiswick v. United States*, 329 U.S. 211, 216 (1946).

⁴⁶⁶ *Grunewald v. United States*, 353 U.S. 391, 405 (1957). “Grunewald drew a distinction between ‘acts of concealment done in furtherance of the main objectives of the conspiracy,’ and ‘acts of concealment done after these central objectives have been attained for the purposes of covering up after the crime.’ Where the latter is involved, the government must present some proof of an express original agreement to engage in the acts of concealment. However, nothing in the case law imposes a requirement that conspirators expressly agree to engage in acts of concealment where those acts are done in furtherance of the main objectives of the conspiracy. Rather, the acts of concealment committed by one co-conspirator need only have been ‘foreseeable’ to the other co-conspirator.” *United States v. Upton*, 559 F.3d 3, 14 (1st Cir. Mass. 2009) (citations omitted).

On the facts at issue here, if prosecutors charged conspiracy using the stand-alone conspiracy statute, one of the central components of the conspiracy would be the process by which various officials sought to generate legal cover, or “authorization” for the use of “enhanced interrogation techniques,” knowing those techniques were unlawful. Ongoing attempts on the part of senior White House, CIA, or other officials to conceal their involvement in manufacturing the legal cover for torture can be considered an overt act in furtherance of the conspiracy that works to extend the five-year statute of limitations. The concealment continues to this day. As recently as December 11, 2014, two days after the SSCI report was released, former Vice President Dick Cheney reiterated the importance of OLC approval for the techniques, as if OLC approval were an independent act and not itself part of the conspiracy to commit torture: “Torture is something we very carefully avoided.... All of the techniques that were authorized by the president were, in effect, blessed by the Justice Department opinion that we could go forward with those without, in fact, committing torture.”⁴⁶⁷

Concealment of the central component of the conspiracy, to the extent that it took place, could work to toll any statute-of-limitations issues until the present, or at least very recently. The same is true for other attempts, well documented in the Senate Summary, to keep the nature, extent and effectiveness of the abuses from the public and prosecutors.⁴⁶⁸

In addition, it is unclear whether the Department of Justice had full access to relevant CIA and White House records as part of the Durham inquiry—or does even today. Indeed, Senate Intelligence Committee staff drafting the report never had full access to White House or CIA files as they relate to the CIA program. The CIA asserted executive privilege on behalf of the White House in relation to more than 9,400 documents that the Senate Intelligence Committee requested for their report.⁴⁶⁹ The CIA also refused to provide a copy of an internal review of the CIA’s program (often referred to as the “Panetta Report” after then CIA director Leon Panetta) to

⁴⁶⁷ Interview with former Vice President Dick Cheney, “Meet the Press Transcript - December 14, 2014,” <http://www.nbcnews.com/meet-the-press/meet-press-transcript-december-14-2014-n268181> (accessed January 12, 2015).⁴⁶⁸ See, e.g., finding and conclusion number 3 of the Senate Summary titled: “The interrogations of CIA detainees were brutal and far worse than the CIA represented to policymakers and others,” Senate Summary, pp. 3-4.

⁴⁶⁸ See, e.g., finding and conclusion number 3 of the Senate Summary titled: “The interrogations of CIA detainees were brutal and far worse than the CIA represented to policymakers and others,” Senate Summary, pp. 3-4.

⁴⁶⁹ Jonathan Landay, Ali Watkins, and Marisa Taylor, “White House withholds thousands of documents from Senate CIA probe, despite vows of help,” *McClatchy*, March 12, 2014, <http://www.mcclatchydc.com/2014/03/12/221033/despite-vows-of-help-white-house.html#storylink=cpy> (accessed January 20, 2015).

the Senate Intelligence Committee.⁴⁷⁰ In the event that prosecutors had full and immediate access to all CIA files on August 29, 2009 when the investigation was announced, the statute of limitations might bar prosecution under the general conspiracy statute, section 371, but it would not bar prosecution for torture, conspiracy to torture under section 2340A(c), or conspiracy to kidnap under section 956 both of which have an eight year statute of limitations and no statute of limitation when a foreseeable risk of death or serious bodily injury may result.

“Good Faith” Reliance on Counsel

As noted above, Bush, Cheney, and others have asserted that in implementing the program, they were merely relying on OLC’s guidance that the techniques being employed by the CIA were lawful.⁴⁷¹ This suggests officials might invoke a defense of a “good faith” reliance on counsel to any criminal charges brought. But such a defense would be weak as applied to these facts.

Under US law an accused person generally cannot invoke an “advice-of-counsel” or “mistake-of-law” defense.⁴⁷² As Judge Richard Posner has noted, “If unreasonable advice of counsel could automatically excuse criminal behavior, criminals would have a straight and sure path to immunity.”⁴⁷³ However, advice of counsel can be relevant to certain elements of crimes, such as a requirement of knowledge or willfulness.⁴⁷⁴ For example, as one case notes:

Reliance on counsel's advice excuses a criminal act only to the extent it negates willfulness and to negate willfulness counsel's advice must create (or perpetuate) an honest misunderstanding of one's legal duties. If a person is

⁴⁷⁰ Mark Mazzetti, “Behind Clash Between C.I.A. and Congress, a Secret Report on Interrogations,” *New York Times*, March 7, 2014, <http://www.nytimes.com/2014/03/08/us/politics/behind-clash-between-cia-and-congress-a-secret-report-on-interrogations.html> (accessed January 20, 2015).

⁴⁷¹ See, e.g., “Matt Lauer interviews Bush about 9/11,” *NBC News*, September 11, 2006, <http://www.nbcnews.com/video/nbc-news/14781377#14781377> (accessed April 20, 2015) (at minute 8:20, Lauer: “Were you made personally aware of all the techniques that were used for example against Khalid Sheikh Mohammed, and did you approve those techniques?” Bush: “I told our people, get information without torture and was assured by our Justice Department that we were not torturing...Whatever we have done is legal, that is what I’m saying, it’s within the law. We had lawyers look at and say, Mr. President, this is lawful.”); “Transcript: Cheney Defends Hard Line Tactics,” *ABC News*, December 16, 2008, <http://abcnews.go.com/print?id=6464697> (accessed April 20, 2015) (“Again, we proceeded very cautiously. We checked. We had the Justice Department issue the requisite opinions in order to know where the bright lines were that you could not cross. The professionals involved in that program were very, very cautious, very careful—wouldn’t do anything without making certain it was authorized and that it was legal. And any suggestion to the contrary is just wrong.”).

⁴⁷² *United States v. Sprong*, 287 F.3d 663, 665 (7th Cir. Wis. 2002) and *United States v. Benson*, 941 F.2d 598, 613 (7th Cir. Ill. 1991).

⁴⁷³ *Sprong*, p. 665.

⁴⁷⁴ *Sprong*, p. 665, *Benson*, p. 613.

told by his attorney that a contemplated course of action is legal but subsequently discovers the advice is wrong or discovers reason to doubt the advice, he cannot hide behind counsel's advice to escape the consequences of his violation.⁴⁷⁵

However, a portion of the 2005 Detainee Treatment Act, which was drafted after the Abu Ghraib revelations and the release of the Torture Memos, provides that in any criminal prosecution arising out of a US person's or other agent's engagement in operational practices involving the detention and interrogation of individuals:

that were officially authorized and determined to be lawful at the time that they were conducted, it shall be a defense that ... [the] agent did not know that the practices were unlawful and a person of ordinary sense and understanding would not know the practices were unlawful. Good faith reliance on advice of counsel should be an important factor, among others, to consider in assessing whether a person of ordinary sense and understanding would have known the practices to be unlawful.⁴⁷⁶

This statutory defense applies only to “officially authorized” conduct that was “determined to be lawful at the time.” In this case, the defense would center on the question of whether it was reasonable to believe that the CIA practices were lawful and if reliance on the advice of counsel was made in “good faith.” If so, even under section 1004(a), good faith reliance would not be a complete defense but it would be an “important factor ... to consider” in assessing whether a person should have known the practices were unlawful.

This defense is weak for the following reasons:

First, it was not reasonable to believe these practices were lawful. As mentioned above, the techniques themselves were derived from the SERE program—a program designed to

⁴⁷⁵ *United States v. Benson*, 941 F.2d 598, 614 (7th Cir. Ill. 1991).

⁴⁷⁶ Detainee Treatment Act of 2005, Public Law 163-109, 119 Stat. 3136, January 6, 2006, Section 1004(a), codified at 42 U.S.C. §2000dd-1(a) <http://www.dni.gov/index.php/about/organization/ic-legal-reference-book-2012/ref-book-detainee-treatment-act-of-2005> (accessed August 18, 2015). This act, among other things, also prohibited “cruel, inhuman and degrading treatment or punishment,” of persons in the custody of the US government, and required Department of Defense personnel to employ United States Army Field Manual guidelines when interrogating detainees.

train US special forces to endure interrogation methods used by enemies who did not abide by the Geneva Conventions; many of the techniques were already banned by the US Army Field Manual in effect at the time—a manual that describes many of the techniques as torture; and the FBI refused to participate in the program. It is reasonable that people involved should have questioned the legality of the practices. Moreover, the extensive discussion about whether the CIA was engaging in “humane” practices reveals that CIA officials concern about whether they should be engaging in the practices at all, even after they were “authorized.”

Second, reliance on counsel was not “in good faith.” As mentioned above, before the OLC memos were produced, the CIA and senior officials already knew that courts would almost certainly find many of the authorized techniques illegal. That is why they sought a guarantee not to prosecute from the Department of Justice Criminal Division, which refused to provide it, and very likely why the FBI refused to participate in the CIA’s detention and interrogation program. Only after these rejections did Yoo add arguments to the memos about the specific intent requirement, commander-in-chief powers, and defenses to prosecution. The evidence suggests that this was done at the request of senior officials at the White House and the CIA who were concerned about the illegality of the techniques and looking for legal cover. As one legal scholar put it: “When considered as a whole, the memos reveal a sustained effort by the OLC lawyers to rationalize a predetermined and illegal result.”⁴⁷⁷ This alone suggests that any reliance was not in good faith. But numerous other signs along the way, such as Abu Zubaydah’s waterboarding sessions, which generated concerns about illegality from CIA officers, provide further evidence.⁴⁷⁸

Finally, the statutory defense is only available to those who engaged in “specific operational practices” in connection with detention and interrogation activity. It should therefore not be available to those involved in authorizing the program. It also should not be available to those who engaged in practices that went beyond what where authorized. This would include applying techniques in a manner inconsistent or in excess with authorizations or doing so without getting prior approval as required.

⁴⁷⁷ David Cole, “The Torture Memos: The Case Against the Lawyers,” *The New York Review of Books*, October 8, 2009 <http://www.nybooks.com/articles/archives/2009/oct/08/the-torture-memos-the-case-against-the-lawyers/> (accessed January 28, 2015).

⁴⁷⁸ Senate Summary, p. 44.

III. Repairing the Harm and Ending Torture

Obligation to Provide Redress, Compensation, and Rehabilitation

The Convention against Torture, in addition to obligating states to investigate and appropriately prosecute torture and other ill-treatment, requires them to provide redress to victims of torture and ensure that they have “an enforceable right to fair and adequate compensation.”⁴⁷⁹ This should include the means to obtain full rehabilitation to the extent possible, as well as compensation to dependents when a torture victim is deceased.⁴⁸⁰

As a party to the International Covenant on Civil and Political Rights (ICCPR), the United States is also obligated to “give effect to the rights” recognized by the treaty, including when those rights have been violated “by persons acting in an official capacity.”⁴⁸¹ Specifically, the US is treaty-bound to provide an “effective remedy,” including a “judicial remedy,” and to ensure that competent authorities “enforce such remedies when granted.”⁴⁸²

In addition to torture and ill-treatment, the ICCPR prohibits arbitrary arrest and detention, and requires states, at minimum, to provide those detained with the ability to challenge the lawfulness of detention before a court.⁴⁸³ The ICCPR specifically requires that those who are the “victim of unlawful arrest or detention shall have an enforceable right to compensation.”⁴⁸⁴

Harms from Arbitrary Detention, Torture, and Ill-Treatment

The CIA program had both short-term and long-term physical and psychological effects on detainees. Techniques such as suspension of the arms causes musculoskeletal pain, chronic severe headaches, numbness and weakness in the arms. Constant exposure to loud music causes hearing loss. And prolonged stress positions result in back pain and numbness in the

⁴⁷⁹ Convention against Torture, art. 14 (“Each State Party shall ensure in its legal system that the victim of an act of torture obtains redress and has an enforceable right to fair and adequate compensation including the means for as full rehabilitation as possible. In the event of the death of the victim as a result of an act of torture, his dependents shall be entitled to compensation.”).

⁴⁸⁰ *Ibid.*

⁴⁸¹ ICCPR, arts. 2(2) and 2(3).

⁴⁸² ICCPR, art. 2(3).

⁴⁸³ ICCPR, arts. 7 and 9(1)-(4)

⁴⁸⁴ ICCPR, art. 9(5).

legs.⁴⁸⁵ Former detainees subjected to CIA interrogation techniques reported lasting mental health effects such as depression, anxiety, sleeplessness, post-traumatic stress disorder, feelings of hopelessness, sadness, isolation, bouts of weeping, panic attacks, nervous or explosive reactions to minor problems, memory loss, and flashbacks.⁴⁸⁶

Detainees in CIA custody were also subjected to long-term incommunicado detention, which itself can amount to a form of torture.⁴⁸⁷ For their families it brought the considerable stress of not knowing the whereabouts of their relatives or even whether they were alive or dead.

One Family's Suffering

Mohammed Shoroeyiya's wife Fawziya had no knowledge of her husband's whereabouts after US and Pakistani forces took him into custody during a raid on their home in Peshawar Pakistan in March 2003. She did not know that US forces sent Shoroeyiya to two different "black sites" where he was detained for 16 months.⁴⁸⁸ The US then rendered Shoroeyiya back to Libya, a country from which he had fled 15 years earlier and where he feared he would be tortured, perhaps killed. It was only at this point, in August 2004, that Libyan authorities informed Fawziya that her husband was alive.⁴⁸⁹ The Libyan government then transported Fawziya and their daughter Aisha back to Libya from Pakistan. However, Shoroeyiya, a known opponent of Libyan leader Muammar Gaddafi, remained imprisoned

⁴⁸⁵ International Center for Transitional Justice, "U.S. Accountability and the Right to Redress," August 2010, <https://www.ictj.org/sites/default/files/ICTJ-USA-Right-Redress-2010-English.pdf> (accessed April 27, 2015), p. 19 (hereinafter "ICTJ Accountability and Redress Report"), summarizing findings of a number of other reports documenting the effects of abuse, torture and long-term arbitrary and incommunicado detention on former US detainees held in Iraq, Guantanamo, and Afghanistan including: Physicians for Human Rights, "Broken Laws, Broken Lives: Medical Evidence of Torture by the US," June 2008; Human Rights Watch, "Guantanamo: Detainee Accounts," 2004, <http://www.hrw.org/legacy/backgrounders/usa/gitmo1004/gitmo1004.pdf> (accessed April 28, 2015), pp. 23-24; Human Rights Watch, "Locked up and Alone: Detention Conditions and Mental Health at Guantanamo," June 2008, http://www.hrw.org/sites/default/files/reports/uso608_1.pdf (accessed April 28, 2015). The report also cites several detainee accounts from complaints in civil cases brought against US government officials for abuse in US detention.

⁴⁸⁶ ICTJ Accountability and Redress Report, p. 19.

⁴⁸⁷ See, for example, UN, "UN Special Rapporteur on torture calls for the prohibition of solitary confinement," October 18, 2011, <http://www.ohchr.org/en/NewsEvents/Pages/DisplayNews.aspx?NewsID=11506&LangID=E#sthash.S2GG11cj.dpuf> (accessed September 28, 2015). The US has recognized prolonged incommunicado detention as torture. See, for example, US Department of State, "Human Rights Report: China," March 31, 2003, <http://www.state.gov/j/drl/rls/hrrpt/2002/18239.htm> (accessed September 28, 2015).

⁴⁸⁸ *Delivered Into Enemy Hands*, pp. 34-58.

⁴⁸⁹ *Ibid.*, pp. 56-58.

in Libya for another seven years. He was only released in 2011, along with other political prisoners in Gaddafi's jails, during the Libyan uprising of 2011. While her husband was in US and Libyan custody, Fawziya relied on the good will of neighbors and family to survive.⁴⁹⁰ "One day they just came and took him. I didn't know what to do," Fawziya said. "I had nothing, all I had were prayers, and they told us nothing."⁴⁹¹ Shoroeiya said knowing the impact his absence had on his wife and child was the hardest thing about being detained, harder than the torture:

The biggest suffering for any prisoner like myself was the situation with our families. When my daughter comes to me and says they prevented her from going to school or my wife comes to me and says she doesn't have a dime to spend, that is suffering. You asked me about the physical abuse. That was number 10 on the list of the worst things that I was going through.⁴⁹²

Many other families were left without their main breadwinner and suffered severe economic hardship. After the US released men it had detained from detention, many reported having problems adjusting to normal life, difficulty finding jobs, and problems coping with the stigma associated with their prior detention.⁴⁹³

US Failure to Comply with International Legal Obligations

Failure to Provide Compensation

Compensation can provide victims and their family members with the means to address the lasting impact of human rights violations. These can include loss of employment opportunities, education, social benefits, earning potential, harm to reputation, costs required for legal assistance, and medical, psychological and social services.⁴⁹⁴

Compensation, of course, is not a substitute for investigations and appropriate prosecutions, and does not address many government obligations under the Convention against Torture.⁴⁹⁵

⁴⁹⁰ Ibid., pp. 56-58.

⁴⁹¹ Human Rights Watch Interview with Fawziya, Misrata, Libya, March 27, 2012.

⁴⁹² *Delivered Into Enemy Hands*, p. 58.

⁴⁹³ ICTJ Accountability and Redress Report, p. 20.

⁴⁹⁴ Ibid., p. 21.

⁴⁹⁵ CAT, General Comment No. 3, paras. 9-10.

It can be expected that there would be significant political resistance in the United States to providing compensatory redress to former detainees because of the belief that the US “war on terror” justified the government’s actions, that those detained were involved in terrorism even if not prosecuted for the crime, and that any compensation provided could be misused for terrorist activities. Such arguments do not take into account that many detainees were taken into custody unlawfully even by the CIA’s own standards, that those involved in terrorist acts remain protected under international law against torture and other ill-treatment, and that measures can be put in place to prohibit funds from being used for illegal purposes.⁴⁹⁶ Moreover, providing compensation would go a long way in helping deflate anger against the United States in many countries around the world. Regardless of the extent of these practical benefits, however, US treaty obligations require that compensation and other redress be provided without discrimination, regardless of why the person entitled to redress was detained, including whether that person was accused of terrorist acts.⁴⁹⁷

US Obstruction of a Right to a Remedy

In reporting to the UN Committee against Torture in 2013 about its compliance with treaty obligations, the US stated that “various avenues” exist and a “wide range of civil remedies” are available to victims of torture to obtain redress.⁴⁹⁸ Yet virtually no individual who has brought suit against US personnel or civilian contractors working for the US government with valid claims of CIA or US military post-9/11 torture have ultimately prevailed in court.

⁴⁹⁶ At least 26 detainees in the CIA program were “wrongfully held,” and did not meet the CIA’s own standards for detention. CIA records provide insufficient information to justify the detention of many more. Senate Summary, Findings and Recommendations, p. 12.

⁴⁹⁷ UN Committee against Torture, General Comment No. 3, “Implementation of Article 14 by States Parties,” http://www1.umn.edu/humanrts/cat/general_comments/cat_gen_com3.html (accessed July 1, 2015), para. 32; see also UN Human Rights Committee, “Basic Principles and Guidelines on the Right to a Remedy and Reparation for Victims of Gross Violations of International Human Rights Law and Serious Violations of International Humanitarian Law,” General Assembly Resolution 60/147 of 16 December 2005, <http://www.ohchr.org/EN/ProfessionalInterest/Pages/RemedyAndReparation.aspx> (accessed April 28, 2015) (hereinafter “Basic Principles”), para. 8; UN Committee against Torture, General Comment No. 2, U.N. Doc. CAT/C/GC/2 (January 28, 2008), http://tbinternet.ohchr.org/_layouts/treatybodyexternal/Download.aspx?symbolno=CAT%2fC%2fGC%2f2&Lang=en, para. 21. See also, UN Human Rights Committee, General Comment No. 18, Non-discrimination, U.N. Doc. HRI/GEN/1/Rev.1 (1994), http://tbinternet.ohchr.org/_layouts/treatybodyexternal/Download.aspx?symbolno=INT%2fCCPR%2fGEC%2f6622&Lang=en (accessed August 24, 2015).

⁴⁹⁸ “US Government, Consideration of reports submitted by States parties under article 19 of the Convention pursuant to the optional reporting procedure, Third to fifth periodic reports of States parties due in 2011,” United States of America, CAT/C/USA/3-5, <http://www.state.gov/documents/organization/213267.pdf> (accessed April 27, 2015), para. 147 (also available as a UN Document, dated December 14, 2013 as a download here: http://tbinternet.ohchr.org/_layouts/treatybodyexternal/Download.aspx?symbolno=CAT/C/USA/3-5).

Many cases have been dismissed in court not for lack of merit but rather because the US government has blocked suits at early stages by claiming the state secrets privilege.⁴⁹⁹ In other cases, courts have refused to weigh in, finding that the subject matter of the case touches on foreign policy or national security—issues normally within the purview of the executive branch.⁵⁰⁰ In still other cases government attorneys have successfully argued that claims are preempted under federal law or trigger various forms of immunity.⁵⁰¹ These cases have set precedents making it nearly impossible for detainees to effectively sue for torture and ill-treatment in US courts.⁵⁰² To ensure that victims of arbitrary arrest and torture have a genuine right to remedy in the United States, Congress should pass legislation calling for compensation, the executive branch should initiate its own compensation mechanism, and the Department of Justice should take a different stance on the state secrets privilege.

State Secrets Privilege

In the United States, the state secrets privilege allows the head of an executive department to refuse to produce evidence in a court case on the grounds that doing so would reveal secret information that would harm national security or foreign relations

⁴⁹⁹ *Mohamed v. Jeppesen Dataplan, Inc.*, 614 F.3d 1070 (9th Cir. Cal. 2010), p. 1092 (“[W]e do not reach our decision lightly or without close and skeptical scrutiny of the record and the government’s case for secrecy and dismissal... We ... acknowledge that this case presents a painful conflict between human rights and national security.”); *El-Masri v. United States*, 479 F.3d 296 (4th Cir. 2007), cert. denied 552 U.S. 947 (2007) (upholding lower court’s dismissal of suit on grounds that el-Masri, who alleged that he was kidnapped, illegally detained and abused by the CIA, would not be able to make his case except by using evidence barred by the state secrets privilege).

⁵⁰⁰ *Arar v. Ashcroft*, 585 F.3d 559 (cert. denied, June 14, 2010), pp. 565, 575, 578, 580-81 (upholding lower court’s dismissal of suit, on the basis that it would interfere with national security and foreign policy, by Canadian national who claimed he was sent by the United States to Syria, where he was tortured for one year until his release); see also cases brought by several former US detainees in Guantanamo, Iraq and Afghanistan blocked on the same theory which effectively would bar a suit brought by a CIA detainee on the same grounds: *Rasul v. Myers*, 563 F.3d 527, 532 n. 5 (D.C. Cir. 2009); *In re Iraq and Afghanistan Detainees Litigation*, 479 F. Supp. 2d 85 (D.D.C. 2007), pp. 103-07, affirmed by *Ali v. Rumsfeld*, 649 F.3d 762 (D.C. Cir. 2011), p. 765.

⁵⁰¹ See, for example, *Rasul v. Myers*, 563 U.S. 527 (2009) (affirming lower court’s dismissal of torture and related claims on immunity grounds); *Ali v. Rumsfeld*, 649 F.3d 762 (D.C. Cir. 2011) (dismissing claims on immunity grounds). See also *Saleh et al v. Titan Corporation*, Amicus Curiae Brief for the United States of America, May 2011, available at [http://www.ccrjustice.org/files/09-1313%20Titan%20US%20Br%20\(2\).pdf](http://www.ccrjustice.org/files/09-1313%20Titan%20US%20Br%20(2).pdf) (accessed May 4, 2011) (brief submitted by the Obama administration claiming that the court need not consider the case because federal preemption blocked consideration, and because there was no disagreement among lower courts requiring resolution by the Supreme Court).

⁵⁰² See ICTJ Accountability and Redress Report summarizing outcome of suits brought by former US detainees in CIA and military custody since September 11, 2001, pp. 12-17, 31-35. (See, for example, discussion of the Westfall Act under which courts have found US officials have immunity from suits for detainee abuse: “The Westfall Act protects federal employees from personal liability for torts committed within the scope of their employment; in these circumstances, it provides a defense of absolute immunity to federal officials ... Absolute immunity under the Westfall Act is available only to the extent the tort falls within the scope of official employment and does not fall within one of the law’s limited exceptions. Plaintiffs have argued unsuccessfully that torture or cruel, inhuman, or degrading treatment can never be within the scope of employment.”).

interests if disclosed.⁵⁰³ Courts can test these claims to a certain extent but in most cases have deferred to government assertions about the potential harms.⁵⁰⁴

The US government should reconsider its position on the state secrets privilege with regard to any new litigation brought forward in light of release of the Senate Summary, as much of the information that would be at issue is now publicly available.⁵⁰⁵

The Obama administration's own policy regarding state secrets requires that the privilege be invoked only "when genuine and significant harm to national defense or foreign relations is at stake and only to the extent necessary to safeguard those interests."⁵⁰⁶

The US has now conceded far more details about US authorized torture, and released far more details on the interrogation programs than ever before. It cannot credibly claim that litigating cases about such topics would endanger US national security. Prior to the release of the Senate Summary, US government officials made alarming claims about the dangers release of the report would pose, such as widespread anti-American protests.⁵⁰⁷ No evidence has been put forward that those claims ultimately came true.⁵⁰⁸ At minimum, the

⁵⁰³ *United States v. Reynolds*, US Supreme Court, No. 21, March 9, 1953, 345 U.S. 1 (1953).

⁵⁰⁴ *El-Masri v. United States*, 479 F.3d 296 (4th Cir. Va. 2007), pp. 305-306 ("Frequently, the explanation of the department head who has lodged the formal privilege claim, provided in an affidavit or personal declaration, is sufficient to carry the Executive's burden. In some situations, a court may conduct an in camera examination of the actual information sought to be protected, in order to ascertain that the criteria set forth in *Reynolds* are fulfilled. The degree to which such a reviewing court should probe depends in part on the importance of the assertedly privileged information to the position of the party seeking it. 'Where there is a strong showing of necessity, the claim of privilege should not be lightly accepted' On the other hand, 'even the most compelling necessity cannot overcome the claim of privilege if the court is ultimately satisfied that military secrets are at stake.' Indeed, in certain circumstances a court may conclude that an explanation by the Executive of why a question cannot be answered would itself create an unacceptable danger of injurious disclosure. In such a situation, a court is obliged to accept the executive branch's claim of privilege without further demand.").

⁵⁰⁵ See "Letter to Attorney General Loretta Lynch from American Civil Liberties Union Legal Director Steven R. Shapiro," *ACLU*, November 5, 2015, https://www.aclu.org/sites/default/files/field_document/aclu_letter_to_lynch_on_cia_torture_lawsuit.pdf (accessed November 16, 2015).

⁵⁰⁶ US Justice Department, "Memorandum on Policies and Procedures Governing Invocation of the State Secrets Privilege," September 23, 2009, <http://www.justice.gov/sites/default/files/opa/legacy/2009/09/23/state-secret-privileges.pdf> (accessed May 8, 2015), pp. 1-2. ("The Department will not defend an invocation of the privilege in order to: (i) conceal violations of law, inefficiency, or administrative error; (ii) prevent embarrassment to a person, organization or agency of the United States Government...; or (iv) prevent or delay the release of information the release of *which would not reasonably be expected to cause significant harm to national security.*" (emphasis in original)).

⁵⁰⁷ See "Dire warning over pending release of CIA torture report," *CBS News*, December 7, 2014, <http://www.cbsnews.com/news/mike-rogers-releasing-senates-cia-torture-report-a-terrible-idea/> (accessed June 8, 2015); see also Erin Kelly, "Officials fear torture report could spark violence," *USA Today*, December 9, 2014, <http://www.usatoday.com/story/news/politics/2014/12/08/cia-torture-report-senate-intelligence-committee/20087371/> (accessed June 8, 2015).

⁵⁰⁸ "Feinstein calls out Torture Report Threat Assessment," *C-SPAN*, February 12, 2015, <http://www.c-span.org/video/?c4527978/feinstein-calls-torture-report-threat-assessment> (accessed November 12, 2015); Joshua Keating,

courts should scrutinize government claims about the need for secrecy in the CIA torture context, and allow the cases to go forward with appropriate protective orders that would bar disclosure of sensitive material.

In the alternative, if the government is genuinely concerned about revealing state secrets it can offer to settle lawsuits rather than fight claims when it knows US officials have engaged in torture or other ill-treatment, or propose other types of compensation mechanisms that would assist victims with recovery.

Classifying Information about CIA Torture

Until December 2014, the US deemed all information relating to the CIA's detention and interrogation program as classified. This included even detainees' own "observations and experiences" about what happened to them while in CIA custody.⁵⁰⁹ The classification rule effectively barred former detainees who were still held at the Guantanamo Bay detention facility and their lawyers from making complaints about CIA torture to tribunals abroad, other third-parties, and to the outside world in general, because it would run afoul of US restrictions on classified information. About 25 detainees previously held by the CIA remain at Guantanamo.⁵¹⁰

"Why Hasn't the Torture Report Sparked Anti-American Protests?" *Slate*, December 11, 2014, http://www.slate.com/blogs/the_world_/2014/12/11/why_hasn_t_the_torture_report_sparked_anti_american_protests.html (accessed June 8, 2015).

⁵⁰⁹ *United States v. Mohammad, et al.*, Military Commissions Trial Judiciary, Guantanamo Bay, Order of 16 December 2013 Granting Defense Motion to Dismiss Because Amended Protective Order #1 Violates the Convention Against Torture, AE 20011 (December 16, 2013), available at [http://www.mc.mil/Portals/o/pdfs/KSM2/KSM%2011%20\(AE20011\).pdf](http://www.mc.mil/Portals/o/pdfs/KSM2/KSM%2011%20(AE20011).pdf) (accessed May 4, 2015), paras. 7-9. See also *United States v. Mohammad, et al.*, Military Commissions Trial Judiciary, Guantanamo Bay, Defense Motion to Dismiss Because Amended Protective Order #1 Violates the Convention Against Torture, AE 200 (August 12, 2013), available at [http://www.mc.mil/Portals/o/pdfs/KSM2/KSM%2011%20\(AE200\(MAHRBSWBA\)\).pdf](http://www.mc.mil/Portals/o/pdfs/KSM2/KSM%2011%20(AE200(MAHRBSWBA)).pdf) (accessed May 4, 2015) (Amended Protective Order 1 simply deleted the line which classified the "observations and experiences" of the defendants while in the CIA program but the bar against disclosure of information about the defendants' torture effectively remained because the US continued to control what information came to and left from the defendant at the facility and the entire CIA detention and interrogation program remained classified, even if the defendants' own observations and experiences about it did not).

⁵¹⁰ See "CIA Prisoner Database," *The Rendition Project*, undated, available as a download on this page: <http://www.therenditionproject.org.uk/prisoners/data.html> (accessed August 25, 2015). Of the former CIA prisoners listed in the database, 33 were listed as being "detained" as of August 25, 2015, though not all of them in Guantanamo and some have since been released. One of them for example, Ahmed Ghailani, is detained at a federal prison in the US. Two others, Ridha al Najjar and Lufti al-Gharsi, were held in Afghanistan but have since been released. See Kate Clark, "The 'Other Guantanamo' (13): What should Afghanistan do with America's foreign detainees?" *Afghanistan Analysts Network*, March 2,

The use of classification rules to block information about torture and ill-treatment from being made public violates article 13 of the Convention against Torture, which requires states to ensure that any individual subjected to torture under their jurisdiction “has the right to complain” and have their complaint “promptly and impartially examined.”⁵¹¹ In a legal document submitted in several cases before military commissions at Guantanamo since release of the Senate Summary, the US government took the position that the treatment and conditions of confinement of detainees while in CIA custody was no longer classified (though identities of individuals or other governments involved and locations of CIA detention centers remained classified).⁵¹²

However, as of this writing, court orders in the military commission cases that govern the way that classified information is handled in the military commissions, as well as cases brought on behalf of Guantanamo detainees challenging the lawfulness of their detention (known as “habeas corpus” cases), have not yet been updated. As a result, restrictions on the ability of lawyers representing detainees to discuss their clients’ treatment while in CIA custody remain in place. Lawyers representing one detainee of the CIA who is still in Guantanamo, Majid Khan, submitted their notes containing information about how Khan was treated in CIA custody for declassification review and were granted permission to share that information with the public.⁵¹³ Release of that information to the press generated stories about Khan being subjected to even more torture than is documented in the Senate Summary.⁵¹⁴ But a similar attempt on the part of Joseph Margulies, Abu Zubaydah’s lead defense lawyer, to release his client’s account of his CIA torture, was rejected in September 2015 for unknown reasons.⁵¹⁵

2015, <https://www.afghanistan-analysts.org/the-other-guantanamo-13-what-should-afghanistan-do-with-americas-foreign-detainees/> (accessed August 25, 2015). Samr al-Barq is listed as being held in “administrative detention” in Israel.

⁵¹¹ Convention against Torture, art. 13.

⁵¹² Marty Lederman, “‘Gag order’ on Military Commission defendants substantially lifted,” *JustSecurity*, <http://justsecurity.org/19615/gag-order-military-commission-defendants-substantially-lifted/>.

⁵¹³ David Rohde, “Exclusive: Detainee alleges CIA sexual abuse, torture beyond Senate findings,” *Reuters*, June 2, 2015, <http://www.reuters.com/article/2015/06/02/us-usa-torture-khan-idUSKBN0I1TW20150602> (accessed August 25, 2015).

⁵¹⁴ *Ibid.*

⁵¹⁵ David Rohde, “U.S. Government Blocks Release of New CIA Torture Details,” *Reuters*, September 10, 2015, <http://www.reuters.com/article/2015/09/11/us-usa-cia-torture-idUSKCN0RA2RM20150911> (accessed October 25, 2015); see

Legislation, Other Measures

In one of the cases dismissed on state secrets grounds, *Mohammed v. Jeppesen Dataplan, Inc.*, the Ninth Circuit Court of Appeals expressed discontent that the plaintiffs were deprived of an opportunity to prove their alleged mistreatment and obtain compensation.⁵¹⁶ The court also noted its dismissal eliminated judicial review, “an important check on alleged abuse by government officials and putative contractors.”⁵¹⁷ But the court also said the US government could still provide a remedy and pointed to a number of actions the US government had taken in the past in similar circumstances.⁵¹⁸

For example, during World War II, the US relocated and detained more than 110,000 citizens and non-citizens of Japanese ancestry in various locations in the US.⁵¹⁹ The Civil Liberties Act of 1988, signed into law by President Ronald Reagan, acknowledged the fundamental injustice of the “evacuation, relocation, and internment of United States citizens and permanent resident aliens of Japanese ancestry during World War II.”⁵²⁰ It also stated that government actions were motivated by “racial prejudice, wartime hysteria, and a failure of political leadership” rather than legitimate security concerns and gave each surviving detainee \$20,000.⁵²¹

The *Jeppesen* court pointed to settlements under this act as an example of ways the US had provided reparations for wrongful detentions of non-US citizens in the past. The Civil Liberties Act did not cover more than 2,000 Latin Americans of Japanese descent, including entire families, whom the US abducted from their countries and interned at camps in the US. They were not entitled to compensation because they were not US citizens or lawful permanent residents, a requirement under the statute. After the war the US returned many of them to Japan even though they were from Latin America, where some

also Joseph Margulies, “Open the Lid on US Torture,” *Al Jazeera America*, September 15, 2015, <http://america.aljazeera.com/opinions/2015/9/open-the-lid-on-us-torture.html> (accessed October 25, 2015); “Groups Urge End to Blocking Release of CIA Torture Details,” Human Rights Watch news release, September 18, 2015, <https://www.hrw.org/news/2015/09/18/groups-urge-end-blocking-release-cia-torture-details>.

⁵¹⁶ *Mohammed v. Jeppesen Dataplan, Inc.*, 614 F.3d 1070 (9th Cir. Cal. 2010) (cert. denied May 2011), p. 1091.

⁵¹⁷ *Ibid.*

⁵¹⁸ *Ibid.*

⁵¹⁹ *Internet Encyclopedia Britannica*, 2014, s.v. “Executive Order 9066,” <http://www.britannica.com/topic/Executive-Order-9066> (accessed November 16, 2015); see also Maisie Conrat and Richard Conrat, *Executive Order 9066: The Internment of 110,000 Japanese Americans* (Los Angeles: UCLA Asian American Studies Center Press, 1992).

⁵²⁰ Civil Liberties Act of 1988, 50 App. U.S.C. § 1989(a).

⁵²¹ Civil Liberties Act of 1988, 50 App. U.S.C. § 1989(a) and 1989b-4(a)(1).

of them ended up homeless and starving.⁵²² These Latin Americans brought a class action lawsuit based on the Civil Liberties Act that ended up settling, recorded in *Mochizuki v. United States*.⁵²³

In denying the plaintiff's claims, the *Jeppesen* court also indicated that Congress had the power to enact private bills.⁵²⁴ Generally such bills are meant to benefit solely the individuals named in them.⁵²⁵ While uncommon, private bills are meant to "address claims founded not on any statutory authority, but upon the claim that 'the equities and circumstances of a case create a moral obligation on the part of the Government to extend relief to an individual.'"⁵²⁶ The *Jeppesen* court also noted that Congress could also refer an individual claim to the Court of Federal Claims for a recommendation before enacting a private bill.⁵²⁷

No one in Congress or the executive has proposed legislation that would provide compensation to victims of CIA torture, nor has the executive offered any other way to resolve the issue.

In contrast to the US, several other countries have provided compensation to former detainees held by the CIA or the US military for which their own authorities also committed wrongdoing. They have done so even though the level of culpability may have been significantly lower than that of the US. Some of these settlements include:

- The United Kingdom has committed to mediation with those who have brought civil claims alleging UK involvement in torture and illegal renditions and wherever appropriate, to provide compensation ("[W]e are committed to mediation with

⁵²² *Mochizuki v. United States*, 43 Fed. Cl. 97 (Fed. Cl. 1999).

⁵²³ *Ibid.*

⁵²⁴ "When national security interests deny alleged victims of wrongful governmental action meaningful access to a judicial forum, private bills may be an appropriate alternative remedy." *Mohammed v. Jeppesen*, p. 1092.

⁵²⁵ "Private laws differ from public laws in that they lack general applicability and do not apply to all persons. Instead they are generally 'designed to provide legal relief to specified persons or entities adversely affected by laws of general applicability.' Private laws apply only to the person named in the law and grant a benefit from the government to that person, not otherwise authorized by law." Matthew Mantel, "Private Bills and Private Laws," *Law Library Journal* 99 (2007): 88.

⁵²⁶ *Office of Pers. Management v. Richmond*, 496 U.S. 414, 431 (U.S. 1990), citing Subcommittee on Administrative Law and Governmental Relations of the House Committee on the Judiciary, Supplemental Rules of Procedure for Private Claims Bills, 101st Cong., 1st Sess., p. 2 (Comm. Print 1989).

⁵²⁷ *Mohammed v. Jeppesen*, p. 1092, citing 28 U.S.C. §§ 1492, 2509(c).

those who have brought civil claims about their detention in Guantanamo. And wherever appropriate, we will offer compensation.”).⁵²⁸

- The UK has already settled claims brought by 16 former Guantanamo detainees.⁵²⁹
- The UK in December 2012 settled a case with Sami al-Saadi who was unlawfully rendered by the CIA, with the cooperation of UK intelligence services, to Libya.⁵³⁰ A second civil case against the UK government by a Libyan rendition victim, Abdul Hakim Belhadj, is ongoing.⁵³¹
- In 2008 the Swedish government formally apologized for its role in the CIA’s unlawful rendition of Ahmed Agiza and Muhammed Alzery to Egypt and compensated each the equivalent of \$500,000.⁵³²
- In 2007, the Canadian government apologized for its role in the unlawful rendition of Maher Arar to Syria by the CIA in 2002 and paid him a settlement of C\$9.7 million.⁵³³ (Arar brought suit in the US earlier, but his case was dismissed on grounds that the judicial branch should not weigh in on US rendition policy— according to the court, a foreign relations issue within the purview of the executive branch).
- In 2010, Australia paid out an undisclosed settlement to Mamdouh Habib, a former Guantanamo detainee.⁵³⁴ Habib is an Australian national who was arrested in Pakistan shortly after the September 11 attacks, secretly taken to Egypt, where he

⁵²⁸ Speech from David Cameron, Prime Minister to the House of Commons, “Statement on detainees,” July 6, 2010, <https://www.gov.uk/government/speeches/statement-on-detainees> (accessed July 1, 2015).

⁵²⁹ “U.K. to pay millions to ex-Gitmo terror suspects,” *NBC News*, November 16, 2010, http://www.nbcnews.com/id/40210747/ns/world_news-europe/t/uk-pay-millions-ex-gitmo-terror-suspects/%20-%20.VWOT2U9Viko#.VYGBMThMuUk (accessed July 1, 2015).

⁵³⁰ Richard Norton-Taylor, “Government pays Libyan dissident’s family £2.2m over M16-aided rendition,” *The Guardian*, December 13, 2012, <http://www.theguardian.com/uk/2012/dec/13/libyan-dissident-mi6-aided-rendition> (accessed August 25, 2015).

⁵³¹ Owen Bowcott, “Abdel Hakim Belhaj wins right to sue UK government over his kidnap,” *The Guardian*, October 30, 2014, <http://www.theguardian.com/world/2014/oct/30/abdel-hakim-belhaj-court-kidnap-mi6-cia-torture> (accessed August 25, 2015).

⁵³² Louise Nordstrom, “Egyptian deported by CIA gets residency in Sweden,” *World Post*, July 4, 2012, <http://www.huffingtonpost.com/huff-wires/20120704/eu-sweden-cia-flights/> (accessed July 1, 2015); “Sweden to compensate exonerated terror suspect,” *New York Times*, July 3, 2008, http://www.nytimes.com/2008/07/03/world/europe/03iht-sweden.5.14218093.html?_r=0 (accessed November 16, 2016).

⁵³³ Ian Austen, “Canada to Pay \$9.75 Million to Man Tortured in Syria,” *New York Times*, January 27, 2007, http://www.nytimes.com/2007/01/27/world/americas/27canada.html?_r=0 (accessed November 16, 2015).

⁵³⁴ Natalie O’Brien, “Australian official saw Egyptians torture Habib,” *Sydney Morning Herald*, February 13, 2011, <http://www.smh.com.au/national/australian-official-saw-egyptians-torture-habib-20110212-1ardt.html> (accessed April 29, 2015).

was tortured for seven months, and then transferred to Guantanamo Bay, where he was held until January 2005.⁵³⁵

In addition to these settlements, the European Court of Human Rights has ruled against Poland for its role in the detention and torture of two former detainees in CIA custody, Abu Zubaydah⁵³⁶ and Abd al-Nashiri.⁵³⁷ It also ruled against Macedonia for its role in the abduction and torture of Khaled el-Masri.⁵³⁸ A US federal court had dismissed el-Masri's case on state secrets grounds in 2006 and his appeals were all denied.⁵³⁹ The European Court ordered Poland and Macedonia to pay €250,000 and €60,000 respectively. Poland has paid out its settlement to Abu Zubaydah and al-Nashiri.⁵⁴⁰ Macedonia was due to pay within three months of the judgment on December 12, 2012.⁵⁴¹

Guarantee of Non-Repetition, Satisfaction, and the Right to Truth

The right to redress encompasses the concepts of “effective remedy” and “reparation,” which not only include restitution, compensation, and rehabilitation but also “guarantees of non-repetition” and “satisfaction.”⁵⁴²

With regard to non-repetition, the Committee against Torture has interpreted the Convention against Torture to provide that states are obligated to combat impunity for

⁵³⁵ Ibid.

⁵³⁶ European Court of Human Rights, *Case of Husayn (Abu Zubaydah) v. Poland*, (no. 7511/13), Judgment of 24 July 2014, available at <http://hudoc.echr.coe.int/sites/eng/pages/search.aspx?i=001-146047> (accessed November 16, 2015).

⁵³⁷ European Court of Human Rights, *Case of Al-Nashiri v. Poland*, (no. 28761/11), Judgment of 24 July 2014, available at <http://hudoc.echr.coe.int/sites/eng/pages/search.aspx?i=001-146044> (accessed November 16, 2015).

⁵³⁸ European Court of Human Rights, *El-Masri v. The Former Yugoslav Republic of Macedonia*, (no. 39630/09), Judgment of December 13, 2012, available at <http://hudoc.echr.coe.int/sites/eng/pages/search.aspx?i=001-115621>.

⁵³⁹ *El-Masri v. United States*, 479 F.3d 296.

⁵⁴⁰ “Poland pays \$250,000 to victims of CIA rendition and torture,” *The Guardian*, May 15, 2015, <http://www.theguardian.com/world/2015/may/15/poland-pays-250000-alleged-victims-cia-rendition-torture> (accessed August 25, 2015).

⁵⁴¹ European Court of Human Rights, *El-Masri v. The Former Yugoslav Republic of Macedonia*, para. 273(12).

⁵⁴² UN Committee against Torture, General Comment No. 3 (Implementation of Article 14 by States Parties), http://www1.umn.edu/humanrts/cat/general_comments/cat_gen_com3.html (accessed July 1, 2015), para. 2; UN General Assembly Resolution 60/147, “Basic Principles and Guidelines on the Right to a Remedy and Reparation for Victims of Gross Violations of International Human Rights Law and Serious Violations of International Humanitarian Law,” December 2005, <http://www.ohchr.org/EN/ProfessionalInterest/Pages/RemedyAndReparation.aspx> (accessed April 28, 2015), para. 18 (“In accordance with domestic law and international law, and taking account of individual circumstances, victims of gross violations of international human rights law and serious violations of international humanitarian law should, as appropriate and proportional to the gravity of the violation and the circumstances of each case, be provided with full and effective reparation, as laid out in principles 19 to 23, which include the following forms: restitution, compensation, rehabilitation, satisfaction and guarantees of non-repetition.”).

violations, including by taking measures such as “establishing effective clear instructions to public officials on the provisions of the Convention, especially the absolute prohibition of torture”; “civilian oversight of military and security forces”; “establishing systems for regular and independent monitoring of all places of detention”; providing training for security forces and health and legal professionals on human rights law, including specific training on the Istanbul Protocol (on documentation of torture); and “reviewing and reforming laws contributing to or allowing torture and ill-treatment.”⁵⁴³ A UN General Assembly resolution sets out more general measures for victims of serious human rights and international humanitarian law violations.⁵⁴⁴

Though then-President George W. Bush disclosed the CIA rendition, detention, and interrogation program in 2006 and moved a number of prisoners from CIA custody to Guantanamo, the program did not officially end until President Barack Obama issued executive order 13491 on his second day in office. This order barred the CIA from operating detention facilities and from holding detainees on all but a temporary, transitory basis; required all US personnel to abide by the Army Field Manual for Intelligence Interrogations; and required that the International Committee of the Red Cross have prompt access to all laws-of-war detainees.⁵⁴⁵

These are important measures. But Obama’s executive order is not adequate to ensure non-repetition in the future—particularly when inaction on investigations and prosecutions sends the message to those responsible for torture that the law will not be enforced. Upon the release of the Senate Summary, CIA Director John Brennan made significant admissions about mistakes the CIA had made in running, operating, reporting on, and promoting the program. However, he also said whether the techniques had some value was “unknowable.” And when asked what was to stop future policy makers from using them again, he said the CIA was not currently contemplating reinstating the detention program or using “enhanced interrogation techniques” but he

⁵⁴³ UN Committee against Torture, General Comment No. 3, http://www2.ohchr.org/english/bodies/cat/docs/GC/CAT-C-GC-3_en.pdf (accessed November 16, 2015), para. 18.

⁵⁴⁴ See Basic Principles, para. 23.

⁵⁴⁵ “Executive Order 13491 – Ensuring Lawful Interrogations,” The White House, January 22, 2009, https://www.whitehouse.gov/the_press_office/EnsuringLawfulInterrogations (accessed May 2, 2015).

deferred to “policymakers in future times” regarding whether they might need to be used again in a similar type of “crisis.”⁵⁴⁶

There remains a very real danger that US officials will again view torture as a viable policy option. Obama’s executive order, like all executive orders, can be revoked by future presidents. Several 2016 presidential candidates have defended the “enhanced interrogation techniques” and said or implied that they would use them again.⁵⁴⁷ US presidential candidate Jeb Bush, when asked whether he would contemplate using “enhanced interrogation techniques” if he were elected, did not rule out the possibility and also said that waterboarding was not torture.⁵⁴⁸

The best way to ensure that torture and other ill-treatment will not be used in the future is by prosecuting past unlawful acts. Strengthening existing legislation against torture would also establish clearly that the US government does not intend to engage in such practices again.

On June 16, 2015, the US Senate passed an amendment proposed by senators John McCain and Dianne Feinstein to a defense spending bill (the National Defense Authorization Act for Fiscal Year 2016) that if it becomes law, could codify much of what is in Obama’s executive order 13491.⁵⁴⁹ The amendment passed in the Senate by a vote of 78-21.⁵⁵⁰ The

⁵⁴⁶ “TRANSCRIPT: CIA Director John Brennan Addresses Senate’s Report on CIA Interrogation Program,” *ABC News*, December 11, 2014, <http://abcnews.go.com/International/transcript-cia-director-john-brennan-senates-report-cia/story?id=27539690&singlePage=true> (accessed July 1, 2015).

⁵⁴⁷ Kailli Joy Gray, “Donald Trump And Fox & Friends: It’s Cool, Sydney Hostage-Takers, CIA Was ‘Just Following Orders,’” *Wonkette*, December 15, 2014, <http://wonkette.com/569220/donald-trump-and-fox-friends-its-cool-sydney-hostage-takers-cia-was-just-following-orders#iweGwD3WVS1CKQic.99> (accessed October 25, 2015); Heather Digby Parton, “Ben Carson’s sick torture rationale: Is this 2016’s most deluded contender?” *Salon*, February 20, 2015, http://www.salon.com/2015/02/20/ben_carsons_sick_torture_rationale_is_this_2016s_most_deluded_contender/ (accessed October 25, 2015); Michael Isikoff, “Carly Fiorina Defends Bush-era Torture and Spying, Calls for More Transparency,” *Yahoo Politics*, September 28, 2015, https://www.yahoo.com/politics/carly-fiorina-defends-bush-era-torture-and-spying-130015256041.html?soc_src=social-sh&soc_trk=tw (accessed October 25, 2015); James Q. Lynch, “Rick Perry won’t rule out torture to protect Americans from domestic terrorism,” *The Gazette*, May 20, 2015, <http://thegazette.com/subject/news/government/rick-perry-wont-rule-out-torture-to-protect-americans-from-domestic-terrorism-20150520> (accessed July 1, 2015).

⁵⁴⁸ Trip Gabriel, “Jeb Bush Says He Won’t Rule Out Waterboarding in Interrogations,” *New York Times*, August 14, 2015, <http://www.nytimes.com/politics/first-draft/2015/08/14/jeb-bush-says-he-wont-rule-out-waterboarding-in-interrogations/> (accessed August 25, 2015).

⁵⁴⁹ “US: Support Anti-Torture Legislation,” Human Rights Watch news release, June 16, 2015, <http://www.hrw.org/news/2015/06/16/us-support-anti-torture-legislation>.

⁵⁵⁰ Julian Hatter, “Senate votes to ban use of torture,” *The Hill*, June 16, 2015, <http://thehill.com/policy/national-security/245117-senate-votes-to-permanently-ban-use-of-torture> (accessed November 12, 2015).

entire bill was then vetoed by Obama over other issues, but a similar provision remained in the compromised version bill which, as of this writing, was expected to be signed into law by the President.⁵⁵¹ It provides that any individual detained by the US in an armed conflict can only be interrogated in ways outlined by the US Army Field Manual on Intelligence Interrogations. It also requires review and updating of the manual within three years to ensure that it reflects current best practice and complies with all US legal obligations and requires that the International Committee of the Red Cross get “notification of, and prompt” access to, all prisoners held by the US in any armed conflict.⁵⁵² It is already clear under US law that torture and other ill-treatment is illegal but this requirement would help to more specifically restrain the physical action certain US interrogators could take.⁵⁵³ However, it is also impossible to know for sure how future administrations will interpret its obligations under the provisions. Additionally, an exemption for the FBI, the Department of Homeland Security, and other federal “law enforcement entities” was added to the compromised version of the bill.

⁵⁵¹ Rebecca Shabad, “White House expects President Obama to sign defense bill,” *CBS*, November 10, 2015, [http://www.cbsnews.com/news/white-house-expects-president-obama-to-sign-defense-bill/?utm_source=feedburner&utm_medium=feed&utm_campaign=Feed%3A+cbsnews%2Ffeed+\(CBSNews.com\)](http://www.cbsnews.com/news/white-house-expects-president-obama-to-sign-defense-bill/?utm_source=feedburner&utm_medium=feed&utm_campaign=Feed%3A+cbsnews%2Ffeed+(CBSNews.com)) (accessed November 12, 2015).

⁵⁵²“US: Support Anti-Torture Legislation,” Human Rights Watch news release.

⁵⁵³ Though the Interrogation Manual bars many forms of abusive treatment, its Appendix M still allows some abusive forms of sleep and sensory deprivation. For example, it permits limiting detainees to only four hours of sleep every 24 hours, permitting 40 hours of sleep deprivation at a time, potentially over an extended period. US officials have said that Appendix M would not be applied in a way that allows for such abuse but the text as written would still permit such practices. During the next Defense Department review process, the US should remove the provisions in Appendix M that allow for abuse through isolation or sleep and sensory deprivation that can amount to torture or ill-treatment.

IV. International Accountability Mechanisms

The US government's failure to conduct adequate criminal investigations into allegations of torture and other serious abuses committed by US nationals in the context of the CIA's rendition, detention, and interrogation program has opened the door to investigations and prosecutions by national judicial authorities outside the United States.⁵⁵⁴

Investigations to date have targeted both US officials and those from other countries since a number of European countries provided support to the CIA program, in particular by allowing US officials to establish secret prisons known as "black sites" on their territory or to use their airports and airspace to conduct rendition flights. Several investigations have also focused on allegations of torture and other serious abuses committed outside of the context of the CIA program, principally around torture and ill-treatment of detainees held at Guantanamo Bay; in Iraq (especially at Abu Ghraib prison); and in Afghanistan. In addition, the International Criminal Court (ICC) has opened a preliminary examination into the situation in Afghanistan and is assessing whether to open a formal investigation, including into allegations of detainee abuse by members of the US armed forces.

Jurisdiction over criminal offenses normally depends on a link between the prosecuting state and the crime. Most often this link is territorial, meaning that the crime occurred in the state that is prosecuting the crime. In other instances, the link is that the alleged perpetrator or the victim is a national of that country.⁵⁵⁵ However, judicial authorities of third countries may also investigate and prosecute the most serious international crimes—including war crimes, torture, crimes against humanity, and genocide—even where the crimes took place elsewhere and neither the accused nor the victims are nationals of that state. Such cases are pursued under the international law principle of "universal jurisdiction," which embodies the idea that certain crimes are so egregious that every state has an interest and corresponding duty in bringing perpetrators to justice.⁵⁵⁶

⁵⁵⁴ See section of this report titled "Justice Department Inquiry into CIA Torture" in the "Background" section above.

⁵⁵⁵ These are known as "active personality" or "passive personality" jurisdiction.

⁵⁵⁶ For more information on universal jurisdiction, see Human Rights Watch, *The Pinochet Precedent: How Victims Can Pursue Human Rights Criminals Abroad*, November 1, 1998, <http://www.hrw.org/en/reports/1998/11/01/pinochet-precedent>; *Universal Jurisdiction in Europe: The State of the Art*, vol. 18, no. 5(D), June 2006, <http://www.hrw.org/sites/default/files/reports/ij0606web.pdf>; *The Long Arm of Justice: Lessons from Specialized War Crimes Units in France, Germany, and the Netherlands*, September 2014, http://www.hrw.org/sites/default/files/reports/110914_ForUpload.pdf.

Universal jurisdiction provides an important safety net for ensuring accountability when serious crimes cannot or will not be effectively prosecuted in the state where the crimes were committed or before an international criminal tribunal. For certain crimes, including war crimes, and torture, international treaties and customary international law place an affirmative duty on states to exercise universal jurisdiction and prosecute suspects who come onto their territory, unless the state decides to extradite them to face trial elsewhere.⁵⁵⁷

The principle of universal jurisdiction has existed for centuries. However, its application to human rights abuses and war crimes only began to gain real momentum in the past two decades, with the arrest of former Chilean President Augusto Pinochet in the United Kingdom in 1998 on charges of torture committed in Chile.⁵⁵⁸ Since then, more and more governments, particularly in Europe, have been willing to use domestic universal jurisdiction laws to ensure that those responsible for torture, war crimes, and other international crimes do not escape justice.⁵⁵⁹ At the same time, most cases brought to trial under universal jurisdiction

⁵⁵⁷ The Convention against Torture—ratified by the United States and 157 other countries—provides that “[t]he State Party in the territory under whose jurisdiction a person alleged to have committed [torture] is found shall ... if it does not extradite him, submit the case to its competent authorities for the purpose of prosecution.” Each of the four Geneva Conventions of 1949 relating to war crimes, which the United States and virtually every country have ratified, has a similar provision. The International Convention for the Protection of All Persons from Enforced Disappearance contains a similar provision. See Convention against Torture; Geneva Convention for the Amelioration of the Condition of the Wounded and Sick in Armed Forces in the Field, adopted August 12, 1949, 75 UNTS 31, entered into force October 21, 1950, art. 49, <https://www.icrc.org/applic/ihl/ihl.nsf/Treaty.xsp?documentId=4825657BoC7E6BFoC12563CD002D6BoB&action=openDocument>; Geneva Convention for the Amelioration of the Condition of Wounded, Sick and Shipwrecked Members of Armed Forces at Sea, adopted August 12, 1949, 75 UNTS 85, entered into force October 21, 1950, art. 50, <https://www.icrc.org/applic/ihl/ihl.nsf/Treaty.xsp?documentId=2F5AA9Bo7AB61934C12563CD002D6B25&action=openDocument>; Geneva Convention relative to the Treatment of Prisoners of War, adopted August 12, 1949, 75 UNTS 135, entered into force October 21, 1950, art. 129, <https://www.icrc.org/applic/ihl/ihl.nsf/Treaty.xsp?documentId=77CB9983BE01D004C12563CD002D6B3E&action=openDocument>; Geneva Convention relative to the Protection of Civilian Persons in Time of War, adopted August 12, 1949, 75 UNTS 287, entered into force October 21, 1950, art. 146, <https://www.icrc.org/applic/ihl/ihl.nsf/Treaty.xsp?documentId=AE2D398352C5Bo28C12563CD002D6B5C&action=openDocument>; International Convention for the Protection of All Persons from Enforced Disappearance, adopted December 20, 2006, G.A. Res. 61/177, U.N. Doc. A/61/448, entered into force December 23, 2010, art. 9, <http://www.ohchr.org/EN/HRBodies/CED/Pages/ConventionCED.aspx>. All UN member states have ratified treaties with obligations to exercise jurisdiction over foreigners suspected of committing certain crimes abroad against other foreigners. Amnesty International, “International Law Commission: The obligation to extradite or prosecute (*aut dedere aut judicare*),” February 3, 2009, <http://www.amnesty.org/en/library/info/IOR40/001/2009/en> (accessed March 23, 2015), pp. 74-98. See also International Law Commission, “Survey of multilateral conventions which may be of relevance for the work of the International Law Commission on the topic ‘The obligation to extradite or prosecute (*aut dedere aut judicare*)’, Study by the Secretariat,” U.N. Doc. A/CN.4/630, June 18, 2010, http://legal.un.org/ilc/documentation/english/a_cn4_630.pdf (accessed March 24, 2015).

⁵⁵⁸ See Human Rights Watch, *The Pinochet Precedent*.

⁵⁵⁹ According to a 2012 survey conducted by Amnesty International, 163 states have some form of universal jurisdiction legislation in place, with courts in at least 85 countries able to exercise universal jurisdiction over the crime of torture and at least 136 countries able to do so for war crimes. Amnesty International, “Universal Jurisdiction: A Preliminary Survey of Legislation around the World – 2012 Update,” October 9, 2012, <https://www.amnesty.org/download/Documents/24000/ior530192012en.pdf> (accessed June 3, 2015), pp. 2, 12-13.

have involved low- and mid-level suspects from less powerful countries.⁵⁶⁰ In 2008, US prosecutors notably secured a first conviction under its Torture Act, which allows cases based on universal jurisdiction to prosecute torture committed abroad, against the son of former Liberian dictator Charles Taylor, Charles “Chuckie” Taylor, Jr.⁵⁶¹ The trial of former Chadian dictator Hissène Habré in Senegal, which began on July 20, also marks the first time in history that a former head of state is prosecuted by the domestic courts of another country and the first universal jurisdiction case to proceed to trial in Africa.⁵⁶²

Human Rights Watch has compiled a review, set forth below, of criminal investigations initiated abroad into torture and other serious abuses committed as part of the CIA program or by US armed forces since the 9/11 attacks.⁵⁶³ Many of these investigations do not make a distinction between US military and CIA abuses, so we have included investigations regardless of whether the military or the CIA was the dominant focus. Nearly all of the cases have been initiated by victims and civil society groups, and all have occurred in Europe. Many European civil law jurisdictions, unlike most common law countries like the US, allow victims and in some cases nongovernmental organizations to file criminal complaints directly with the courts, thereby triggering the opening of a judicial investigation.⁵⁶⁴ Many criminal complaints filed by private parties have not resulted in actual investigations. Italy is the only country to have brought a case to trial, which eventually resulted in the final *in absentia* convictions of CIA officers and a US air force colonel, as well as several Italian officers.⁵⁶⁵ The

⁵⁶⁰ Over the past two decades, universal jurisdiction cases have been brought before the courts of Argentina, Austria, Belgium, Canada, Denmark, Finland, France, Germany, the Netherlands, Norway, Senegal, Spain, Sweden, Switzerland, the United Kingdom, and the United States. Human Rights Watch, *Universal Jurisdiction in Europe; The Long Arm of Justice*, annexes. See also Redress and International Federation for Human Rights (FIDH), “Extraterritorial Jurisdiction in the European Union: A Study of the Laws and Practice in the 27 Member States of the European Union,” December 2010, http://www.redress.org/downloads/publications/Extraterritorial_Jurisdiction_In_the_27_Member_States_of_the_European_Union.pdf (accessed March 24, 2015).

⁵⁶¹ Chuckie Taylor was actually a US citizen who was initially arrested while attempting to enter the US for a passport violation. See “First Verdict for Overseas Torture: Decision in Trial of Ex-Liberian President’s Son Significant for Justice,” Human Rights Watch news release, October 30, 2008, <http://www.hrw.org/news/2008/10/30/us-first-verdict-overseas-torture>.

⁵⁶² “Hissène Habré Trial to Begin July 20: Former Chad Dictator Charged with Crimes against Humanity,” Human Rights Watch news release, May 13, 2015, <http://www.hrw.org/news/2015/05/13/senegal-hissene-habre-trial-begin-july-20>.

⁵⁶³ This list is restricted to criminal cases and does not discuss other civil cases and inquiries that are underway or have been completed.

⁵⁶⁴ For more information, see Human Rights Watch, *The Legal Framework for Universal Jurisdiction in France*, September 2014, http://www.hrw.org/sites/default/files/related_material/110914France_3.pdf, pp. 4-6. The European Center for Constitutional and Human Rights (ECCHR), the Center for Constitutional Rights (CCR), the International Federation for Human Rights (FIDH), and the Open Society Justice Initiative (OSJI) have been the most active nongovernmental organizations (NGOs) in terms of filing criminal complaints against US officials for alleged torture and other serious abuses.

⁵⁶⁵ Malaysia also held criminal proceedings before a commission, but the commission is not part of the national judicial system, so its judgment was “merely declaratory in nature.” *Prosecutor v. George W. Bush & 7 Others*, Kuala Lumpur War

trial brought to light important information that was tempered by being *in absentia*, which raises serious fair trial concerns.⁵⁶⁶

Nearly all of the other criminal investigations initiated against US nationals to date have been closed. However, a criminal investigation in France is progressing slowly. And Germany's federal prosecutor's office is considering whether to open an investigation into senior members of the Bush administration following the filing of a new complaint by the European Center for Constitutional and Human Rights (ECCHR) in December 2014, shortly after the release of the Senate Summary.

Mounting evidence of involvement by governments in Europe in the CIA program—underscored by the Senate Summary—and growing pressure from civil society groups, and court judgements, led several countries to open criminal investigations into complicity by their nationals. This includes Poland where the investigations have languished, and in Lithuania where investigations were opened briefly, closed for a number of years, and then reopened when the Senate Summary was made public. UK authorities have initiated four separate investigations, two of which remain open.

Overall, these cases are an important reminder to the US government that legal avenues for accountability are not just available in the United States, and that US officials involved in the CIA program are not free and clear just because the US government has thus far been unwilling to bring cases.

However, as discussed below, European efforts at investigating the CIA program have faced political pressure from the US and actions by US authorities to block investigations. European governments will need to demonstrate greater commitment and persistence if these cases are to proceed to indictments and prosecutions.

Crimes Commission, Case No. 2-CTH-2011, Judgment, May 11, 2012, <http://criminalisewar.org/tribunal/Judgement%20KLWCT%20May%202012.pdf> (accessed April 30, 2015), para. 23.4. "Bush and Associates Found Guilty of Torture," Kuala Lumpur Foundation to Criminalise War press release, May 11, 2012, <http://criminalisewar.org/2012/press-release-bush-and-associates-found-guilty-of-torture> (accessed April 30, 2015).

⁵⁶⁶ Trials *in absentia* compromise the ability of an accused to exercise their rights to a legal defense under article 14 of the International Covenant on Civil and Political Rights. Those rights compromised include the right to be present during the trial, the right to defend oneself through counsel of choice, and the right to examine witnesses.

European governments should also ensure that accountability extends to those non-US nationals who bear responsibility for torture and other serious abuses committed in connection with the CIA rendition, detention, and interrogation program. A study by the Open Society Justice Initiative (OSJI) in 2013 found that 54 foreign countries provided support of some form to the CIA program, with 21 of those countries being within Europe.⁵⁶⁷ The active participation of European countries in the CIA program has been widely confirmed.⁵⁶⁸ Each of these countries should ensure that thorough and impartial criminal investigations are carried out to establish the responsibility of not only US officials over whom their courts may have jurisdiction, but also their own nationals. Toward this end, European and other countries that may have been complicit or participated in the CIA program should request a copy of the full Senate report with minimal redactions.⁵⁶⁹ They should also inform the US government that they have no objections to the report publicly naming their country.

⁵⁶⁷ Open Society Justice Initiative (OSJI), “Globalizing Torture: CIA Secret Detention and Extraordinary Rendition,” February 2013, <http://www.opensocietyfoundations.org/sites/default/files/globalizing-torture-20120205.pdf> (accessed June 4, 2015).

⁵⁶⁸ See UN Human Rights Council, “Joint Study on Global Practices in Relation to Secret Detention in the Context of Countering Terrorism of the Special Rapporteur on the Promotion and Protection of Human Rights and Fundamental Freedoms while Countering Terrorism, Martin Scheinin; the Special Rapporteur on Torture and other Cruel, Inhuman or Degrading Treatment or Punishment, Manfred Nowak; the Working Group on Arbitrary Detention Represented by its Vice-Chair, Shaheen Sardar Ali; and the Working Group on Enforced or Involuntary Disappearances represented by its Chair, Jeremy Sarkin” (“UN Joint Study on Secret Detention”), U.N. Doc. A/HRC/13/42, February 19, 2010, <http://www2.ohchr.org/english/bodies/hrcouncil/docs/13session/A-HRC-13-42.pdf> (accessed June 4, 2015), para. 159; UN Human Rights Council, Report on the promotion and protection of human rights and fundamental freedoms while countering terrorism, U.N. Doc. A/HRC/10/3, February 4, 2009, <http://www2.ohchr.org/english/bodies/hrcouncil/docs/10session/A.HRC.10.3.pdf> (accessed June 16, 2015), para. 52; Parliamentary Assembly of the Council of Europe, “Alleged secret detentions and unlawful inter-state transfers of detainees involving Council of Europe member states,” June 12, 2006, <http://assembly.coe.int/nw/xml/XRef/X2H-Xref-ViewPDF.asp?FileID=11527&lang=en> (accessed June 15, 2015); Parliamentary Assembly of the Council of Europe, “Secret detentions and illegal transfers of detainees involving Council of Europe member states: second report,” June 11, 2007, <http://assembly.coe.int/nw/xml/XRef/X2H-Xref-ViewPDF.asp?FileID=11555&lang=en> (accessed June 15, 2015); European Parliament Resolution of 11 February 2015 on the US Senate report on the use of torture by the CIA (2014/2997(RSP)), <http://www.europarl.europa.eu/sides/getDoc.do?pubRef=-//EP//TEXT+TA+P8-TA-2015-0031+0+DOC+XML+Vo//EN> (accessed June 17, 2015); European Parliament Resolution of 10 October 2013 on alleged transportation and illegal detention of prisoners in European countries by the CIA (2013/2702(RSP)), <http://www.europarl.europa.eu/sides/getDoc.do?pubRef=-//EP//TEXT+TA+P7-TA-2013-0418+0+DOC+XML+Vo//EN> (accessed June 4, 2015); European Parliament Resolution of 11 September 2012 on alleged transportation and illegal detention of prisoners in European countries: follow-up of the European Parliament TDIP Committee report (2012/2033(INI)), <http://www.europarl.europa.eu/sides/getDoc.do?type=TA&reference=P7-TA-2012-0309&language=EN&ring=A7-2012-0266> (accessed June 4, 2015); Human Rights Watch, *Delivered into Enemy Hands*; OSJI, “Globalizing Torture: CIA Secret Detention and Extraordinary Rendition”; Amnesty International, “Partners in Crime: Europe’s Role in US Renditions,” June 14, 2016, http://www.amnesty.eu/static/documents/2006/Partners_in_crime_14062006.pdf (accessed June 15, 2006); International Committee of the Red Cross (ICRC), “ICRC Report on the Treatment of Fourteen ‘High Value Detainees’ in CIA Custody,” February 2007, <http://assets.nybooks.com/media/doc/2010/04/22/icrc-report.pdf> (accessed June 17, 2015).

⁵⁶⁹ This is consistent with the European Parliament Resolution of 11 February 2015 on the US Senate report on the use of torture by the CIA.

A number of countries may be in a position to exercise jurisdiction over US and foreign officials for their role in serious abuses committed as part of the CIA program and related mistreatment of persons in detention. Victims and witnesses, and other relevant evidence, may be located within their jurisdiction, which may oblige national authorities to investigate and prosecute the offenses.

Germany may provide a useful model as to how prosecutorial authorities can be proactive under the principles of universal jurisdiction. German prosecutors now have the ability to conduct broad preliminary investigations known as “structural investigations.” These are aimed at cataloguing crimes (as opposed to focusing on specific individuals), gathering details about them, and identifying potential victims and witnesses and other evidence to facilitate future criminal proceedings before national courts or elsewhere.⁵⁷⁰ This could help lay the groundwork for investigation of specific individuals should they enter Germany.

In addition, possible suspects from the US or elsewhere may be present in or travel to Europe or other countries that may have jurisdiction over them, thereby providing an opportunity for their arrest and, provided there is sufficient evidence, prosecution. National immigration, police, and judicial authorities should prepare for this eventuality, be vigilant to the identity of persons traveling to their countries, and work together to ensure that police and prosecutors are given an adequate opportunity to consider investigation and prosecution where suspects arrive on their territory. Human Rights Watch and four other nongovernmental organizations (NGOs) have sought a meeting of war crimes prosecutors from EU countries to discuss the Senate Summary and efforts to ensure accountability for CIA-related abuses.⁵⁷¹

The ICC may also prove to be a path toward some accountability for US abuses committed in Afghanistan. The ICC is conducting a preliminary examination into alleged international crimes by all parties in Afghanistan. Should it decide to open a formal investigation in Afghanistan, it will need to consider including US abuses as part of its investigation.

⁵⁷⁰ For more information, see Human Rights Watch, *The Long Arm of Justice*, p. 60.

⁵⁷¹ Letter from Human Rights Watch, Redress, FIDH, ECCHR, and TRIAL to members of the EU Genocide Network, “Discussing Ongoing and Potential Investigations and Prosecutions Following the Release of the US Senate Intelligence Committee Report Summary,” April 20, 2015, <http://www.hrw.org/news/2015/04/20/letter-members-eu-genocide-network-discussing-ongoing-and-potential-investigations-a>.

Given the confidential nature of judicial investigations, particularly when cases are at an early stage, it is possible that judicial authorities in other countries have investigated or are pursuing similar investigations, but the information is not available publicly. The information provided below is therefore not necessarily an exhaustive list of all criminal cases that have occurred or are pending in foreign jurisdictions.

Investigations and Prosecutions of US Officials

Italy

In November 2009, a court in Milan convicted 23 Americans and two Italian military intelligence officers for aiding and abetting in the abduction of Egyptian cleric Hassan Mustafa Osama Nasr (known as Abu Omar). The cleric had been kidnapped as he was walking down the street in Milan in February 2003 in what is believed to have been a joint operation by the CIA and Italian military intelligence. He was allegedly put on a plane and flown to an air base in Germany and then on to Egypt, where he claims to have been repeatedly tortured.⁵⁷²

The case, which Italian prosecutors initiated in 2003 despite strong opposition from US authorities, was brought against 26 Americans—all but one of whom were CIA officers—and seven Italian military intelligence officers.⁵⁷³ None of the Americans were ever arrested or present during the trial.⁵⁷⁴ Criminal proceedings moved forward slowly, in part due to Italian authorities' successive attempts to block the case due to concerns over its effect on US-Italian relations. The Italian government successfully challenged much of the evidence on the grounds that it might endanger national security, and refused to seek the extradition of the American defendants.

⁵⁷² "Italy/US: Italian Court Rebukes CIA Rendition Practice," Human Rights Watch news release, November 4, 2009, <http://www.hrw.org/news/2009/11/04/italyus-italian-court-rebukes-cia-rendition-practice>; "CIA agents guilty of Italy kidnap," *BBC News*, November 4, 2009, <http://news.bbc.co.uk/2/hi/europe/8343123.stm> (accessed March 30, 2015); John Hooper, "Italian court finds CIA agents guilty of kidnapping terrorism suspect," *The Guardian*, November 4, 2009, <http://www.theguardian.com/world/2009/nov/04/cia-guilty-rendition-abu-omar> (accessed April 1, 2015); Rachel Donadio, "Italy Convicts 23 Americans for C.I.A. Renditions," *New York Times*, November 4, 2009, http://www.nytimes.com/2009/11/05/world/europe/05italy.html?_r=0 (accessed April 1, 2015).

⁵⁷³ Of all the cases surveyed for this report, this is the only instance in which prosecutors opened an investigation on their own initiative without a complaint having been filed by the victim or an NGO.

⁵⁷⁴ Human Rights Watch expressed concern at the time over trials *in absentia*, which do not afford defendants an adequate opportunity to present a defense as required by the International Covenant on Civil and Political Rights, article 14. See "Italy/US: Italian Court Rebukes CIA Rendition Practice," Human Rights Watch news release. Italian law allows *in absentia* trials when there are reasons to believe the accused are aware of the trial, and are willingly refusing to participate.

The trial court convicted 22 of the CIA agents, two of the Italian military intelligence officers, and a US air force colonel. It also handed down penalties ranging from five to eight years, with the CIA's Milan station chief, Robert Seldon Lady, receiving the most serious sentence. The court ruled that the three other American defendants in the case were protected by diplomatic immunity, including the CIA's Rome station chief, Jeffrey Castelli.⁵⁷⁵ It also dismissed charges against the five remaining Italians in the case, including the former head of Italy's military intelligence service, Gen. Nicolò Pollari, on the grounds that the evidence against them was protected by the state secrecy doctrine.⁵⁷⁶

In December 2010, the Milan appeals court upheld all of the convictions but increased the sentences given to the Americans.⁵⁷⁷ In September 2012, Italy's highest court affirmed the convictions but overturned the acquittal of the five Italians and ordered them to face a new trial.⁵⁷⁸ In February 2013, two separate trials by the appeals court led to convictions of the five Italians and three US citizens who had previously been acquitted.⁵⁷⁹ Italy's highest court overturned the convictions of the five Italians in February 2014, again on the basis of the state secrecy doctrine. In March 2014, the same court upheld the three remaining CIA agents' convictions.⁵⁸⁰

⁵⁷⁵ Human Rights Watch believes the court's interpretation of diplomatic immunity was overly broad and should not have been interpreted to protect officials responsible for grave international crimes such as torture. *Ibid.*

⁵⁷⁶ Human Rights Watch took issue with the court's interpretation of the state secrecy doctrine. *Ibid.*

⁵⁷⁷ The appeals court gave Lady a nine-year prison term and seven-year terms to the other Americans. It slightly decreased the prison terms of the Italian military intelligence officers, from three years to two years and eight months. Amnesty International, "Italy/USA: Supreme Court orders re-trial of former high-level intelligence officials and upholds all convictions in Abu Omar kidnapping case," September 21, 2012, <https://www.amnesty.org/download/Documents/20000/eur300152012en.pdf> (accessed March 30, 2015).

⁵⁷⁸ "Italy/US: Ruling on CIA Case Highlights US Inaction," Human Rights Watch news release, September 20, 2012, <http://www.hrw.org/news/2012/09/20/italyus-ruling-cia-case-highlights-us-inaction>; Amnesty International, "Italy/USA: Supreme Court orders re-trial of former high-level intelligence officials and upholds all convictions in Abu Omar kidnapping case."

⁵⁷⁹ The appeals court sentenced the CIA's Rome station chief Castelli to seven years in prison and the two other CIA agents to six years. It sentenced Italy's military intelligence head Pollari to 10 years, his deputy head Marco Mancini to nine years, and the three other Italian military intelligence agents to six years each. "Italy: Continue Efforts Toward Justice for CIA Abuses," Human Rights Watch news release, July 20, 2013, <http://www.hrw.org/news/2013/07/20/italy-continue-efforts-toward-justice-cia-abuses>; "Italy's ex-spy chief convicted over 2003 CIA rendition," *BBC News*, February 12, 2013, <http://www.bbc.com/news/world-europe-21435632> (accessed March 30, 2015); Alison Sacriponte, "Italy court convicts 3 Americans for 2003 rendition kidnapping," *Jurist*, February 2, 2013, <http://jurist.org/paperchase/2013/02/italy-court-convicts-3-americans-for-2003-rendition-kidnapping.php> (accessed March 30, 2015).

⁵⁸⁰ Judith Sunderland, "Dispatches: Italy Stands Alone on Justice for CIA Abuses," Human Rights Watch dispatches, March 12, 2014, <http://www.hrw.org/news/2014/03/12/dispatches-italy-stands-alone-justice-cia-abuses>.

Regardless of whether any of the US nationals serves prison time, the case marked the first trial of US officials for CIA-related abuses post-9/11. Italian judicial authorities appear to have issued European Arrest Warrants, which are only valid in Europe, for all those convicted *in absentia*.⁵⁸¹ In July 2013, former CIA's Milan station chief Robert Seldon Lady was detained briefly in Panama on an Italian arrest warrant, and the Italian justice ministry pursued an extradition request—the only time it has done so.⁵⁸² Panamanian authorities refused the extradition request and released Lady. In October 2015, Sabrina De Sousa, a former CIA agent convicted in the case, was detained by authorities on a European Arrest Warrant issued in Italy at an airport in Lisbon as she was trying to leave the country.⁵⁸³ She was released from detention shortly thereafter and is out of custody while her extradition case is pending.⁵⁸⁴

Germany

Three criminal complaints have been filed in Germany. While Germany allows victims and NGOs to file criminal cases directly, the prosecution has wide discretion to decline to pursue them.⁵⁸⁵ The federal prosecutor's office declined to initiate an investigation in the first two cases, but has yet to decide on the third. In addition, state prosecutors issued warrants against 13 CIA agents in relation to the unlawful rendition of German national Khaled el-Masri from Macedonia in early 2004, but Germany has not taken further steps.

⁵⁸¹ Abu Omar currently has a case pending against Italy before the European Court of Human Rights for its role in his abduction and mistreatment and its failure to hold those persons responsible for the crimes against him accountable. Abu Omar challenges Italian judicial authorities' decision not to convict five Italian officials on the basis of the state secrecy doctrine and its failure to request the extradition of the US officials convicted in the case. "Italy: Court set for CIA terror abduction human rights complaint," Council of Europe news release, June 1, 2015, <http://www.humanrightseurope.org/2015/06/italy-court-set-for-cia-terror-abduction-human-rights-complaint> (accessed August 17, 2015). See also European Court of Human Rights, *Nasr v. Italy*, (44883/09), Application of Osama Mustafa Hassan Nasr and Nabila Ghali of 6 August 2009, available at <http://hudoc.echr.coe.int/sites/fra/pages/search.aspx?i=001-113123>. For more information, see Human Rights Watch, *The Legal Framework for Universal Jurisdiction in Germany*, September 2014, http://www.hrw.org/sites/default/files/related_material/IJ0914German_o.pdf.

⁵⁸² Judith Sunderland, "Dispatches: Italy Stands Alone on Justice for CIA Abuses"; Greg Miller and Karen DeYoung, "Panama releases former CIA operative wanted by Italy," *Washington Post*, July 19, 2013, http://www.washingtonpost.com/world/national-security/panama-releases-former-cia-operative-wanted-by-italy/2013/07/19/c73ebc12-f083-11e2-a1f9-ea873b7e0424_story.html (accessed March 30, 2015).

⁵⁸³ Jason Leopold, "Former CIA Officer Detained in Europe While Trying to Clear Her Name in Rendition Case," *Vice News*, October 8, 2015, <https://news.vice.com/article/former-cia-officer-detained-in-europe-while-trying-to-clear-her-name-in-rendition-case> (accessed November 6, 2015).

⁵⁸⁴ *Ibid.*

⁵⁸⁵ For more information, see Human Rights Watch, *The Legal Framework for Universal Jurisdiction in Germany*, September 2014, http://www.hrw.org/sites/default/files/related_material/IJ0914German_o.pdf.

2004 Complaint

In November 2004, CCR⁵⁸⁶ assisted four Iraqis in filing a criminal complaint against then-US Defense Secretary Donald Rumsfeld, former CIA Director George Tenet, and a number of other current and former senior military officials,⁵⁸⁷ for alleged torture and other ill-treatment amounting to war crimes suffered at the hands of US armed forces in the Abu Ghraib prison in Iraq.⁵⁸⁸ US officials expressed concern over the case, warning that “frivolous lawsuits” could adversely affect the US relationship with Germany.⁵⁸⁹ Through the US embassy, Rumsfeld also informed German authorities that he would not take part in an upcoming Conference on Security Policy in Munich if the case proceeded.⁵⁹⁰

On February 10, 2005, just days before Rumsfeld was scheduled to speak at the security conference in Munich, the federal prosecutor’s office announced that it would not pursue an investigation.⁵⁹¹ The office justified its decision on the grounds of subsidiarity, asserting that there were no indications the US was refraining from investigating and prosecuting the crimes in the US. Emphasizing that the US had a closer connection to the alleged crimes, the federal prosecutor’s office said that it need not look at whether Rumsfeld was himself under investigation in the United States or whether the exact same crimes were being investigated.⁵⁹² ECCHR and CCR challenged the decision, but the appeals court declared

⁵⁸⁶ The complaint was filed by ECCHR executive director Wolfgang Kaleck when working for CCR, prior to ECCHR’s founding.

⁵⁸⁷ These officials included Lt. Gen. Ricardo Sanchez, Commander of the Combined Joint Task Force Seven at Abu Ghraib; Maj. Gen. Walter Wojdakowski, Dep. Commanding Gen. of the Combined Joint Task Force Seven at Abu Ghraib; Brig. Gen. Janis Karpinski, Commander of the 800th Military Police Brigade at Abu Ghraib; Lt. Col. Jerry Phillabaum, Commander of the 320th Military Police Brigade at Abu Ghraib; Col. Thomas Pappas, Commander of the 205th Military Intelligence Brigade at Abu Ghraib; Lieutenant Colonel Stephen L. Jordan, Chief of the Joint Interrogation Debriefing Center at Abu Ghraib; Maj. Gen. Geoffrey Miller, Commander of the Joint Task Force at Guantanamo; and Under Sec. of Defense for Intelligence Stephen Cambone.

⁵⁸⁸ The complaint alleged that the torture and ill-treatment of detainees amounted to a war crime under the German Code of Crimes against International Law. For more details on the case, see European Center for Constitutional and Human Rights (ECCHR), “Rumsfeld torture cases,” undated, http://www.ecchr.eu/en/our_work/international-crimes-and-accountability/u-s-accountability/rumsfeld.html (accessed March 23, 2015).

⁵⁸⁹ “Lawsuit against Rumsfeld threatens US-German Relations,” *Deutsche Welle*, December 14, 2004, <http://www.dw.de/lawsuit-against-rumsfeld-threatens-us-german-relations/a-1427743> (accessed June 3, 2015).

⁵⁹⁰ Adam Zagorin, “Exclusive: Charges Sought Against Rumsfeld Over Prison Abuse,” *Time*, November 10, 2006, <http://content.time.com/time/nation/article/0,8599,1557842,00.html> (accessed April 29, 2015); “Pentagon concerned about legal complaint in Germany against Rumsfeld, others,” *Agence France Presse*, December 13, 2004.

⁵⁹¹ “Germany Won’t Prosecute Rumsfeld,” *Deutsche Welle*, February 10, 2005. See also “Keine deutschen Ermittlungen wegen der angezeigten Vorfälle von Abu Ghraib/Irak,” Federal Prosecutor’s Office press release, February 10, 2005, <https://www.generalbundesanwalt.de/de/showpress.php?newsid=163> (accessed March 23, 2015).

⁵⁹² The federal prosecutor’s office argued that the *complex* of crimes was under investigation so it need not look at whether the same accused and the exact same crimes were the subject of criminal proceedings in the US. “Keine deutschen Ermittlungen wegen der angezeigten Vorfälle von Abu Ghraib/Irak,” Federal Prosecutor’s Office press release.

the request for review inadmissible, including on the basis that the prosecutor did not abuse discretion in declining to move forward.⁵⁹³

In July 2006, the UN Special Rapporteur on the independence of judges and lawyers sent a letter to German authorities expressing concern over the prosecutor's decision. Noting the "strong political pressure" exerted by the US and the questionable timing of the decision, the letter alleged a violation of the independence of the judiciary.⁵⁹⁴ The Special Rapporteur underlined that there were no indications that US judicial authorities were actually investigating the alleged crimes, with the exception of low-ranking officers, or had any intention to look at criminal responsibility of senior military officials. He also took issue with the prosecutor's cursory decision dismissing the complaint.⁵⁹⁵

2006 Complaint

In November 2006, just days after Rumsfeld had resigned as defense secretary, CCR⁵⁹⁶ filed another complaint with the German federal prosecutor's office on behalf of Guantanamo detainee Mohammed al-Qahtani and 11 Iraqis who had been held at Abu Ghraib.⁵⁹⁷ The complaint targeted Rumsfeld, Tenet, and other current and former senior military officials,⁵⁹⁸ but also included current and former government attorneys Alberto Gonzales, William Haynes, David Addington, John Yoo, and Jay Bybee.⁵⁹⁹ Like the earlier complaint, it alleged that the defendants had committed war crimes by justifying, ordering, and implementing abusive interrogation policies that resulted in torture of the 12 individuals.

⁵⁹³ *CCR et al. v. Donald Rumsfeld et al.*, Higher Regional Court of Stuttgart, Case No. 5 Ws 109/05, Decision, September 13, 2005, http://www.ecchr.eu/de/unsere-themen/voelkerstrafataten-und-rechtliche-verantwortung/usa/rumsfeld.html?file=tl_files/Dokumente/Universelle%2520Justiz/%2520Entscheidung_OLG_Stuttgart_Klageerzwingungsverfahren.pdf (accessed March 23, 2015). See also Katherine Gallagher, "Efforts to Hold Donald Rumsfeld and Other High-Level United States Officials Accountable for Torture," *Journal of International Criminal Justice*, vol. 7, no. 5 (2009): 1105-1106, <http://jicj.oxfordjournals.org/content/7/5/1087.full.pdf+html> (accessed April 30, 2015).

⁵⁹⁴ UN Commission on Human Rights, Report of the Special Rapporteur on the independence of judges and lawyers, A/HRC/4/25/Add.1, April 5, 2007, pp. 96-98.

⁵⁹⁵ *Ibid.*, pp. 97-98.

⁵⁹⁶ The complaint was filed by ECCHR executive director Wolfgang Kaleck when working for CCR, prior to ECCHR's founding.

⁵⁹⁷ CCR, "German War Crimes Complaint against Donald Rumsfeld, et al." undated, <http://ccrjustice.org/ourcases/current-cases/german-war-crimes-complaint-against-donald-rumsfeld-et-al> (accessed March 30, 2015).

⁵⁹⁸ These officials included Under Sec. of Defense for Intelligence Stephen Cambone; Lt. Gen. Ricardo Sanchez, commander of Combined Joint Task Force Seven at Abu Ghraib; Maj. Gen. Geoffrey Miller, commander of Joint Task Force Guantanamo; Col. Thomas Pappas, commander of the 205th Military Intelligence Brigade at Abu Ghraib; Maj. Gen. Walter Wojdakowski, deputy commanding general of Combined Joint Task Force Seven at Abu Ghraib; Maj. Gen. Barbara Fast, senior intelligence officer at Abu Ghraib; and Col. Marc Warren, staff judge advocate for Coalition Forces in Iraq.

⁵⁹⁹ CCR, "German War Crimes Complaint against Donald Rumsfeld, et al."

The complaint documented how no meaningful investigations had taken place in the US or Iraq and provided lengthy submissions. It was supported by numerous human rights and civil society organizations, international legal scholars, and a former UN Special Rapporteur on Torture. In addition, former Army Brig. Gen. Janis Karpinski, who had been a defendant in the 2004 case in relation to her role as commander of the 800th Military Police Brigade at Abu Ghraib, submitted written testimony in support and offered to appear as a witness.⁶⁰⁰

On April 27, 2007, the federal prosecutor's office again decided not to open an investigation. This time the federal prosecutor focused less on the issue of subsidiarity and more on whether there were sufficient links to Germany to merit an investigation. She concluded that none of the suspects resided in Germany or could be expected to come there.

The prosecutor also concluded that any investigation was likely to be unsuccessful because US authorities would not cooperate with the case.⁶⁰¹ She said: "To resolve possible accusations, investigation on the scene and in the United States of America would be unavoidable. Because the German investigative authorities have no executive powers abroad, this could only occur through legal assistance. But such requests are obviously futile—especially if we consider the legal and security situation in Iraq."⁶⁰²

The complainants filed a challenge with the court, asserting that an investigation could take place even in the absence of the accused, but the petition for review was again dismissed. The court held that, while the possibility of former US officials coming to Germany could not be excluded, it was not a sufficient basis to compel an investigation.⁶⁰³

⁶⁰⁰ Testimony of Former US Brigadier General Janis Karpinski, Former Head of Abu Ghraib, for the German criminal procedure against DOD Donald Rumsfeld and others, October 26, 2005, <http://ccrjustice.org/files/abu%20KarpinskiTestimony2006.pdf> (accessed April 30, 2015).

⁶⁰¹ "Kein Ermittlungsverfahren wegen der angezeigten Vorfälle in Abu Ghraib/Irak und in Guantánamo Bay/Kuba," Federal Prosecutor's Office press release, April 27, 2007, <http://www.generalbundesanwalt.de/de/showpress.php?themenid=9&newsid=273>, English translation, <https://www.fidh.org/International-Federation-for-Human-Rights/americas/usa/USA-Guantanamo-Abu-Ghraib/GERMAN-FEDERAL-PROSECUTOR-S-OFFICE> (accessed June 10, 2015). Criminal Complaint against Donald Rumsfeld et al., Federal Supreme Court of Karlsruhe, Case No. 3 ARP 156/06-2, Decision, April 5, 2007, <http://ccrjustice.org/files/ProsecutorsDecision.pdf> (accessed March 23, 2015).

⁶⁰² Criminal Complaint against Donald Rumsfeld et al., Federal Supreme Court of Karlsruhe, Case No. 3 ARP 156/06-2, Decision, April 5, 2007, p. 7.

⁶⁰³ *Derweesh et al. v. Donald Rumsfeld et al.*, Higher Regional Court of Stuttgart, Case No. 3 ARP 156/06-2, Decision, April 21, 2009, <http://ccrjustice.org/files/Beschluss%20OLG%20Stuttgart.pdf> (accessed March 23, 2015).

2014 Complaint

On December 17, 2014, following the release of the Senate Summary, ECCHR filed a third complaint against Rumsfeld, Tenet, and other “alleged perpetrators in senior positions within the Department of Defense, the Department of Justice, the CIA and other departments” with German federal prosecutors.⁶⁰⁴ Unlike the 2004 and 2006 complaints, this complaint has not been filed on behalf of specific victims. The allegations are similar to those contained in the earlier complaints, namely that US authorities conceived of and implemented a program of torture that was carried out by CIA, military, and other US officials.⁶⁰⁵

The federal prosecutor’s office has not yet decided whether to open an investigation. Since the 2004 and 2006 cases were dismissed, universal jurisdiction has gained growing acceptance in Germany, as evidenced by the creation of a specialized war crimes unit in 2009 and the opening of broad preliminary investigations—known as “structural investigations”—into grave crimes committed abroad, including in Libya and Syria, which have little direct link to Germany.⁶⁰⁶ In addition, as discussed above, the federal prosecutor’s office has changed its internal policy and now only exercises discretion where a suspect is not ever likely to come to Germany *and* where no potential victims and witnesses can be identified in the country.⁶⁰⁷ German officials told Human Rights Watch in March 2014, prior to the filing of the most recent complaint, that the earlier *Rumsfeld* cases might be decided differently now.⁶⁰⁸ Victims and witnesses to certain US abuses committed in Iraq and Guantanamo are believed to be living in Germany. Federal prosecutors should open a structural investigation and take steps to gather and preserve evidence that could be used in later criminal proceedings in Germany or elsewhere.

⁶⁰⁴ “Criminal complaint against Bush era architects of torture,” ECCHR, http://www.ecchr.eu/en/our_work/international-crimes-and-accountability/u-s-accountability/germany.html (accessed November 6, 2015).

⁶⁰⁵ Criminal Complaint by ECCHR against George Tenet, Donald Rumsfeld, et al., Karlsruhe Federal Court of Justice, December 17, 2014, (accessed November 6, 2015).

⁶⁰⁶ See also “DR Congo: German Court Convicts Two Rwandan Rebel Leaders,” Human Rights Watch news release, September 28, 2015, <https://www.hrw.org/news/2015/09/28/dr-congo-german-court-convicts-two-rwandan-rebel-leaders>. In addition, for more information on “structural investigations” and the work of specialized war crimes units in Germany, see Human Rights Watch, *The Long Arm of Justice*, pp. 52-55, 58-60.

⁶⁰⁷ *Ibid.*, pp. 58-59. Human Rights Watch interview with German officials, March 18, 2014. See also “Zehn Jahre Völkerstrafgesetzbuch,” German Parliament, November 7, 2012, <http://dip21.bundestag.de/dip21/btd/17/113/1711339.pdf> (accessed April 30, 2015), question 11.

⁶⁰⁸ Human Rights Watch interview with German officials, March 18, 2014.

Khaled El-Masri Case

In June 2004, Munich state prosecutors opened a criminal investigation into allegations that German national Khaled el-Masri had been a victim of the CIA rendition, detention, and interrogation program. El-Masri's case was one of the most documented unlawful rendition and torture cases, and it was the first such case to be heard by the European Court of Human Rights (ECtHR).

In December 2003, Macedonian border guards arrested el-Masri while he was crossing by bus into Macedonia from Serbia. He was detained in Macedonia for several weeks and then turned over to CIA agents and flown to Afghanistan, where he was tortured for several months. Eventually the CIA dropped him off in Albania without charging him with any crime and he returned to Germany.⁶⁰⁹

In January 2007, Munich prosecutors issued arrest warrants for 13 CIA agents on charges of wrongful imprisonment and causing serious bodily harm to el-Masri.⁶¹⁰ The case was initiated at the state level, rather than the federal level, because the allegations did not include torture as a war crime.⁶¹¹ The case strained US-Germany relations, with prosecutors citing lack of cooperation from US authorities.⁶¹² US diplomatic cables released by WikiLeaks revealed that US authorities warned German officials that pursuing the arrest warrants and extradition of those accused would “have a negative impact on our bilateral relationship.”⁶¹³ In the end, the German government never sought the suspects’

⁶⁰⁹ For more information, see European Court of Human Rights, *El-Masri v. The Former Yugoslav Republic of Macedonia*, (39630/09), Judgment of 13 December 2012, available at <http://hudoc.echr.coe.int/sites/eng/pages/search.aspx?i=001-115621>. See also “Litigation: El-Masri v. Macedonia,” OSJI, last modified January 23, 2013, <http://www.opensocietyfoundations.org/litigation/el-masri-v-macedonia> (accessed March 31, 2015).

⁶¹⁰ “Germany issues arrest warrants for suspected CIA agents,” *The Guardian*, January 31, 2007, <http://www.theguardian.com/world/2007/jan/31/usa.germany> (accessed March 23, 2015); Mark Landler, “German Court Seeks Arrest of 13 C.I.A. Agents,” *New York Times*, January 31, 2007, http://www.nytimes.com/2007/01/31/world/europe/31cnd-germany.html?_r=0 (accessed April 20, 2015); “Germany Issues Arrest Warrants for 13 CIA Agents in El-Masri Case,” *Der Spiegel*, January 31, 2007, <http://www.spiegel.de/international/el-masri-kidnapping-case-germany-issues-arrest-warrants-for-13-cia-agents-in-el-masri-case-a-463385.html> (accessed March 23, 2015).

⁶¹¹ Torture may be considered a constituent act of war crimes or crimes against humanity under German law but is not defined as a separate crime. It can therefore only be prosecuted as an “ordinary” crime and falls within the jurisdiction of state prosecutors. Human Rights Watch, *The Legal Framework for Universal Jurisdiction in Germany*, p. 1.

⁶¹² Craig Whitlock, “German Lawmakers Fault Abduction Probe,” *Washington Post*, October 4, 2006, <http://www.washingtonpost.com/wp-dyn/content/article/2006/10/03/AR2006100301449.html> (accessed March 30, 2015).

⁶¹³ US State Department cable, “Al-Masri Case – Chancellery Aware of USG Concerns,” February 6, 2007, https://wikileaks.org/plusd/cables/07BERLIN242_a.html (accessed April 30, 2015); Letta Taylor (Human Rights Watch), “Time to Clean House on Torture,” commentary, *The Guardian*, December 3, 2010, <http://www.hrw.org/news/2010/12/03/time-clean-house-torture>.

extradition. While prosecutors have taken no further steps, the arrest warrants remain outstanding, which means that the suspects could face arrest if they travel to Germany or other European countries.⁶¹⁴

On December 12, 2012, the ECtHR found that el-Masri had been tortured and held Macedonia responsible for his torture and ill-treatment both within the country itself and after his transfer to US authorities.

In December 2014, after the release of the Senate Summary, ECCHR wrote to the German Minister of Justice to urge Germany to request the extradition of the 13 CIA agents and to seek an apology and compensation for el-Masri from US authorities.⁶¹⁵ In July 2015 ECCHR filed a criminal complaint with the German federal prosecutor against Alfreda Bikowsky, a CIA agent connected to el-Masri's CIA rendition, torture, and continued detention months after his mistaken identity had been realized.⁶¹⁶ The complaint was connected to its December 17, 2014 complaint against Tenet, Rumsfeld and others. In October it made another submission in support of the complaint.⁶¹⁷ Should the German federal prosecutor not launch a criminal investigation, ECCHR plans to file a criminal complaint against Bikowsky with the Munich state prosecutor that issued the arrest warrants for the 13 CIA officials charged in el-Masri's case.⁶¹⁸

France

Victims and NGOs have filed criminal complaints in France in connection with alleged torture and other abuses in Guantanamo, Iraq, and Afghanistan. Under French law, victims and other affected parties, including nongovernmental organizations, can file a criminal

⁶¹⁴ ECCHR, "Piecing together the puzzle: making US torturers in Europe accountable," September 2014, <http://www.statewatch.org/analyses/no-256-torture-schuller-fajana.pdf> (accessed March 23, 2015).

⁶¹⁵ "Germany must enforce criminal prosecution of CIA agents and demand an apology and compensation for CIA victim El Masri," ECCHR news release, December 15, 2014, http://www.ecchr.de/el_masri_case.html (accessed June 9, 2015). Amnesty has supported ECCHR's call to re-open the investigation into its own role in the CIA torture program. Amnesty International, "Breaking the Conspiracy of Silence: USA's European 'Partners in Crime' Must Act After Senate Torture Report," January 2015, <https://www.amnesty.org/download/Documents/212000/euro10022015en.pdf> (accessed April 30, 2015), p. 23.

⁶¹⁶ Elisabeth Braw, "German human rights group files complaint against CIA 'Queen of Torture,'" *Al Jazeera America*, October 19, 2015, <http://america.aljazeera.com/articles/2015/10/19/in-germany-cia-official-charged-with-torture.html> (accessed November 6, 2015).

⁶¹⁷ Ibid. See also "Criminal complaint against Bush era architects of torture," ECCHR, http://www.ecchr.eu/en/our_work/international-crimes-and-accountability/u-s-accountability/germany.html (accessed November 6, 2015).

⁶¹⁸ Elisabeth Braw, "German human rights group files complaint against CIA 'Queen of Torture,'" *Al Jazeera*.

complaint directly with investigative judges rather than passing through prosecutors to ensure that a judicial investigation is opened.⁶¹⁹ An investigation remains pending in one case, but prosecutors declined to open an investigation against former Defense Secretary Donald Rumsfeld on the grounds that he had immunity.

Guantanamo Detainees Case

In November 2002, the parents of two French citizens who were detained at Guantanamo, Nizar Sassi and Mourad Benchellali, filed a criminal complaint before French courts alleging unlawful detention by US officials.⁶²⁰ A judge in Lyon declined to investigate, which was upheld by an appeals court. In January 2005, however, France's highest court reversed the decision, and an investigation was opened in June 2005.⁶²¹

In June 2006, a third French citizen, Khaled Ben Mustapha, who had also been held at Guantanamo, joined the case, alleging that he had been a victim of kidnapping and torture by US officials.⁶²² In January 2012, the investigative judge submitted a formal request to US authorities for access to the Guantanamo Bay detention center, all documents relevant to the detention of the three French citizens, and the names of anyone who had contact with them during their detention.⁶²³ The US never responded to the request.⁶²⁴

In February 2014, the former detainees' lawyer filed an expert report aimed at establishing the criminal responsibility of former Guantanamo commander Geoffrey Miller and

⁶¹⁹ For more information, see Human Rights Watch, *The Legal Framework for Universal Jurisdiction in France*, September 2014, http://www.hrw.org/sites/default/files/related_material/110914France_3.pdf, pp. 4-6.

⁶²⁰ The complaint did not name specific defendants, which is permitted under French law. "La plainte des familles de Mourad Benchellali et Nizar Sassi doit être à nouveau examinée," *mLyon*, January 4, 2005, <http://www.mlyon.fr/19116-la-plainte-des-familles-de-mourad-benchellali-et-nizar-sassi-doit-etre-a-nouveau-examinee.html> (accessed April 21, 2015).

⁶²¹ European Court of Human Rights, *Sassi and Benchellali v. France*, (21015/05), Judgment of 27 September 2005, available at <http://jurisprudence.cedh.globe24h.com/o/o/france/2007/09/27/sassi-et-benchellali-c-france-82780-21015-05.shtml>; Letter from Patrick Baudouin, lawyer for the complainants and Honorary President of FIDH, to Jean-Claude Marin, Public Prosecutor, Office of the Prosecutor of the Paris Court of Appeal, October 25, 2007, <https://www.fidh.org/IMG/pdf/plainteFINALE25oct07.pdf> (accessed April 21, 2015), pp. 11-12.

⁶²² As authorized under French law, Khaled Ben Mustapha's complaint also did not name specific defendants. "Plainte d'un ancien détenu français de Guantanamo pour enlèvement et torture," *NewsML*, June 23, 2006, http://newsml.cwi.nl/internal/data/NewsFeed_FR-2006/06/23/afp.com-20060623T163612Z-TX-SGE-JWM75.xml (accessed April 21, 2015).

⁶²³ "French Court Investigating U.S. Torture: Summon Former Gitmo Commander," CCR press release, April 2, 2015, <http://ccrjustice.org/newsroom/press-releases/french-court-investigating-u.s.-torture%3A-summons-former-gitmo-commander> (accessed April 21, 2015).

⁶²⁴ *Ibid.*; ECCHR, "Piecing together the puzzle: making US torturers in Europe accountable," September 2014.

requested that Miller be subpoenaed to testify.⁶²⁵ In April 2014, the investigative judges declined the request on the grounds that US authorities would not cooperate or make Miller available for questioning. The former detainees appealed this decision.⁶²⁶ On April 2, the appeals court reversed the decision and ordered the lower court to summon Miller to explain his role in the alleged abuse of the former detainees.⁶²⁷

Rumsfeld Case

In late October 2007, on the eve of a visit by Donald Rumsfeld to Paris for an event on foreign policy, the International Federation for Human Rights (FIDH), ECCHR, CCR, and the French League for Human Rights filed a complaint with French prosecutors alleging that Rumsfeld bears criminal responsibility for torture and other ill-treatment committed in US-run detention facilities in Guantanamo, Iraq, and Afghanistan.⁶²⁸ Former Army Brigadier General Janis Karpinski submitted written testimony in support of the complaint as she had in Germany a year earlier.⁶²⁹ Rumsfeld traveled to Paris as planned and faced no judicial consequences.⁶³⁰

The following month, the Paris district prosecutor formally dismissed the complaint without addressing the merits. Relying on an opinion from the foreign ministry, he concluded that Rumsfeld had immunity from prosecution based on his former position as US defense secretary.⁶³¹ The NGOs urged the general prosecutor to reconsider this

⁶²⁵ CCR and ECCHR, Joint Expert Opinion before the Appeals Court in Paris (Tribunal de Grande Instance, Cour d'Appel de Paris), Case No. 2275/05/10, February 26, 2014, http://ccrjustice.org/files/MILLER-DOSSIER-FINAL_en_20140226_public.pdf (accessed March 23, 2015).

⁶²⁶ "Rights Groups Urge French Appeals Court to Subpoena Former Guantánamo Commander in Torture Investigation," CCR press release, March 5, 2015, <http://ccrjustice.org/home/press-center/press-releases/rights-groups-urge-french-appeals-court-subpoena-former-guant-namo> (accessed June 10, 2015).

⁶²⁷ "French Court Investigating U.S. Torture: Summon Former Gitmo Commander," CCR press release.

⁶²⁸ Letter from Patrick Baudouin, lawyer for the complainants and Honorary President of FIDH, to Jean-Claude Marin, Public Prosecutor, Office of the Prosecutor of the Paris Court of Appeal, October 25, 2007. For a summary of the case, see CCR, "French War Crimes Complaint against Donald Rumsfeld, et al." undated, <http://ccrjustice.org/ourcases/current-cases/french-war-crimes-complaint-against-donald-rumsfeld> (accessed March 23, 2015).

⁶²⁹ Testimony of Former US Brigadier General Janis Karpinski, Former Head of Abu Ghraib, for the French criminal procedure against former American Secretary of Defense Donald Rumsfeld, October 24, 2007, https://www.fidh.org/IMG/pdf/doc_20_-_Karpinski_Testimony.pdf (accessed April 30, 2015).

⁶³⁰ "Visite mouvementée de Donald Rumsfeld à Paris," *Courrier International*, October 26, 2007, <http://www.courrierinternational.com/article/2007/10/26/visite-mouvementee-de-donald-rumsfeld-a-paris> (accessed June 15, 2015).

⁶³¹ Letter from Jean-Claude Marin, Public Prosecutor, Office of the Prosecutor of the Paris Court of Appeal, to Patrick Baudouin, lawyer for the complainants and Honorary President of FIDH, November 16, 2007, <http://www.fidh.org/IMG/pdf/reponseproc23nov07.pdf> (accessed March 23, 2015).

decision, but in February 2008 he confirmed the granting of immunity on the grounds that the alleged conduct could not “be dissociated” from Rumsfeld’s official function.⁶³²

The prosecutors’ decisions rested on an interpretation of the International Court of Justice’s (ICJ) decision in the *Arrest Warrant (Democratic Republic of Congo v. Belgium)* case and another decision by France’s highest court.⁶³³ The ICJ ruled that certain foreign government officials are entitled to temporary immunity from prosecution by foreign states, even with regards to grave international crimes. Many advocates, including Human Rights Watch, interpret the judgment not to bar later prosecutions for grave international crimes, however. In addition, the prosecutors’ decisions to grant Rumsfeld immunity ignore contrary international precedent, including the *Nuremberg* and *Pinochet* cases, which have held that torture and war crimes cannot be legitimate functions of a government official, and numerous international tribunal statutes, which unequivocally state that official capacity does not exempt a person from criminal responsibility for grave international crimes.⁶³⁴

⁶³² Letter from Patrick Baudouin, lawyer for the complainants and Honorary President of FIDH, to Jean-Claude Marin, Public Prosecutor, Office of the Prosecutor of the Paris Court of Appeal, November 23, 2007, http://www.fidh.org/IMG/pdf/courrier_REPONSE_FIDH-LDH-CCR-ECCHR-JCMARIN-23nov07.pdf (accessed March 23, 2015); Letter from Jean-Claude Marin, Public Prosecutor, Office of the Prosecutor of the Paris Court of Appeal, to Patrick Baudouin, lawyer for the complainants and Honorary President of FIDH, February 27, 2008, http://ccrjustice.org/files/Rumsfeld_FrenchCase_%20Prosecutors%20Decision_02_08.pdf (accessed March 23, 2015).

⁶³³ *The Democratic Republic of Congo v. Belgium*, International Court of Justice, Judgment, February 14, 2002, <http://www.icj-cij.org/docket/index.php?p1=3&p2=3&case=121&p3=4> (accessed March 23, 2015); *In the Appeal of the Prosecutor General*, Supreme Court of France, Criminal Chamber, Case No. 00-87.215, Judgment, March 13, 2001, <http://www.legifrance.gouv.fr/affichJuriJudi.do?idTexte=JURITEXT000007070643> (accessed March 23, 2015). See also “A retrograde decision and a dangerous precedent!” FIDH news release, March 14, 2001, <https://www.fidh.org/International-Federation-for-Human-Rights/north-africa-middle-east/libya/A-retrograde-decision-and-a> (accessed March 23, 2015).

⁶³⁴ *The United States v. Otto Ohlendorf*, IV, Trials of War Criminals Before the Nuremberg Military Tribunals Under Control Council Law No. 10 (“Nuremberg Judgment”), 1950, p. 411; *R. v. Bow Street Metropolitan Stipendiary Magistrate, ex parte Pinochet*, House of Lords, [2000] 1 A.C. 147, Opinion of Lord Browne-Wilkinson, March 24, 1999, <http://www.bailii.org/uk/cases/UKHL/1999/17.html> (accessed March 30, 2015). See also Rome Statute of the International Criminal Court (Rome Statute), A/CONF.183/9, July 17, 1998, entered into force July 1, 2002; Statute of the International Tribunal for the Prosecution of Persons Responsible for Violations of International Humanitarian Law Committed in the Territory of the Former Yugoslavia Since 1991 (ICTY Statute), adopted by Security Council May 25, 1993, U.N. Doc. S/RES/827; Statute of the International Criminal Tribunal for Rwanda (ICTR Statute), adopted by Security Council November 8, 1994, U.N. Doc. S/Res/955; Charter of the International Military Tribunal - Annex to the Agreement for the prosecution and punishment of the major war criminals of the European Axis (“London Agreement”), August 8, 1945, <http://www.refworld.org/cgi-bin/texis/vtx/nwmain?docid=3ae6b39614> (accessed May 25, 2015).

Spain

Spanish judicial authorities have opened three cases into alleged torture and other serious abuses, but all three have either been stayed or dismissed (appeals are pending in all three cases). US authorities vigorously opposed the cases.⁶³⁵ US diplomatic cables in 2009 suggest that US embassy officials, joined by some members of Congress, tried to influence the Spanish judicial process in order to obtain the dismissal of the cases, and that Spanish officials bowed to pressure by US officials.

“The Bush Six”

In March 2009, the Association for the Dignity of Spanish Prisoners filed a criminal complaint against six former Bush administration lawyers, including Alberto Gonzales, David Addington, William Haynes, John Yoo, Jay Bybee, and Douglas Feith. The complaint alleged that the US government committed torture and war crimes against several former Guantanamo detainees, including five individuals who were either Spanish citizens or residents of Spain,⁶³⁶ as a result of the legal advice provided by the six defendants.⁶³⁷ Investigative judge Baltasar Garzón, who issued the historic arrest warrant against Pinochet in 1998, found the case admissible. However, following opposition from Spain’s Attorney General, Garzón submitted the case for reassignment to another judge.⁶³⁸

Since Spanish courts have subsidiary jurisdiction (meaning they can only hear cases in which the courts of the country where the crimes occurred have not initiated criminal proceedings), the new investigative judge sent a formal request to US authorities in May 2009 asking for confirmation of whether an investigation into the allegations was being

⁶³⁵ Giles Tremlett, “Wikileaks: US pressured Spain over CIA rendition and Guantánamo torture,” *The Guardian*, December 1, 2010, <http://www.theguardian.com/world/2010/nov/30/wikileaks-us-spain-guantanamo-rendition> (accessed June 3, 2015).

⁶³⁶ The Spanish detainees represented by the Association for the Dignity of Spanish Prisoners included Hamed Abderrahman Ahmed, Reswad Abdulsam, Lahcen Ikassrien, Jamiel Abdul Latif al Banna, and Omar Deghayes.

⁶³⁷ Criminal Complaint by CCR against Alberto Gonzales, David Addington, William Haynes, John Yoo, Jay Bybee, and Douglas Feith, Madrid National Court, March 17, 2009,

https://ccrjustice.org/sites/default/files/assets/Bush%20Six_complaint_spanish_o.pdf (accessed May 25, 2015); Human Rights Watch, *Getting Away with Torture: The Bush Administration and Mistreatment of Detainees*, July 2011,

http://www.hrw.org/sites/default/files/reports/uso711webwcover_1.pdf, pp. 100-101; Gallagher, “Efforts to Hold Donald Rumsfeld and Other High-Level United States Officials Accountable for Torture”; Julian Borger and Dale Fuchs, “Spanish Judge to Hear Torture Case against Six Bush Officials,” *The Guardian*, March 29, 2009,

<http://www.theguardian.com/world/2009/mar/29/guantanamo-bay-torture-inquiry> (accessed April 28, 2015).

⁶³⁸ US State Department cable, “Garzon opens second investigation into alleged US Torture of Terrorism Detainees,” May 5, 2009.

conducted.⁶³⁹ After the judge set a deadline for the US to respond,⁶⁴⁰ US authorities finally answered on March 1, 2011, asserting that they had completed several prosecutions and that Assistant US Attorney John Durham was continuing his investigation into alleged detainee abuse. The US also claimed that there was no basis for prosecuting Yoo or Bybee as they had already been investigated and cleared of responsibility by an ethics body.⁶⁴¹ The Spanish judge stayed proceedings and sent the case to the US Department of Justice for further action asking only that the US inform it, at the relevant time, of the measures it ultimately may adopt as a result of the case's transfer.⁶⁴² The Association for the Dignity of Spanish Prisoners, joined by two additional NGOs, challenged the decision but both the appeals court and the Supreme Court denied the appeal.⁶⁴³ In March 2013, the Association filed a petition for review with the Spanish Constitutional Court, which remains pending.⁶⁴⁴

Guantanamo Detainees Case

In April 2009, just weeks after the “Bush Six” complaint had been filed, Judge Garzón opened a preliminary investigation into related allegations concerning Guantanamo. The investigation named no specific defendants, but focused on allegations put forward by four of the former Guantanamo detainees named in the “Bush Six” case: Hamed Abderrahman Ahmed, Lahcen Ikassrien, Jamiel Abdul Latif al Banna, and Omar

⁶³⁹ Central Court for Preliminary Criminal Proceedings Number Six, Madrid National Court, Case No. 134/2009, Decision (Preliminary Investigation), May 4, 2009, unofficial English translation, [http://ccrjustice.org/files/Bush%20Six%20Order%20Rogatory%20Letter%20English%20\(2\).pdf](http://ccrjustice.org/files/Bush%20Six%20Order%20Rogatory%20Letter%20English%20(2).pdf) (accessed March 30, 2015).

⁶⁴⁰ Central Court for Preliminary Criminal Proceedings Number Six, Madrid National Court, Case No. 134/2009, Judicial Order (Preliminary Investigation), January 28, 2011, unofficial English translation, <http://ccrjustice.org/files/28%20January%202011%20Order%20English.pdf> (accessed March 30, 2015).

⁶⁴¹ Central Court Number Six for Preliminary Criminal Proceedings, Madrid National Court, Case No. 134/2009, US Department of Justice Response (Preliminary Investigation), March 1, 2011, <http://ccrjustice.org/files/US%20Letters%20Rogatory%20Response%20March%201,%202011%20-%20ENG.pdf> (accessed March 30, 2015).

⁶⁴² Central Court for Preliminary Criminal Proceedings Number Six, Madrid National Court, Case No. 134/2009, Judicial Order (Preliminary Investigation), April 13, 2011, unofficial English translation, <http://ccrjustice.org/files/13%20April%202011%20Order%20ENG.pdf> (accessed March 30, 2015).

⁶⁴³ Spanish Supreme Court of Justice, Criminal Chamber, Case No. 1916/2012, Decision, December 20, 2012, unofficial English translation, <http://ccrjustice.org/files/2012-12-20%20Spanish%20National%20Court%20Decision%20Final%20English.pdf> (accessed March 30, 2015).

⁶⁴⁴ Petition to the Spanish Constitutional Court, March 22, 2013, unofficial English translation, [http://ccrjustice.org/files/2013-03-22%20ENG%20Application%20for%20amparo%20\[2\]\[1\]\[971\]\[0978\].pdf](http://ccrjustice.org/files/2013-03-22%20ENG%20Application%20for%20amparo%20[2][1][971][0978].pdf) (accessed March 30, 2015).

Deghayes.⁶⁴⁵ The Human Rights Association of Spain (APDHE) is a civil party in the case.⁶⁴⁶

In May 2009, Judge Garzón issued formal requests to US and UK authorities to determine whether any investigations were pending with respect to the four individuals.⁶⁴⁷ Neither country responded.⁶⁴⁸

Meanwhile, in October 2009, Spain's Parliament amended its laws to restrict jurisdiction to cases with a demonstrated link to Spain. Consequently, cases would only be admissible where the victim is a Spanish national, the suspect is present in Spain, or some other legitimizing link to the country exists.⁶⁴⁹ The change in law did not mean an end to the Guantanamo investigation, however, as one of the victims was a Spanish citizen, another was a Spanish resident, and Spain had previously requested the extradition of all four in connection with an unrelated criminal case.⁶⁵⁰ Even without these links, Judge Garzón found that jurisdiction would have existed because of Spain's international obligations to investigate and prosecute both torture and war crimes.⁶⁵¹

⁶⁴⁵ The investigation targeted those who “approved [the] systematic plan of torture and ill-treatment.” Central Court for Preliminary Criminal Proceedings Number Five, Madrid National Court, Case No. 150/2009, Judicial Order (Preliminary Investigation), April 27, 2009, unofficial English translation, http://ccrjustice.org/files/Unofficial%20Translation%20of%20the%20Spanish%20Decision%2004-27-2009_o.pdf (accessed March 30, 2015).

⁶⁴⁶ Asociación Pro Derechos Humanos de España (APDHE), “Qué Hacemos,” undated, <http://www.apdhe.org/tras-la-reforma-de-la-justicia-universal-el-juzgado-central-de-instruccion-no-5-de-la-audiencia-nacional-decide-proseguir-con-la-investigacion-del-caso-de-genocidio-en-el-sahara-occidental-y-del-cas/> (accessed August 18, 2015).

⁶⁴⁷ Central Court for Preliminary Criminal Proceedings Number Five, Madrid National Court, Case No. 150/2009, Decision (Preliminary Investigation), May 26, 2009, unofficial English translation, <http://ccrjustice.org/files/May%202009%20Letter%20Rogatory%20English.pdf> (accessed March 30, 2015).

⁶⁴⁸ “Spanish Investigations into the United States Torture Program,” European Center for Constitutional and Human Rights, http://www.ecchr.eu/en/our_work/international-crimes-and-accountability/u-s-accountability/spain.html (accessed August 16, 2015).

⁶⁴⁹ Spanish courts also have jurisdiction where the defendant is a Spanish national. Permanent Mission of Spain to the United Nations, declaration pursuant to para. 3 of General Assembly Resolution 67/98 of 14 December 2012, “The scope and application of the principle of universal jurisdiction,” No. 094 FP, April 29, 2013, http://www.un.org/en/ga/sixth/68/UnivJur/Spain_E.pdf (accessed March 30, 2015).

⁶⁵⁰ The four former Guantanamo detainees had all been criminally charged in Spain but were acquitted at trial, at least in part due to the use of torture and other forms of serious abuse to which they had been subjected at Guantanamo. For more information, see CCR, “The Spanish Investigation into U.S. Torture,” undated, <http://ccrjustice.org/spain-us-torture-case> (accessed March 30, 2015); “Spanish Investigations into the United States Torture Program,” ECCHR, last modified June 25, 2013, <http://www.ecchr.de/spain-600.html> (accessed March 30, 2015).

⁶⁵¹ Central Court for Preliminary Criminal Proceedings Number Five, Madrid National Court, Case No. 150/2009, Decision (Preliminary Investigation), January 27, 2010, unofficial English translation, http://ccrjustice.org/files/National%20Court%20Madrid%20Decision%201.27.10_English_o.pdf (accessed March 30, 2015).

The public prosecutor appealed Garzón's decision to proceed with the investigation, but the Supreme Court's Criminal Chamber rejected the appeal.⁶⁵² In May 2010, the case was reassigned following Garzón's suspension from his judicial function for having tried to investigate Franco-era abuses.⁶⁵³

In January 2011, CCR and ECCHR, both of whom later joined the case as formal parties,⁶⁵⁴ requested that former Guantanamo commander Geoffrey Miller be subpoenaed to explain his role in the alleged torture of the detainees.⁶⁵⁵ A year later, with still no response from US or UK authorities, the new judge on the case issued a ruling reaffirming the court's jurisdiction over the case without deciding on the subpoena request.⁶⁵⁶

In March 2014, Spain's Parliament again amended its law to restrict jurisdiction following a diplomatic row with China.⁶⁵⁷ The new law introduced an extensive set of requirements related to the nationality of the suspect and victims and the suspect's status in the country, placing Spain in breach of its international legal obligations to extradite or prosecute certain offenses like torture and war crimes.⁶⁵⁸ Despite this change, the judge presiding over the *Guantanamo* case ruled, in April 2014, that the investigation should

⁶⁵² Spanish Supreme Court of Justice, Criminal Chamber, Case No. 66/2010, Decision, April 6, 2011, unofficial English translation, <http://ccrjustice.org/files/Resolution%20High%20Court-%2017%20May%202011%20-ENG.pdf> (accessed March 30, 2015).

⁶⁵³ Garzón faced criminal charges for investigating cases of illegal detention and enforced disappearances committed during the Spanish Civil War, despite Spain's 1977 amnesty law. For more information on the case, see "Spain: Garzón Trial Threatens Human Rights," Human Rights Watch news release, January 13, 2012, <http://www.hrw.org/news/2012/01/13/spain-garz-n-trial-threatens-human-rights>.

⁶⁵⁴ The court admitted CCR and ECCHR to represent two of the former detainees on January 10, 2013. Central Court for Preliminary Criminal Proceedings Number Five, Madrid National Court, Case No. 150/2009, Decision (Preliminary Investigation), January 10, 2013, unofficial English translation, <http://ccrjustice.org/files/2013-01-10%20Order%20re%20CCR%20and%20ECCHR.pdf> (accessed March 30, 2015).

⁶⁵⁵ Criminal Complaint by CCR and ECCHR against Geoffrey Miller, Central Court for Preliminary Criminal Proceedings Number Five, Madrid National Court, Case No. 150/2009, Criminal Complaint, January 4, 2011, unofficial English translation, <http://ccrjustice.org/files/FINAL%20Spanish%20Miller%20Submission.pdf> (accessed June 9, 2015).

⁶⁵⁶ Central Court for Preliminary Criminal Proceedings Number Five, Madrid National Court, Case No. 150/2009, Decision (Preliminary Investigation), January 13, 2012, unofficial English translation, [http://ccrjustice.org/files/2012-01-13%20AUTO%20GUANTANAMO%20\(Eng\).pdf](http://ccrjustice.org/files/2012-01-13%20AUTO%20GUANTANAMO%20(Eng).pdf) (accessed March 30, 2015).

⁶⁵⁷ Human Rights Watch, "UN Universal Periodic Review submission: Spain," May 2014, http://www.upr-info.org/sites/default/files/document/spain/session_21_-_january_2015/hrw_-_human_rights_watch.pdf; Jim Yardley, "Spain Seeks to Curb Law Allowing Judges to Pursue Cases Globally," *New York Times*, February 10, 2014, http://www.nytimes.com/2014/02/11/world/europe/spanish-legislators-seek-new-limits-on-universal-jurisdiction-law.html?_r=0 (accessed March 30, 2015).

⁶⁵⁸ Human Rights Watch, "UN Universal Periodic Review submission: Spain."

proceed in light of Spain's obligations under the Convention against Torture and the Geneva Conventions.⁶⁵⁹ Spain's National Court upheld this decision in November 2014.⁶⁶⁰

However, in May 2015, in a case against Chinese officials involving abuses in Tibet, Spain's Supreme Court issued a new decision interpreting in a more restrictive manner the legislative changes on universal jurisdiction.⁶⁶¹ Citing that ruling, on July 17, 2015, Spain's National Court dismissed the entire Guantanamo case.⁶⁶² The complainants have lodged an appeal against the decision.⁶⁶³

CIA Flight Investigations

Spanish authorities launched a civil investigation in November 2005 into claims that CIA planes carrying detainees had made secret stopovers on Spanish soil, but concluded that the flights were legal.⁶⁶⁴ Around the same time, a judge in Mallorca, where US planes are alleged to have landed, opened a criminal investigation. In light of the torture allegations, he deferred the case to the National Court. In June 2006, Judge Ismael Moreno of the National Court opened a criminal investigation targeting the 13 US officials who were on board the flight that rendered Khaled el-Masri, which allegedly stopped in Spain before continuing on to Macedonia to abduct el-Masri.⁶⁶⁵ A group of Spanish lawyers and other professionals from

⁶⁵⁹ Central Court for Preliminary Criminal Proceedings Number Five, Madrid National Court, Case No. 150/2009, Decision (Preliminary Investigations), April 15, 2014, unofficial English translation, http://ccrjustice.org/files/15April2014_No.5_Decision_Ordering_case_to_proceed_ENG.pdf (accessed March 30, 2015).

⁶⁶⁰ "El juez Ruz logra respaldo para investigar las torturas de Guantánamo," *El País*, November 13, 2014, http://politica.elpais.com/politica/2014/11/13/actualidad/1415882427_280141.html (accessed June 9, 2015).

⁶⁶¹ Spanish Supreme Court, 2nd Chamber in Criminal Matters, Ruling No. 296/2015, May 6, 2015, <http://supremo.vlex.es/vid/571092402> (accessed August 20, 2015).

⁶⁶² Central Court for Preliminary Criminal Proceedings Number Five, Madrid National Court, July 17, 2015, unofficial English translation, http://ccrjustice.org/sites/default/files/attach/2015/08/2015-07-17_UJSpain_NationalCourtDecision2_eng.pdf (accessed August 20, 2015).

⁶⁶³ "Former Detainees and Human Rights Groups Appeal Spain's Decision to Discontinue Guantánamo Investigation," *Center for Constitutional Rights*, July 23, 2015, <http://ccrjustice.org/home/press-center/press-releases/former-detainees-and-human-rights-groups-appeal-spain-s-decision> (accessed August 16, 2015).

⁶⁶⁴ "Spain probes 'secret CIA flights,'" *BBC News*, November 15, 2005, <http://news.bbc.co.uk/2/hi/europe/4439036.stm> (accessed June 3, 2015); "Spain court launches investigation into CIA rendition flights," *Jurist*, June 12, 2006, <http://jurist.org/paperchase/2006/06/spain-court-launches-investigation.php> (accessed June 3, 2015).

⁶⁶⁵ The opening of the investigation happened just days after a Council of Europe report named Spain as one of a number of countries through which CIA flights transited. "Spain court launches investigation into CIA rendition flights," *Jurist*; "Spain doesn't object to secret flights," *El País*, December 3, 2010, http://elpais.com/m/elpais/2010/12/03/inenglish/1291357242_850210.html (accessed June 3, 2015).

Mallorca and the APDHE are civil parties in the case.⁶⁶⁶ Later that year, media reports revealed that additional US planes had made stopovers elsewhere in Spain.⁶⁶⁷

The most challenging aspect of the case proved to be determining the identity of the US officials on the flight. A Spanish national police investigation identified a list of 13 suspects and, in May 2010, led to the issuance of arrest warrants for these individuals on charges of using false documents to enter the country.⁶⁶⁸ Judge Moreno continued his efforts to confirm the suspects' identities, including by sending judicial cooperation requests to German and UK authorities in October 2012.⁶⁶⁹

Judge Moreno later broadened the investigation to address whether four senior Spanish officials should also be held criminally responsible for authorizing US stopover flights in the country.⁶⁷⁰ In November 2013, despite opposition from civil parties, prosecutors requested dismissal of both investigations.⁶⁷¹ Judge Moreno dismissed the investigation into the Spanish officials, and stayed the investigation into the CIA officials in September 2014. An appeals court upheld his ruling in November 2014 on the grounds that the allegations against the Spanish officials were insufficient to establish that they knew that the CIA detainees were being abused, and that Spanish authorities had—at

⁶⁶⁶ "Spain doesn't object to secret flights," *El País*; APDHE, "Qué Hacemos," <http://www.apdhe.org/tras-la-reforma-de-la-justicia-universal-el-juzgado-central-de-instruccion-no-5-de-la-audiencia-nacional-decide-proseguir-con-la-investigacion-del-caso-de-genocidio-en-el-sahara-occidental-y-del-cas/>.

⁶⁶⁷ "Spain doesn't object to secret flights," *El País*.

⁶⁶⁸ Prosecutors, who had requested the issuance of arrest warrants, asserted that the UK-based NGO Reprieve was in possession of the names of the 13 CIA agents. Jeff Stein, "Spanish prosecutors want 13 CIA agents arrested," *Washington Post*, May 12, 2010, http://voices.washingtonpost.com/spy-talk/2010/05/spanish_prosecutors_want_13_ci.html (accessed June 8, 2015); "Spain doesn't object to secret flights," *El País*.

⁶⁶⁹ These officials included Miguel Nadal, then-Secretary of State for Foreign Affairs; Miguel Aguirre de Cárcer, then-Director General of Foreign Policy for North America in the Foreign Affairs Ministry; Javier Jiménez-Ugarte, former Secretary General for Defense Policy in the same ministry; and Ramón Gil-Casares, former cabinet director of foreign policy for the prime minister. The cooperation requests appear to have been directed at asking foreign judicial authorities to share information and interview persons who might know the identity of the US officials under investigation. US officials later described this collaboration between Spanish and German judicial authorities as particularly worrisome because it "complicate[s] our [US] efforts to manage this case at a discreet government-to-government level." Giles Tremlett, "Wikileaks: US pressured Spain over CIA rendition and Guantánamo torture," *The Guardian*, December 1, 2010.

⁶⁷⁰ José María Irujo, "Solicitada la imputación de cuatro españoles por los vuelos de la CIA," *El País*, November 6, 2013, http://politica.elpais.com/politica/2013/11/06/actualidad/1383747636_079062.html (accessed June 8, 2015).

⁶⁷¹ Prosecutors based their request on the grounds that the court had been unable to confirm the true identity of the 13 CIA agents. *Ibid.*

least for now—exhausted all leads and been unable to conclusively identify the CIA agents involved.⁶⁷² The civil parties have appealed the case to the Supreme Court.⁶⁷³

Switzerland

In February 2011, CCR and ECCHR prepared criminal complaints against former President Bush on behalf of two persons who had allegedly been tortured during their detention at Guantanamo Bay. However, the complaints were never filed as Bush cancelled his trip to Geneva.⁶⁷⁴

Canada

In September 2011, CCR and the Canadian Center for International Justice (CCI) called on the Canadian minister of justice and attorney general to open a criminal investigation against former President Bush for his alleged role in authorizing and overseeing the “administration’s well-documented torture program.”⁶⁷⁵ Bush was expected to go to Canada the following month to attend an economic summit.⁶⁷⁶ A week before Bush’s planned visit, the NGOs publicly expressed their intention to assist torture survivors in

⁶⁷² Spain Court of Appeals, Case No. 346/2014, Decision, November 17, 2014, <http://www.poderjudicial.es/search/doAction?action=contentpdf&database=AN&reference=7354188&links=%22336/2014%22&optimize=20150422&publicinterface=true> (accessed June 9, 2015). See also M.F., “El juez archiva la investigación de un vuelo de la CIA que hizo escala en Palma,” *El País*, September 8, 2014, http://politica.elpais.com/politica/2014/09/08/actualidad/1410185663_522922.html (accessed June 8, 2015); Fernando J. Pérez, “La Audiencia Nacional da carpetazo a la investigación de los vuelos de la CIA,” *El País*, January 12, 2015, http://politica.elpais.com/politica/2015/01/12/actualidad/1421074069_148757.html (accessed June 8, 2015).

⁶⁷³ Mateo Balin, “Los querellantes piden al Supremo reabrir la causa de los ‘vuelos de la CIA,’” *La Rioja*, February 20, 2015 <http://www.larioja.com/nacional/201502/20/querellantes-piden-supremo-reabrir-20150220005656-v.html> (accessed June 8, 2015).

⁶⁷⁴ Swiss law requires the presence of the suspect before a criminal investigation can be opened. Swiss Criminal Code of December 1937, art. 6, <http://www.admin.ch/ch/e/rs/3/311.o.en.pdf> (accessed March 30, 2015). Draft complaint against George W. Bush prepared by CCR and ECCHR, undated, <http://ccrjustice.org/files/FINAL%207%20Feb%20BUSH%20INDICTMENT.pdf> (accessed April 30, 2015). See also Ewen MacAskill, “George Bush calls off trip to Switzerland,” *The Guardian*, February 6, 2011, <http://www.theguardian.com/law/2011/feb/06/george-bush-trip-to-switzerland> (accessed April 30, 2015).

⁶⁷⁵ Letter from CCR and the Canadian Centre for International Justice (CCI) to Robert Douglas Nicholson, Minister of Justice and Attorney General of Canada, September 29, 2011, <http://ccrjustice.org/files/2011.09.29%20Cover%20Letter%20to%20Canadian%20Minister%20of%20Justice.pdf> (accessed March 30, 2015); Draft indictment against George W. Bush pursuant to the Canadian Criminal Code and the Convention against Torture, prepared by CCR and CCIJ, September 29, 2011, <http://ccrjustice.org/files/2011.09.29%20Bush%20Canada%20Indictment.pdf> (accessed March 30, 2015).

⁶⁷⁶ “Canada: Don’t Let Bush Get Away With Torture,” Human Rights Watch news release, October 12, 2011, <http://www.hrw.org/news/2011/10/12/canada-don-t-let-bush-get-away-torture>.

filing a formal criminal complaint if the minister failed to initiate an investigation.⁶⁷⁷ On October 20, 2011, the day of his expected arrival, CCIJ lodged a criminal complaint against Bush with the Surrey provisional court in British Columbia, where the summit was to be held.⁶⁷⁸ Within hours, the prosecutor stayed the proceedings.⁶⁷⁹ Bush attended the summit and no further steps were taken in the case.⁶⁸⁰

In April 2012, CCR and CCIJ reported the incident to the UN Committee against Torture.⁶⁸¹ The committee urged Canada to take steps to exercise universal jurisdiction over persons alleged to be responsible for torture but did not mention the Bush visit.⁶⁸²

In November 2012, the same two NGOs—acting on behalf of four persons alleged to have been victims of torture at US-run military facilities in Afghanistan and Guantanamo Bay—filed an individual complaint with the UN Committee against Torture, arguing that Canada had violated its international obligations by failing to arrest Bush.⁶⁸³ In response, Canada asserted that it had insufficient evidence in its possession at the time to justify charging Bush and that it did not expect to receive assistance from US authorities.⁶⁸⁴ Both parties have submitted additional responses to the committee. One was a letter from the NGOs alerting the committee to Bush’s planned visit to Toronto in

⁶⁷⁷ Letter from CCR and CCIJ to Robert Douglas Nicholson, Minister of Justice and Attorney General of Canada, October 14, 2011, <http://ccrjustice.org/files/CCR%20CCIJ%20Follow%20up%20Letter%20s.pdf> (accessed March 30, 2015).

⁶⁷⁸ In Canada, such a complaint is known as an “information.” See Submission by Mathew J. Eisenbrandt, Legal Director of CCIJ, October 20, 2011, <http://ccrjustice.org/files/2011-10-20%20Court%20Information%20AS%20FILED.pdf> (accessed March 30, 2015).

⁶⁷⁹ Court order of stay of proceedings, October 20, 2011, <http://ccrjustice.org/files/2011-10-20%20Court%20Stay%20of%20proceedings.pdf> (accessed March 30, 2015); Letter from Andrew MacDonald, Deputy Regional Crown Counsel, to Matthew Eisenbrandt, Legal Director of CCIJ, October 24, 2011, <http://ccrjustice.org/files/2011-10-24%20Letter%20from%20Attorney%20General%20Staying%20the%20Case.pdf> (accessed March 30, 2015).

⁶⁸⁰ “George W. Bush draws protesters at B.C. appearance,” *CBC News*, October 20, 2011, <http://www.cbc.ca/news/canada/british-columbia/george-w-bush-draws-protesters-at-b-c-appearance-1.1097491> (accessed August 19, 2015).

⁶⁸¹ CCR and CCIJ, “Submission of the Center for Constitutional Rights and the Canadian Centre for International Justice to the Committee against Torture on the Examination of the Sixth Periodic Report of Canada: The Case of George W. Bush and Canada’s Violation of Its Obligations under the *Convention Against Torture*,” undated, <http://ccrjustice.org/files/CCR-CCIJ%20CAT%20CANADA%20Report%20re%20Bush.pdf> (accessed March 30, 2015).

⁶⁸² UN Committee against Torture, “Consideration of reports submitted by States parties under article 19 of the Convention, Concluding observations of the Committee against Torture, Canada,” CAT/C/CAN/CO/6, June 25, 2012, <http://www2.ohchr.org/english/bodies/cat/docs/CAT.C.CAN.CO.6.doc> (accessed March 30, 2015).

⁶⁸³ *Hassan bin Attash, Sami el-Haji, Muhammed Khan Tumani and Murat Kurnaz v. Canada*, Complaint to the UN Committee against Torture, November 14, 2012, <http://ccrjustice.org/files/CAT%20Canada%20Petition%20.pdf> (accessed March 30, 2015).

⁶⁸⁴ Permanent Mission of Canada to the United Nations, Submission of Canada regarding the admissibility and merits of the communication to the UN Committee Against Torture, Communication No. 536/2013, October 7, 2013, <http://ccrjustice.org/files/Canada%20Response%20to%20CAT.pdf> (accessed April 30, 2015).

May 2014.⁶⁸⁵ However, no action was taken during Bush’s visit and the committee has not yet issued findings in the case.⁶⁸⁶

Investigations Focused on European Complicity

Poland

In March 2008, the district prosecutor’s office in Warsaw opened a criminal investigation into CIA-related abuses committed on Polish territory, although the scope of the investigation has never been disclosed.⁶⁸⁷ The investigation appears to be limited to Polish involvement.⁶⁸⁸ The investigation has languished for years, partly due to unexplained changes in staffing, the transfer of cases from Warsaw to another city, claims of inadequate cooperation from US authorities, and invocation of the “state secrets” doctrine.⁶⁸⁹ In September 2015 the Polish prosecutor announced that the US rejected four further requests for documents and information, including requests for statements from witnesses still in US custody in Guantanamo.⁶⁹⁰

Three men who are held at Guantanamo Bay—Abd al-Rahim al-Nashiri, Zayn al-Abidin Muhammed Husayn (Abu Zubaydah), and Walid bin Attash—have been granted formal

⁶⁸⁵ Letter from CCR and CCIJ to the UN Committee against Torture, May 8, 2014, <http://ccrjustice.org/files/FINAL%20submission%20to%20CAT%20Canada%20May%202014%20a.pdf> (accessed April 30, 2015).

⁶⁸⁶ CCIJ, “George W. Bush and the “War on Terror,” undated, <http://www.ccij.ca/cases/george-w-bush/> (accessed August 19, 2015).

⁶⁸⁷ In September 2012, the European Parliament “deplore[d] the lack of official communication on the scope, conduct and state of play of the investigation [and] call[ed] on the Polish authorities to conduct a rigorous inquiry with due transparency, allowing for the effective participation of victims and their lawyers.” European Parliament Resolution of 11 September 2012 on alleged transportation and illegal detention of prisoners in European countries: follow-up of the European Parliament TDIP Committee report, (2012/2033/ (INI)). See also European Parliament Resolution of 10 October 2013 on alleged transportation and illegal detention of prisoners in European countries by the CIA, (2013/2702 (RSP)); UN Joint Study on Secret Detention, para. 118; UN Human Rights Committee, “Concluding Observations of the Human Rights Committee: Poland,” U.N. Doc. CCPR/C/POL/CO/6/ (2010), October 27, 2010, available at <http://www1.umn.edu/humanrts/hrcommittee/poland2010.html> (accessed June 5, 2015).

⁶⁸⁸ The investigation appears to be aimed only at Polish officials’ potential involvement in CIA-related abuses. Christian Lowe and Pawel Sobczak, “After U.S. torture report, Poland asks what its leaders knew,” *Reuters*, December 12, 2014, <http://www.reuters.com/article/2014/12/12/us-usa-cia-torture-poland-insight-idUSKBN0JQ1QQ20141212> (accessed April 30, 2015).

⁶⁸⁹ Some have suggested that Polish authorities have prevented the investigation from moving forward. Amnesty International, “Breaking the Conspiracy of Silence,” p. 10; OSJI, “Globalizing Torture: CIA Secret Detention and Extraordinary Rendition,” pp. 99-102.

⁶⁹⁰ “US refuses more requests from Poland for assistance in CIA secret prisons probe,” *Associated Press*, September 22, 2015, <http://www.foxnews.com/us/2015/09/22/us-refuses-more-requests-from-poland-for-assistance-in-cia-secret-prisons-probe/> (accessed October 26, 2015).

victim status in the case.⁶⁹¹ Fellow Guantanamo detainee Mustafa al-Hawsawi also sought victim status but was turned down.⁶⁹² Bin Attash and al-Hawsawi currently face charges before a US military commission for their alleged involvement in planning the September 11, 2001 attacks, and al-Nashiri faces charges for his alleged involvement in planning an attack against the *USS Cole*—a US Navy warship docked in a Yemen harbor in October 2000. Abu Zubaydah does not face any charges.

In March 2012, a confidential source reported to the media that former Polish intelligence chief Zbigniew Siemiątkowski had been charged in the case. Siemiątkowski acknowledged being questioned, but the prosecutor’s office refused to confirm whether he faces charges.⁶⁹³ In early February 2013, the Polish minister of justice made a statement suggesting that the decision to charge Siemiątkowski had been made “hastily,” adding that the case “needs [to] be addressed with extreme restraint.”⁶⁹⁴ After human rights groups expressed concern over the statement—in particular whether it revealed a lack of prosecutorial independence—the prosecutor general stated that there had been “no official confirmation that they [prosecutors] had charged anybody.”⁶⁹⁵ Less than two weeks later, a Polish newspaper reported that the charges against Siemiątkowski would soon be dropped.⁶⁹⁶ The prosecutor’s office confirmed that an investigation was underway but would not indicate whether it was looking into Siemiątkowski’s role.⁶⁹⁷

⁶⁹¹ According to an interview that Janusz Śliwa, deputy prosecutor in Krakow, gave Amnesty International, the granting of “injured person,” or victim, status in criminal proceedings means that there is a “likelihood” that a person has suffered a crime in Poland. Amnesty International, *Unlock the Truth: Poland’s Involvement in CIA Secret Detention*, June 2013, http://www.amnesty.org.uk/sites/default/files/2013_unlock_the_truth_-_polands_involvement_in_cia_secret_detention.pdf (accessed April 30, 2015), p. 16.

⁶⁹² The prosecutor rejected the application for victim status in March 2014. Al-Hawsawi appealed the decision, but the prosecutor again declined the request in December 2014. Amnesty International, “Breaking the Conspiracy of Silence,” p 10. The Redress website says Polish law prevents them from disclosing the grounds for the decision. See Redress, “Mustafa al-Hawsawi,” undated, <http://www.redress.org/case-docket/al-hawsawi-case-1>.

⁶⁹³ Amnesty International, *Unlock the Truth*, p. 16.

⁶⁹⁴ *Ibid.*, pp. 17-18; Interview with Jarosław Gowin (“Rozmowa dnia: Jarosław Gowin”), Polish Radio 1 (“Polskie Radio”), February 5, 2013 (accessed April 29, 2015).

⁶⁹⁵ Amnesty International, *Unlock the Truth*, p. 18; Ewe Siedlecka, “Seremet: Let’s not confuse life with film” (“Seremet: Nie mylmy życia z filmem”), *Gazeta Wyborcza*, April 28, 2013, http://wyborcza.pl/1,76498,13812229,Seremet__Nie_mylmy_zycia_z_filmem.html#ixzz2RqYAF4Do (accessed April 29, 2015).

⁶⁹⁶ Amnesty International, *Unlock the Truth*, p. 18; “Polish Prosecutors to Drop Charges in CIA Jail Inquiry-Report,” *Reuters*, February 19, 2013, <http://www.reuters.com/article/2013/02/19/us-poland-cia-siematkowski-idUSBRE910MT20130219> (accessed April 29, 2015).

⁶⁹⁷ “Polish Prosecutors to Drop Charges in CIA Jail Inquiry-Report,” *Reuters*.

Al-Nashiri and Abu Zubaydah have both brought Poland before the ECtHR for its failure to investigate the abuses committed against them during their time in US custody. In July 2014, the ECtHR ruled that Poland had authorized a CIA black site to be used on its soil and that Polish authorities bore responsibility for the two men's torture and unlawful rendition.⁶⁹⁸ It found that Polish authorities had failed to properly investigate the abuses despite national authorities' assertions that their 2008 investigation remained ongoing. The court ordered Poland to pay Abu Zubaydah and al-Nashiri €100,000 (about \$112,000) in damages.⁶⁹⁹ Poland sought to appeal the decision, but its request was denied.⁷⁰⁰

Following the release of the Senate Summary in December 2014, Polish prosecutors announced that they would request the full version of the committee's study for their investigation.⁷⁰¹ They appear to have done so, but in June 2015 Polish judicial authorities said that the US was refusing to comply with the request.⁷⁰²

Lithuania

In January 2010, following a parliamentary investigation that confirmed the existence of two black sites and that Lithuanian airports and airspace had been used for CIA-related flights, the prosecutor general's office opened a criminal investigation.⁷⁰³ One year later,

⁶⁹⁸ "Poland: Landmark Rulings on CIA Torture Complicity," Human Rights Watch news release, July 24, 2014, <https://www.hrw.org/news/2014/07/24/poland-landmark-rulings-cia-torture-complicity>. Both men continue to be held by US authorities at Guantanamo Bay. Human Rights Watch was the first to present evidence identifying locations in Poland and Romania as CIA black sites. "Human Rights Watch Statement on U.S. Secret Detention Facilities in Europe," Human Rights Watch news release, November 6, 2005, <https://www.hrw.org/news/2005/11/06/human-rights-watch-statement-us-secret-detention-facilities-europe>.

⁶⁹⁹ The court also awarded Abu Zubaydah €30,000 euros (about \$34,000) in costs and expenses. European Court of Human Rights, *Al-Nashiri v. Poland*, (28761/11), Judgment of 24 July 2014, available at <http://hudoc.echr.coe.int/webservices/content/pdf/003-4832205-5894802> (accessed April 29, 2015); European Court of Human Rights, *Husayn (Abu Zubaydah) v. Poland*, (7511/13), Judgment of 24 July 2014, available at <http://hudoc.echr.coe.int/sites/eng/pages/search.aspx?i=001-146047> (accessed April 29, 2015).

⁷⁰⁰ Nikolaj Nielsen, "European Court Confirms Polish Complicity in CIA Rendition," *EU Observer*, February 18, 2015, <https://euobserver.com/justice/127697> (accessed April 29, 2015).

⁷⁰¹ "After U.S. torture report, Poland asks what its leaders knew," *Reuters*, December 12, 2014.

⁷⁰² Christian Lowe and Wojciech Zurawski, "Poland says Washington stonewalling CIA jail investigation," *Reuters*, June 12, 2015, <http://www.reuters.com/article/2015/06/12/us-usa-cia-torture-poland-idUSKBN0S1N220150612> (accessed June 13, 2015).

⁷⁰³ Lithuanian authorities claimed that they had been unable to determine whether the site was used to hold prisoners due to lack of cooperation from US authorities. "Lithuania asks U.S. to say if CIA Tortured Prisoners There," *Reuters*, December 10, 2014, http://www.huffingtonpost.com/2014/12/10/lithuania-cia-torture_n_6300540.html (accessed April 30, 2015); OSJI, "Globalizing Torture: CIA Secret Detention and Extraordinary Rendition," pp. 90-93; "Lithuania: Reopen Investigation Into Secret CIA Prisons," Human Rights Watch news release, June 25, 2013, <https://www.hrw.org/news/2013/06/25/lithuania-reopen-investigation-secret-cia-prisons>.

the case was abruptly closed for lack of evidence.⁷⁰⁴ Prior to its discontinuance, Amnesty International and Reprieve had brought information to the attention of the prosecutor's office, including allegations that Abu Zubaydah had been held in one of the country's black sites and tortured.⁷⁰⁵ Abu Zubaydah then filed an application against Lithuania before the ECtHR in July 2011.⁷⁰⁶ The case is pending, and the European Parliament has since called on Lithuania to reopen its investigation in light of new evidence.⁷⁰⁷

In September 2013, a new complaint was filed by Redress and the Human Rights Monitoring Institute (HRMI) on behalf of another former CIA detainee, Mustafa al-Hawsawi, alleging that he too had been held and tortured by the CIA at a black site in the country.⁷⁰⁸ In October 2013, the prosecutor's office decided not to open an investigation. Redress and HRMI appealed this decision, and they secured a favorable decision by the Vilnius Regional Court in January 2014 that affirmed al-Hawsawi's right to an investigation of his claims. In February 2014, the prosecutor general's office opened a formal investigation.⁷⁰⁹

Following the release of the Senate Summary in December 2014, the prosecutor general's office claims to have sent a formal request for legal assistance to US authorities.⁷¹⁰ In April

⁷⁰⁴ The prosecutor general's office said some materials gathered during the investigation constituted a state secret and could not be used for prosecution purposes. Amnesty International Submission to the UN Universal Periodic Review, "Lithuania: Homophobic Legislation and Accountability for Complicity in US-led rendition and secret detention programs," October 2011, <https://www.amnesty.org/download/Documents/32000/eur530012011en.pdf> (accessed April 30, 2015), pp. 5-7.

⁷⁰⁵ *Ibid.*, pp. 6-7.

⁷⁰⁶ European Court of Human Rights, *Abu Zubaydah v. Lithuania*, (45454/11), Judgment of 14 July 2011, <http://hudoc.echr.coe.int/sites/eng/pages/search.aspx?i=001-115816> (accessed April 30, 2015).

⁷⁰⁷ European Parliament Resolution of 11 September 2012 on alleged transportation and illegal detention of prisoners in European countries; European Parliament Resolution of 10 October 2013 on alleged transportation and illegal detention of prisoners in European countries by the CIA; "Lithuania: Reopen Investigation Into Secret CIA Prisons," Human Rights Watch news release.

⁷⁰⁸ Letter from Carla Ferstman, Director of Redress, and Natalija Bitiukova, Deputy Director of the Human Rights Monitoring Institute (HRMI) to Lithuanian Prosecutor General Darius Valys, "Request for an investigation concerning suspicion of criminal offences committed in Lithuania against Mr Mustafa al-Hawsawi," September 13, 2013, <http://www.redress.org/downloads/casework/final-lithuania---investigation-request.pdf> (accessed June 4, 2015).

⁷⁰⁹ "Prosecutor Launches New Investigation into Lithuania CIA Rendition Claims," Redress press release, February 20, 2014, <http://www.redress.org/downloads/lithuania-investigation-press-release---final.pdf> (accessed April 30, 2015); "Lithuania Opens CIA Rendition Investigation," Amnesty International public statement, February 21, 2014, http://www.amnesty.eu/content/assets/Reports/21022014_Lithuania_CIA_rendition_investigation_public_statement.pdf (accessed April 30, 2015). For more information on the case, see Redress, "Mustafa al-Hawsawi," undated, <http://www.redress.org/case-docket/al-hawsawi-case-1> (accessed June 1, 2015).

⁷¹⁰ The prosecutor's office declined to comment on the specific contents of the request. "Lithuania Parliament Urged to Once Again Probe CIA Prison," *Baltic News Service*, December 29, 2014, <http://en.delfi.lt/lithuania/foreign-affairs/lithuanian-parliament-urged-to-once-again-probe-into-cia-prison.d?id=66776060> (accessed April 30, 2015). See also Amnesty International, "Breaking the Conspiracy of Silence: USA's European 'Partners in Crime' Must Act After Senate Torture Report," January 2015, <https://www.amnesty.org/download/Documents/212000/euro10022015en.pdf> (accessed April 30, 2015), pp. 17-18.

2015, it announced the reopening of its initial investigation and included al-Hawsawi's claim in the investigation.⁷¹¹ The investigation remains ongoing at the time of writing.

Romania

Successive Romanian governments have denied hosting a secret prison.⁷¹² In May 2012, the Open Society Justice Initiative (OSJI) filed a criminal complaint with the Romanian general prosecutor on behalf of Abd al-Rahim al-Nashiri, alleging that he had been held at a black site within the country and tortured there.⁷¹³ The general prosecutor acknowledged the complaint, assigned it a case number, and said he would review it, but nothing has since happened.⁷¹⁴ OSJI subsequently lodged an application against Romania before the ECtHR.⁷¹⁵ The case is pending.

After the release of the Senate Summary, former Romanian president Ion Iliescu and former intelligence chief Ioan Talpes admitted that Romania did in fact host the site.⁷¹⁶ The current government claims to have no knowledge of the secret prison, but in December 2014 a ministry of justice official said that there was an ongoing judicial investigation in Romania into the allegations.⁷¹⁷ It is unclear whether this is the same case initiated by OSJI.

⁷¹¹ "Lithuanian Prosecutors Restart Investigation into Secret CIA Jail," *Reuters*, April 2, 2015, <http://rt.com/news/246365-lithuania-restart-probe-cia/> (accessed April 30, 2015); "Lithuania Reopens CIA 'Black Site' Investigation," *Agence France Presse*, April 3, 2015, <http://www.globalpost.com/article/6505193/2015/04/02/lithuania-reopens-cia-black-site-investigation> (accessed August 18, 2015).

⁷¹² In 2008, a superficial parliamentary inquiry concluded that no CIA detention centers had existed in Romania and that no US flights had transited through the country. OSJI, "Globalizing Torture: CIA Secret Detention and Extraordinary Rendition," pp. 103-06; Amnesty International, "Breaking the Conspiracy of Silence," p. 13.

⁷¹³ OSJI, "Litigation: Al-Nashiri v. Romania," updated August 6, 2012, <http://www.opensocietyfoundations.org/litigation/al-nashiri-v-romania> (accessed June 4, 2015).

⁷¹⁴ OSJI, "Globalizing Torture: CIA Secret Detention and Extraordinary Rendition," p. 106.

⁷¹⁵ European Court of Human Rights, *Adb al-Rahim Husseyn Muhammad al-Nashiri v. Romania*, (33234/12), Judgment of June 1, 2012, available at <http://hudoc.echr.coe.int/sites/fra/pages/search.aspx?i=001-113814> (accessed June 4, 2015).

⁷¹⁶ "Former Romania president admits allowing CIA site," *Al Jazeera*, April 27, 2015, <http://www.aljazeera.com/news/2015/04/romania-president-admits-allowing-cia-site-150427140351035.html> (accessed August 18, 2015); "Romanian ex-spy chief acknowledges CIA had 'black prisons' in country," *The Guardian*, December 14, 2014, <http://www.theguardian.com/world/2014/dec/14/romania-cia-black-prisons-ioan-talpes> (accessed August 18, 2015).

⁷¹⁷ "U.S. torture report puts Romania's role under scrutiny," *Reuters*, December 16, 2014, <http://www.aol.com/article/2014/12/16/u-s-torture-report-puts-romanas-role-under-scrutiny/21117326/> (accessed August 18, 2015).

Macedonia

Despite strong evidence to the contrary, Macedonian authorities long denied any involvement in the rendition of Khaled el-Masri. In October 2008, el-Masri filed a formal request for a criminal investigation with the Skopje prosecutor's office. The prosecutor took no steps in the case before the statute of limitations for the crimes expired.⁷¹⁸ In September 2009, el-Masri then filed an application against Macedonia before the ECtHR. On December 12, 2012, the ECtHR found in favor of el-Masri. The court found that he had been subjected to torture and ill-treatment both within Macedonia and after his transfer to US authorities, and held Macedonia responsible for its role.⁷¹⁹

United Kingdom

In addition to a shelved public inquiry into allegations of UK complicity in the CIA torture program⁷²⁰ and the settlement of several civil claims for damages,⁷²¹ UK police and prosecutors have opened three criminal investigations, one of which remains open, and established a joint panel to examine possible criminal cases, the status of which is unclear.

British Criminal Investigations

The UK government opened the first investigation, known as "Operation Hinton," in November 2008, which focused on the alleged involvement of UK Security Service (MI5)

⁷¹⁸ OSJI, "Globalizing Torture: CIA Secret Detention and Extraordinary Rendition," pp. 94-95.

⁷¹⁹ European Court of Human Rights, *El-Masri v. The Former Yugoslav Republic of Macedonia*, pp. 58-60.

⁷²⁰ The Intelligence and Security Committee (ISC) conducted a first flawed investigation in 2007 which concluded that the UK has no involvement in rendition or torture, an outcome criticized by the UK Parliamentary Joint Human Rights Committee. The prime minister announced the launch of a judge-led inquiry in July 2010, but the inquiry was ultimately boycotted by civil society groups, including Human Rights Watch, over its weak powers and lack of independence. It was shelved by the government in January 2012 citing ongoing investigations but a second inquiry was promised. The Detainee Inquiry completed its preliminary report in June 2012 but the UK government did not publish it until December 2013. Government of the United Kingdom, "The Report of the Detainee Inquiry," December 2013, http://www.detaineeinquiry.org.uk/wp-content/uploads/2013/12/35100_Trafalgar-Text-accessible.pdf (accessed June 4, 2015). That same month, the UK government announced the ISC would take over responsibility for the investigation rather than establishing an independent inquiry as it had promised. The ISC commenced its investigation in September 2014, which is ongoing. See "UK: Broken Promise on UK Torture Inquiry," Human Rights Watch news release, December 21, 2013, <http://www.hrw.org/news/2013/12/21/uk-broken-promise-torture-inquiry> (accessed August 18, 2015); Amnesty International, "Breaking the Conspiracy of Silence," pp. 19-20.

⁷²¹ OSJI, "Investigations into CIA Renditions," November 2013, <http://www.opensocietyfoundations.org/factsheets/investigations-cia-renditions> (accessed June 4, 2015); OSJI, "Globalizing Torture: CIA Secret Detention and Extraordinary Rendition," pp. 115-16.

officers in the rendition and torture of Binyam Mohamed by US authorities.⁷²² The Crown Prosecution Service concluded that UK officials had involvement in his case but that there was “insufficient evidence” to bring criminal charges. The second investigation, known as “Operation Iden” and opened in June 2009, looked into the actions of UK Secret Intelligence Service (MI6) officers who interrogated suspects at the US-run prison in Bagram, Afghanistan. It too was closed for “insufficient evidence.”⁷²³

In January 2012, a third criminal investigation—which has become known as “Operation Lydd”—was opened to look into allegations that UK security service officers from MI5 or MI6 were involved in the unlawful rendition and torture of former Libyan opposition figures Abdullah al-Sadiq (known as Abdul Hakim Belhadj) and Sami Mostefa al-Saadi.⁷²⁴ Both men had filed complaints in November 2011 after the release of classified documents uncovered by Human Rights Watch in Libya that exposed UK officials’ role in their rendition.⁷²⁵ The investigation appears to be moving forward, with the police having handed prosecutors a file of evidence in October 2014.⁷²⁶ Also in January 2012, police and prosecutors announced the establishment of a joint panel to examine other allegations of UK complicity in US rendition and torture.⁷²⁷ The status of the joint panel and any other potential investigations beyond the Libya case is unclear.⁷²⁸

⁷²² OSJI, “Globalizing Torture: CIA Secret Detention and Extraordinary Rendition,” p. 116.

⁷²³ *Ibid.*, pp. 116-117.

⁷²⁴ “UK: Broken Promise on UK Torture Inquiry,” Human Rights Watch news release; OSJI, “Globalizing Torture: CIA Secret Detention and Extraordinary Rendition,” p. 117.

⁷²⁵ Human Rights Watch, *Delivered into Enemy Hands: US-Led Abuse and Rendition of Opponents to Gaddafi’s Libya*, September 6, 2012, http://www.hrw.org/sites/default/files/reports/libya0912webwcover_1.pdf, pp. 97-99, 104-06. Both men, along with Belhadj’s wife who was also rendered to Libya, have pursued civil claims. Belhadj and his wife’s claims are still ongoing. Amnesty International, “Breaking the Conspiracy of Silence,” pp. 20-21; Redress, “Belhaj v Jack Straw, former Head of Counter-Terrorism at MI6, Sir Mark Allen, the Secret Intelligence Service (MI6) and the Security Service (MI5),” undated, <http://www.redress.org/case-docket/belhadj-v-jack-straw-and-others> (accessed June 4, 2015). The UK government paid al-Saadi £2.23 million to settle his lawsuit. OSJI, “Globalizing Torture: CIA Secret Detention and Extraordinary Rendition,” p. 117.

⁷²⁶ Owen Bowcott and Richard Norton-Taylor, “Police hand Libyan abduction evidence to Crown Prosecution Service,” *The Guardian*, October 31, 2014, <http://www.theguardian.com/uk-news/2014/oct/31/met-libya-abduction-rendition-cps> (accessed June 4, 2015).

⁷²⁷ Ian Cobain, “Police to investigate MI6 over rendition and torture of Libyans,” *The Guardian*, January 12, 2012, <http://www.theguardian.com/world/2012/jan/12/libya-rendition-torture-abduction-mi6> (accessed June 4, 2015).⁷²⁸ Ian Cobain, “MI6 to be investigated over treatment of three more terror suspects,” *The Guardian*, April 23, 2013, <http://www.theguardian.com/world/2013/apr/23/mi6-al-qaida-investigation> (accessed October 26, 2015).

⁷²⁸ Ian Cobain, “MI6 to be investigated over treatment of three more terror suspects,” *The Guardian*, April 23, 2013, <http://www.theguardian.com/world/2013/apr/23/mi6-al-qaida-investigation> (accessed October 26, 2015).

Scottish Criminal Investigation

In May 2013, an online database⁷²⁹ mapping CIA renditions worldwide revealed that airports in Scotland were used to refuel CIA planes used in renditions.⁷³⁰ These revelations prompted Scottish police to open a criminal investigation, which was pending at writing.⁷³¹ The release of the Senate Summary brought renewed attention to the investigation and led Scottish police to request access to the full, un-redacted version of the report.⁷³²

Portugal

Information handed over by European parliamentarian Ana Gomes prompted Portugal's general prosecutor's office to launch a criminal investigation in February 2007 into US stopover flights that allegedly carried CIA rendition victims.⁷³³ Prosecutors closed the investigation in May 2009 due to lack of evidence. Gomes tried to appeal the decision on the grounds that the investigation had been inadequate and had not included all relevant testimony, but the prosecutor's office denied the request in September 2009.⁷³⁴

Potential Investigation by the International Criminal Court

In addition to the cases before national jurisdictions in Europe, the International Criminal Court (ICC) may be another potential forum for holding US officials accountable for post-9/11 abuses. In late 2014, the ICC prosecutor said that her office is considering whether to pursue an investigation into torture and other serious abuses allegedly committed by US armed forces in Afghanistan between 2003 and 2008.

⁷²⁹ The Rendition Project, "Rendition Flights," undated, <http://www.therenditionproject.org.uk/flights/index.html> (accessed June 10, 2015).

⁷³⁰ It does not appear that detainees were on board those aircrafts but rather that the aircrafts were refueling on their way to and from rendition operations in other countries. Billy Briggs, "Scottish Police Investigating British Role in CIA Kidnapping, Torture," *MintPress News*, June 2, 2015, <http://www.mintpressnews.com/scottish-police-investigating-british-role-in-cia-kidnapping-torture/206099/> (accessed June 4, 2015); Ian Cobain and James Ball, "New light shed on US government's extraordinary rendition program," *The Guardian*, May 22, 2013, <http://www.theguardian.com/world/2013/may/22/us-extraordinary-rendition-programme> (accessed June 4, 2015).

⁷³¹ Craig McDonald, "Revealed: Police investigate evidence that six CIA torture flights landed in Scotland," *Daily Record*, June 22, 2014, <http://www.dailyrecord.co.uk/news/scottish-news/revealed-police-investigate-evidence-six-3741550> (accessed June 5, 2015).

⁷³² If the request is granted, the full version of the report could reveal significant new information that was withheld at the request of UK officials. Billy Briggs, "Scottish Police Investigating British Role in CIA Kidnapping, Torture"; Craig McDonald, "Rendition experts fear police were too quick to clear CIA torture flights landing in Scotland," *Daily Record*, April 19, 2015, <http://www.dailyrecord.co.uk/news/scottish-news/rendition-expert-fears-police-were-5546817> (accessed June 5, 2015).

⁷³³ "Portugal Probes Alleged CIA Flights," *Washington Post*, February 5, 2007, <http://www.washingtonpost.com/wp-dyn/content/article/2007/02/05/AR2007020501454.html> (accessed June 5, 2015).

⁷³⁴ OSJI, "Globalizing Torture: CIA Secret Detention and Extraordinary Rendition," p. 103.

This announcement came in the context of the preliminary examination into Afghanistan that the ICC prosecutor initiated in 2007.⁷³⁵ Her jurisdiction is limited to war crimes, crimes against humanity, and genocide committed within the country or by Afghan nationals from May 1, 2003 onwards.⁷³⁶ The main focus of the examination appears to be crimes committed by pro- and anti-government forces, including the Taliban, the national intelligence service, the police, and the army. However, the prosecutor is also looking at “alleged abuse of detainees committed by international forces.”⁷³⁷

In December 2014, just before the Senate Summary was released, a report on the ICC prosecutor’s investigative activities singled out US officials as potential targets: “In particular, the alleged torture or ill-treatment of conflict-related detainees by US armed forces in Afghanistan in the period 2003-2008 forms another potential case identified by the Office.”⁷³⁸ The report says her office is looking at whether the “enhanced interrogation techniques” meet the threshold of gravity to fall within her jurisdiction and the “relevance and genuineness” of any steps to investigate and prosecute the alleged offenses by US authorities.⁷³⁹ During a media interview in March 2015, the prosecutor said, “We’re looking at the [US Senate] report very, very closely. And we will determine what to do, especially if it relates to our jurisdiction in Afghanistan.”⁷⁴⁰

While the US has not ratified the Rome Statute and is not a party to the ICC, the court would still have jurisdiction over US nationals with respect to crimes committed in Afghanistan since Afghanistan has ratified the treaty and the abuses took place on Afghan

⁷³⁵ The ICC has also opened a preliminary examination into alleged war crimes committed by officials of the United Kingdom, which is an ICC state party, involved in detainee abuse in Iraq. Since Iraq is not a party to the ICC, the ICC’s authority only reaches to nationals of ICC members who are implicated in crimes committed in Iraq, and not to any national implicated in crimes committed on Iraq’s territory, as is the case with Afghanistan. For more information on the preliminary examination, see Office of the Prosecutor, International Criminal Court, “Prosecutor of the International Criminal Court, Fatou Bensouda, re-opens the preliminary examination of the situation in Iraq,” May 13, 2014, http://www.icc-cpi.int/en_menus/icc/press%20and%20media/press%20releases/Pages/otp-statement-iraq-13-05-2014.aspx (accessed November 16, 2015).

⁷³⁶ Afghanistan ratified the Rome Statute on February 10, 2003. Office of the Prosecutor, International Criminal Court, “Report on Preliminary Examination Activities 2014,” December 2, 2014, <http://www.icc-cpi.int/iccdocs/otp/otp-pre-exam-2014.pdf> (accessed March 30, 2015), paras. 75-76.

⁷³⁷ *Ibid.*, para. 94.

⁷³⁸ *Ibid.*

⁷³⁹ *Ibid.*, paras. 95-96.

⁷⁴⁰ James Reinl, “Int’l Criminal Court Studying CIA Report ‘Very, Very Closely,’” *Reader Supported News*, March 6, 2015, <http://readersupportednews.org/news-section2/318-66/28925-intl-criminal-court-studying-cia-torture-report-very-very-closely> (accessed March 26, 2015).

soil. If the prosecutor finds that the crimes rise to the level of war crimes and that US prosecutorial authorities are not adequately investigating the alleged offenses, she could open a formal investigation.

The ICC should continue efforts to monitor whether US authorities are pursuing meaningful and effective criminal investigations and trials into detainee abuse allegedly committed by members of the US armed forces in Afghanistan between 2003 and 2008. If US authorities fail to pursue accountability for abuses and the alleged crimes meet the other criteria necessary for the ICC prosecutor to exercise jurisdiction in Afghanistan, her office should consider opening a formal investigation into US-related abuses as part of a broader investigation into crimes committed in Afghanistan.

Recommendations

To the US President

- Support the Attorney General's appointment of a special prosecutor to conduct a thorough, independent, and credible criminal investigation into the CIA rendition, detention, and interrogation program that examines the conduct of those who authorized and implemented torture and other abuse by the CIA, including conduct that may have purportedly been authorized.
- Acknowledge wrongdoing and formally apologize to victims of torture conducted or authorized by the US. In the absence of congressional action, establish an independent body to administer claims and provide appropriate redress, including compensation and rehabilitation.
- Declassify the full Senate Intelligence Committee Report on the CIA's detention and interrogation program, redacting only what is strictly necessary to protect national security. Improve declassification procedures more generally to ensure that only truly sensitive sources and methods remain classified and that the declassification process proceeds more quickly.
- Declassify entirely the CIA rendition, detention, and interrogation program rather than selective aspects or elements of it as is the current practice.
- Support legislative initiatives to require all US government agencies, including the CIA, to use only interrogation techniques listed in the Army Field Manual on Intelligence Interrogations.
- Instruct all relevant government agencies to initiate a review of their role in the CIA program as described in the full Senate Intelligence Committee report to identify mistakes made, lessons learned, and best practices going forward.
- Institute reforms at the CIA that provide more open congressional hearings on CIA policy and practice, stronger CIA reporting requirements to Congress, greater oversight from other divisions of the executive branch, and a bolstered CIA Office of the Inspector General.

To the Department of Justice

- The Attorney General should appoint a special prosecutor to conduct a thorough, independent, and credible criminal investigation and bring charges where warranted concerning CIA torture and other crimes. The investigation should look into the conduct of those who authorized and implemented the CIA program as well as those who went beyond what was authorized. In conducting such an investigation, ensure all relevant witnesses, including victims of the alleged torture and ill-treatment, are interviewed and all relevant physical evidence is collected and examined.
- Do not invoke the state secrets privilege in civil litigation concerning US torture except when absolutely necessary to prevent genuine harm to US national security and, even then, apply the privilege as narrowly as possible. Use of the privilege should not prevent the provision of appropriate redress to victims of US torture.

To the US Congress

- Enact legislation that would acknowledge wrongdoing, apologize, and provide redress, including compensation and rehabilitation, to victims of US torture and other abuse.
- Enact legislation that would prohibit the CIA from holding individuals in detention except immediately after a lawful arrest and ensuring their prompt transfer to an authorized detention authority.
- Revise Appendix M to the US Army Field Manual on Intelligence Interrogations to prohibit the use of abusive sleep and sensory deprivation techniques.

To Countries that Provided Support to the CIA Rendition Program

- Ensure impartial and independent criminal investigations of complicity in torture and other criminal offenses allegedly committed in the country by national or US officials in connection with CIA renditions or interrogations, and prosecute those implicated in crimes.
- Request a minimally redacted copy of the full Senate Intelligence Committee Report from the US government and provide it to prosecutorial authorities.

- Inform the US government that country officials do not object to the country or its nationals being named or identified in any information released to the public related to the CIA's rendition, detention, and interrogation program.
- Press US authorities to initiate meaningful criminal investigations in the United States and prosecute those responsible for torture and other serious abuses since 9/11.

To All Foreign Governments

- Exercise jurisdiction, including universal jurisdiction, as provided under domestic and international law, to investigate and, evidence permitting, prosecute US officials alleged to have been involved in criminal offenses against detainees in violation of international law.
- When permitted under domestic law, gather evidence to facilitate future prosecution of US officials should such officials enter their territory.
- Take measures to ensure that all relevant national agencies, including immigration, police, and prosecutorial authorities, are able to monitor, investigate, and prosecute US officials and others implicated in CIA torture should they enter the country.
- Call for a side meeting of the European Network of Contact Points in respect of persons responsible for genocide, crimes against humanity, and war crimes (known as the EU Genocide Network) to discuss investigations of torture and other abuses by US officials since 9/11.

To Specific National Authorities in the Following Countries

France

- Enforce the appellate court decision to issue a summons for former Guantanamo commander Gen. Geoffrey Miller and take all necessary steps to seek his appearance for questioning before French judicial authorities in connection with the ongoing investigation.

Germany

- Federal prosecutors should open a “structural investigation” to gather all evidence of US-related abuses committed post-9/11 that is available within the country and that may be used in future criminal proceedings in Germany or elsewhere.

- Request the extradition of the 13 CIA agents against whom arrest warrants have been issued in connection with the rendition of Khaled el-Masri.

Italy

- Judicial authorities should pursue legal avenues that would allow its European Arrest Warrants for the 26 US nationals convicted *in absentia* in connection with the rendition of Hassan Mustafa Osama Nasr (Abu Omar) to remain valid;
- The Ministry of Justice should pursue the extradition of all 26 Americans and afford them a retrial if they are extradited.

Lithuania, Macedonia, Poland, and Romania

- Prosecutors should conduct impartial and independent criminal investigations of complicity in torture and other criminal offenses allegedly committed in their countries by national and US officials in connection with CIA renditions or interrogations, and prosecute those implicated in crimes. Such investigations should include national and US government officials.

Portugal

- Prosecutors should reopen criminal investigations in connection with CIA torture in light of the Senate Summary.

Spain

- Judicial authorities should reopen the criminal investigation in the “Bush Six” case because the US Department of Justice has taken no further steps to investigate and prosecute those alleged to be responsible for abuse of detainees at Guantanamo.
- Judicial authorities should ensure that the second criminal investigation into alleged abuse of detainees at Guantanamo proceeds based on the Spanish nationality of one of the victims.

United Kingdom

- Prosecutors should conduct impartial and independent criminal investigations of complicity in torture and other criminal offenses allegedly committed in the country

by national and US officials in connection with CIA renditions or interrogations, and prosecute those implicated in crimes.

- Scottish police should expand their ongoing criminal investigation into CIA rendition flights to include US officials.

To the European Parliament, the Parliamentary Assembly of the Council of Europe, and UN Experts and Bodies

- Monitor the implementation of recommendations made in prior reports to countries identified as having supported the CIA rendition, detention, and interrogation program.
- Continue to call on countries that supported the CIA program to investigate and prosecute all those responsible for CIA torture and other abuses in their country, including national and US officials.
- Encourage police and judicial authorities in different countries to strengthen cooperation with respect to ongoing or future investigations and prosecutions of CIA torture and other offenses.
- Call on the European Genocide Network to convene a side meeting to discuss investigations of torture and other abuses by US officials since 9/11.
- Press US authorities to initiate meaningful criminal investigations and prosecute those responsible for torture and other serious abuses committed since 9/11.

To the Office of the Prosecutor of the International Criminal Court

- Continue to monitor whether US authorities pursue credible and impartial criminal investigations and prosecutions of detainee abuse allegedly committed by members of the US armed forces in Afghanistan between 2003 and 2008.
- Consider opening a formal investigation into US-related abuses in Afghanistan if no criminal proceedings take place in the US and other relevant criteria are met to establish jurisdiction.

Acknowledgments

The first three chapters of the report on the lack of accountability in the US, were written by Laura Pitter, senior national security counsel at Human Right Watch. The fourth chapter, International Accountability Mechanisms, was written by Leslie Haskell, former counsel in the International Justice Program at Human Rights Watch.

The entire report was reviewed and substantively edited by James Ross, legal and policy director. Joseph Saunders, deputy Program director, provided further edits.

The first three chapters were reviewed and edited by Maria McFarland, US Program co-director. Andrea Prasow, deputy Washington director, and John Sifton, Asia advocacy director, provided specialist review and further edits. Alison Parker, US Program co-director, also provided limited edits to the report. Julia Liston, Human Rights Watch summer Klatsky Fellow, provided assistance with legal research, as did interns, Adam Kirchner, Morgan Moone, and Charles Church. W. Paul Smith, US Program coordinator also assisted with legal research but primarily contributed research on non-legal issues. Human Rights Watch is enormously grateful to the many journalists, human rights reporters, and non-governmental organizations committed to reporting about these abuses and who have made enormous contributions to the record on CIA abuses that now exists. In particular we would like to thank the American Civil Liberties Union for its Freedom of Information Act litigation that has led to the declassification of many important documents related to CIA abuses and torture. We would also like to thank the many other non-governmental organizations, government entities, and academic institutions that have worked on documenting abuses and advocating for accountability, including Amnesty International and Amnesty International USA, the ACLU, The Constitution Project, Openthegovernment.org, The Open Society Justice Initiative, Human Rights First, the Center for Victims of Torture, the National Religious Campaign Against Torture, Physicians for Human Rights, The New York Center for Human Rights and Global Justice, and the International Human Rights Clinic at Harvard Law School. We would also like to thank the American Bar Association for publicly urging the Department of Justice to open new investigations into CIA torture and other ill-treatment.

The section on International Accountability Mechanisms was edited by Elise Keppler, International Justice Program associate director. Benjamin Ward, Europe and Central Asia Division deputy director, Judith Sunderland, Europe and Central Asia Division associate director, and Géraldine Mattioli-Zeltner, International Justice Program advocacy director provided specialist review. Aurelie Poelhekke, International Justice Program associate, and Hamish Collings-Begg, intern in the International Justice Program provided research and editorial assistance. Valuable research assistance was also provided by Andreas Schüller, legal advisor in the International Crimes and Accountability Program of the European Center for Constitutional and Human Rights (ECCHR); Jürgen Schurr and Kyra Hild, legal advisors at Redress; Steve Kostas, lawyer with the Open Society Justice Initiative, who spoke in his personal capacity; and Dr. Sam Raphael, co-director of The Rendition Project and senior lecturer in international relations at Kingston University.

W. Paul Smith, US Program coordinator and Maya Goldman, US Program associate jointly copy edited the entire report. Kathy Mills, publications specialist and Jose Martinez provided production assistance.

NO MORE EXCUSES

A Roadmap to Justice for CIA Torture

Following the attacks on the United States on September 11, 2001, the US Central Intelligence Agency (CIA) operated a global, state-sanctioned program in which it abducted scores of people throughout the world, held them in secret detention—sometimes for years—or “rendered” them to various countries, and tortured or otherwise ill-treated them.

Many detainees were held by the CIA in pitch-dark windowless cells, chained to walls, naked or diapered, for weeks or months at a time. The CIA forced them into painful stress positions that made it impossible to lie down or sleep for days, to the point where many hallucinated or begged to be killed to end their misery. To date, no one has been held accountable for these abuses that amount to crimes under US and international law.

No More Excuses: A Roadmap to Justice for CIA Torture provides a path forward. The report sets out a detailed analysis of the various criminal charges available and challenges claims put forward by the US Justice Department that prosecutions for torture are not legally possible. It also outlines steps the US should take to provide compensation and rehabilitation to victims of torture; and steps other countries should take to pursue their own criminal investigations into CIA torture.

Human Rights Watch calls on the United States to appoint a special prosecutor to conduct a thorough, credible criminal investigation of those who authorized and implemented the CIA program as well as those who committed acts of torture beyond what was purportedly authorized. The US should also acknowledge wrongdoing, apologize, and provide redress to victims of torture.

Cover illustration © 2015 Brian Stauffer for Human Rights Watch